

HIGH TEMP. VALVES



PRODUCT CATALOGUE





PERFORMING IN DEMANDING APPLICATIONS

Ball Valves & Actuators for the most demanding, challenging and hazardous applications is our passion and profession for the last 70 years. We believe in designing, manufacturing and supplying control and shutoff components and solutions that improves the overall safety, integrity and sustainability of the systems they are installed in.

Designed, manufactured and tested according to the highest standards, our products allow us to partner within systems that flows and control varied gases and liquids in divers markets especially where extreme temperatures and pressures are involved, hazardous materials are used and system performances are critical.

We are leading in cryogenic ball valve-based control solutions, emergency shutoff ,High Pressure and Severe Service and specially designed solutions. Believing that supplying and developing the most effective, safe and reliable products for the global leaders in the Gas distribution Severe Service and BioTech markets continually challenges us to improve our capabilities and products. Best coping with our prestigious customers' most challenging requirements technically, operationally and commercially is the outcome and our contribution to the development of these high end markets.

Table of contents

About Habonim	6
Habonim Valves	11
High Temperature Valves	37



HOW TO USE THIS CATALOGUE

This catalogue provides information in a hierarchical structure starting from Habonim company general information, product families, product lines, product series and to a single product data.

When using information of any level, the aggregate information of the levels above would apply and should be taken into consideration where applicable.

Online Version

A live and up-to-date electronic version of this catalog is available for online use and download on Habonim: www.habonim.com



In the case of discrepancies between the print and electronic versions, we recommend to use the latest version (the version date is printed on the back cover).

Proprietary Note

This catalog is the exclusive property of Habonim Industrial Valves and Actuators Ltd. Any unauthorized reproduction of this catalog, in whole or in part, shall be prosecuted.

Disclaimer

The products and datasheets in this catalog reflect current Habonim standard production specifications. Habonim Industrial Valves and Actuators Ltd. Reserves the right to modify products and materials, including modifications undertaken to comply with specific customer requests and technical specifications without further notice.

It is always the system designer and the end-user responsibility to verify all equipment use in their system is properly selected to ensure safety and integrity of their systems. Habonim offers only general information based on common market knowledge and standard market adaptations for its valves. For each system and use, the system designer and end-user must consider the particular operations conditions, media parameters and any other implication of their system for the proper selection of valves to be used on their solely responsibility.

PRODUCT FAMILIES

Temperature	
°C	°F



ACCESSORIES



ACTUATORS

650	1200
600	1100
550	1000
500	900
450	800
400	750
350	650
300	550
250	480
200	390
150	300
100	200
50	120
0	32
-50	-58
-100	-148
-160	-260
-185	-300
-196	-321
-269	-450

HIGH TEMP.

SANITARY

INDUSTRIAL

CONTROL

HIGH PRESSURE

CRYOGENIC

SPECIAL USE

ASME Class			150		300		600	900	1500		2500		6000	
Pressure Bar	-1	0	16	20	40	50	100	150	200	250	350	420	700	1034
Pressure Psi	-14	0	230	290	580	750	1500	2250	3000	3750	5000	6000	10000	15000

ABOUT HABONIM

Sustainability, Safety and Health

Habonim management and employees around the world are dedicated to promoting, in every aspect of their work, the following principles and guidelines:

Sustainability

Habonim management pledges to comply with the relevant laws, standards, and regulations to preserve the environment and promote sustainability at company premises and in our products.

Safety & Health

Habonim aspires to a safe and healthy work environment, aiming for zero work accidents and promoting our employee's wellbeing. Management and the entire workforce comply with the relevant laws and regulations necessary to achieve this goal.

Operations

Habonim operates a global infrastructure to best support customers and projects by supplying our catalog standard products, specially adjusted catalog products and custom-made products and sub-systems. Ball valves, actuators and control packages are our core deliveries.

Standard Delivery

With the goal of offering our high-end products as well as our general-use products with best availability, best quality, cost-effectiveness and with simple communication, handling and operation, we mark selected items designated as **Standard Offer** in most of our product lines with the Green "Standard Delivery" mark in order to provide best availability and supply readiness.





Materials

Habonim uses and stocks metallic, polymeric and other materials used in our products, all sourced from well-recognized manufacturers with the required testing, certifications and documentation.

Heat numbers and materials certificates are managed throughout the manufacturing and assembling process to enable full backtracking for our product components.

Available Certifications, some supply as standard and some per request:

- Materials certificates per EN10204 type 2.2/3.1/3.2
- FDA / USP Class VI compliant for polymers, elastomers, and lubricants where applicable
- CE1935:2004 compliant for polymers, elastomers, and lubricants where applicable

Tagging, Traceability

Each product is tagged for traceability. For product identification, a stainless steel nameplate is placed on the product body.

Traceability of assembly and testing procedures, heat codes, and foundry identification as per B16.34 stipulations where applicable.



ABOUT HABONIM

Cleaning, Assembling and Packing

Habonim manages different levels of cleaning, assembling and packing lines to meet different levels of end product and use requirements:

Commercial Service

Excessive hydrocarbon films, water, rust or mill scale, shop dirt, filings, chips or loose weld spatter is removed from the valve parts.

- Accessible surfaces are inspected for cleanliness by the naked eye under bright white light.
- Inaccessible surfaces are inspected and cleaned indirectly by wiping.
- A sticker on the package indicates the cleaning grade of the product.

Oxygen

A meticulous cleaning and assembly procedure eliminate the ignition hazards that can be caused by the presence of hydrocarbon oil, grease, and metal chips.

Our process of cleaning, assembling and packing refers to international standards in partial or in full:

- ASTM A380 • CGA G 4.1 • EN 12300

Habonim uses an environment friendly, alkaline-based degreasing process with controlled parameters. Valves are assembled in an oil-free restricted area by personnel who are specially equipped and trained to perform this task. The assembling area, work surfaces, equipment and tools are specially maintained to ensure cleanliness requirements are met.

- Valves are capped ends and plastic bagged
- A sticker on the plastic bag indicating "oxygen use"





Quality

Habonim strives to deliver quality products that meet and exceed customer expectations, providing complete and total satisfaction and to operate, instruct and train employees globally in light of standards such as:

- ISO 9001:2015
- CE PED 2014/68/EU (Module H)
- ATEX 2014/34/EU
- API SPEC Q1: 2013
- TPED 2010/35/EU and TPE - CDG 2009 – for specific product lines
- IEC 61508-2:2010 (SIL 2 / 3) – for specific product lines
- SIL IEC 61508-1,2, 2010/35/ EU – for specific product lines

Habonim’s management diligently monitors goals and objectives and continually enhances processes and products as well as the safety and environmental practices in light of the above.

Testing and Laboratories

Habonim operates a wide range of testing laboratories and equipment for ongoing and R&D needs and certifies products for cryogenic, high pressure, aggressive or clean, industrial use and more.

Habonim carries out external and internal testing and certification of products per customers’ requests and market trends on a regular basis and offer a wide range of certified products for diverse certification bodies as but not limited to:

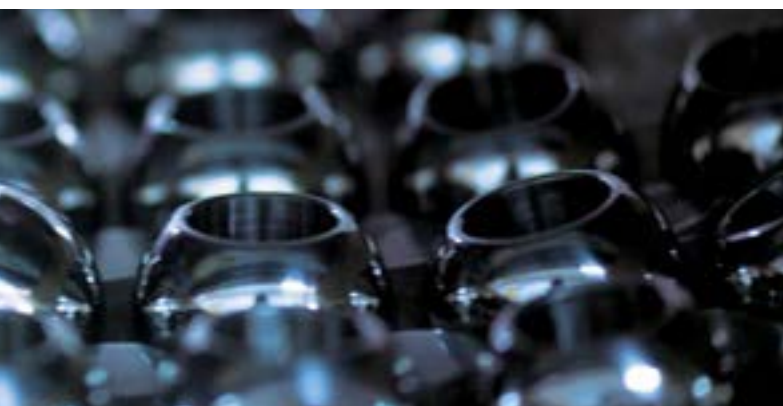

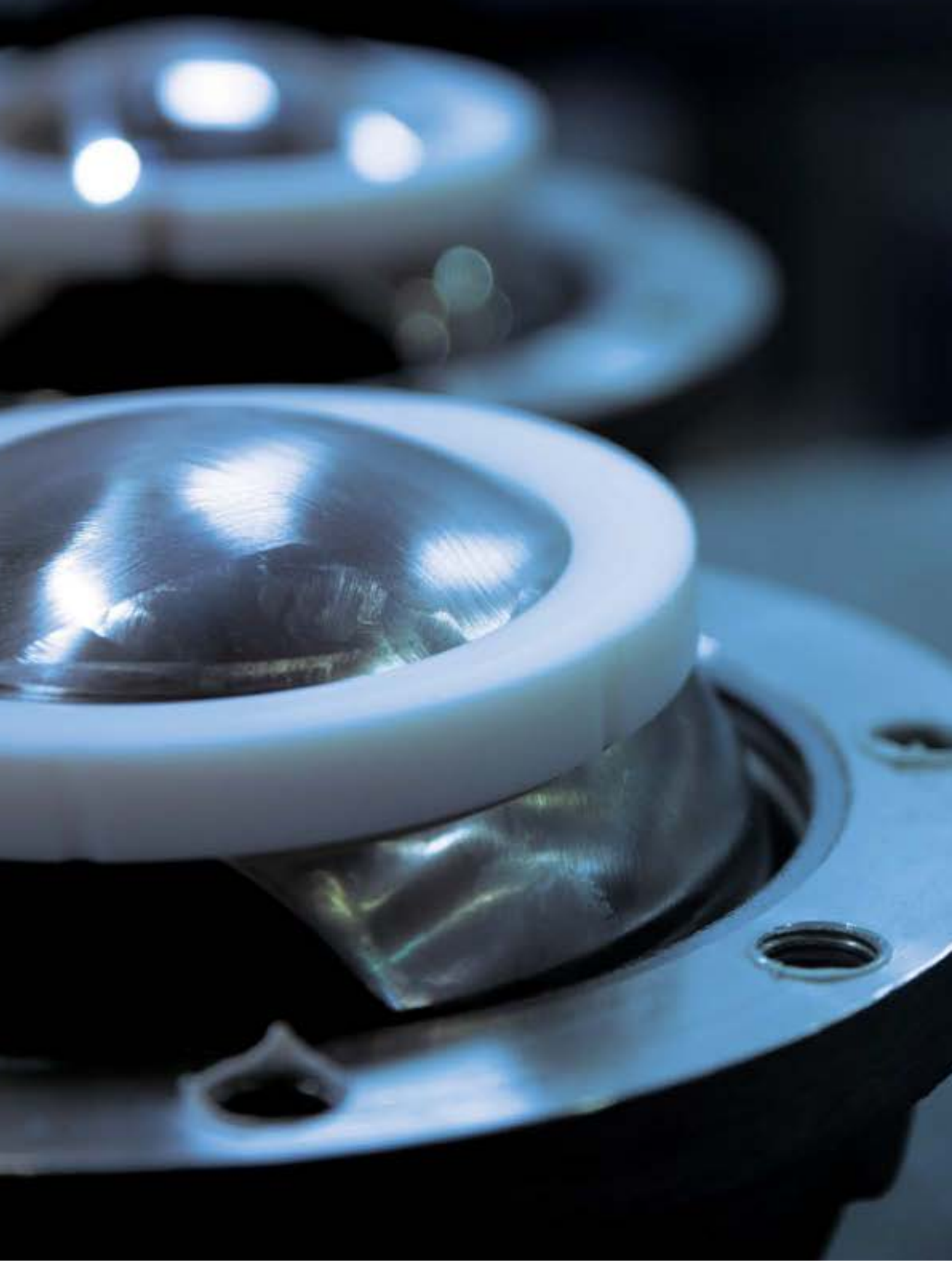



VALVES

Habonim Ball Valves	12
Valve Features	22
High Temperature	37

HABONIM BALL VALVES

General

Habonim develops, designs, manufactures, tests, supplies and service ball valves for the global market and is globally leading in some segments of ball valve usage. With high-end products, uncompromised quality, serviceability and innovation to create solutions for the most demanding applications Habonim has gained a long track record of proven success. Habonim's ball valve product line supports extreme cold to extreme heat systems, industrial use up to very high pressures, and meets the specific needs and regulations of a wide range of industries.



Habonim ball valve product lines are subject to the company's regulation, methodologies and certification – for more information, see Habonim introduction chapter.

Design and Engineering

Habonim designs its valves with accordance to international standards and guidelines in full, partial or with reference to. For some an external certification is available:

- API 6D (number 6D-1278)
- ASME VIII Div I
- API608
- ASME B16.34
- ISO 14313
- ISO 17292
- ASME BPE (48SER)
- ISO 15848-1, API641
- Fire safe design per API 607, ISO 10497, API6FA
- Antistatic design per ISO 17292

For relevant valves, Habonim complies or use as guidelines market leading standards such as, but not limited to:

- NACE MR-0175
- NDT/DT (according to ASME B16.34)
- MSS SP-55
- Polymers per TSE/BSE, BAM, FDA, USP, CE1935:2004





Testing

Habonim refers to the following international standards for valve testing:

- API 598
- ISO 15848-2
- API6D
- EN 12266-1/2
- ISO 5208

Strength/Valve shell leak test:

- Tested per quality system procedures
- By usage of compressed air, nitrogen or water

In-Line Leak Test:

- 100% of valves are tested
- By compressed air, nitrogen or helium
- At 5-7 bar pressure
- Pass criteria:
 - Rate A result (bubble tight shutoff) for soft seated valves

Functional Test:

- 100% of valves are tested
- Torque is tested to design limits

Packing

Habonim valves are delivered as a standard as:

- Valve in open position
- Actuated valves are delivered in fail-safe position
- Ends are capped
- A firm, clean package packed by soft, clean, shock-absorbing material for transportation protection.



HABONIM BALL VALVES



Registered EU Design
015025978-0001

As a standard, most of HABONIM valves are equipped with the Total HermetiX integrity package comprised of three main elements and a superior inline sealing mechanisms in some of them:

Zero fugitive-emission no maintenance stem sealing

- Patented HermetiX® stem sealing design with zero fugitive emission sealing capability.
- Tested or certified according to ISO 15848-1 and API641 standards.
- Up to 500,000 cycles of operation.
- Field proven for millions of cycles continuous operation.

Double body sealing

- Body-to-ends & body-to-bonnet double sealing for superior sealing.
- Selection of sealing materials for diverse applications.
- Fugitive emission prevention.

Fire-safe

- According to API 607 & ISO 10497 - where applicable.
- Type-tested and certified by leading certification bodies for marine service – for some valve series.
- Clean fire-safe construction guarantees no graphite contamination of the media flow.

Superior In-line sealing

A variety of implemented mechanisms provide extended in-line sealing capabilities such as:

- Bidirectional sealing
- High pressure full Δp sealing
- High & low pressure sealing
- Others

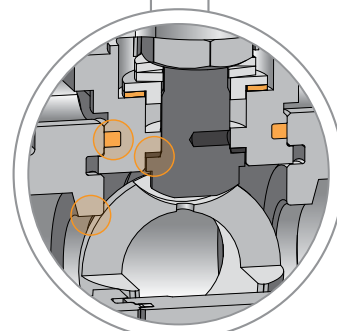
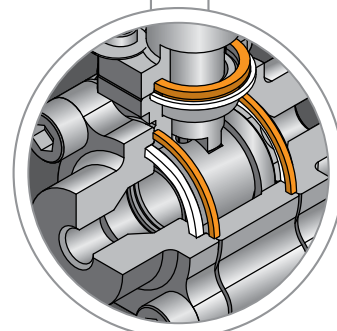
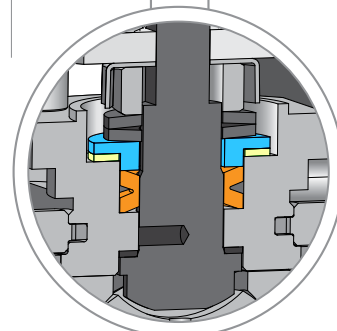



Quarter Turn Valves - Introduction

Quarter-Turn Ball Valves Design Styles

HABONIM offers ball valves in a variety of design styles and technologies that is most effectively supports a wide range of applications and use cases. We offer Floating ball style valves and Trunnion-mounted ball style valves with several construction methods.

Floating Ball Valves Design

The floating ball valve is the legacy style for ball valves, the most used and best fit for many industrial applications. The design places the valve ball between seats that holds it in place but without a firm connection to the valve body, hence, it "floats" inside the valve. Assuring a tight seal between the seats and the ball as well as the between the seats and the valve body guaranties the valve in-line sealing by a simple structure with minimal parts. As a rule of thumb, a floating ball valve should be considered as first choice wherever applicable.



Trunnion-Mounted Ball Valves

In a trunnion-mounted valve, the ball rotates only around its vertical axis while being mechanically anchored to the top and bottom of the valve body. This construction balances the torques of the rotating ball and keeps it in a lower range than with similar sized floating ball valves by tolerating the heavy loads applied to the valve trim as a result of large sizes, high pressures and dynamic temperature cycles. The seats are compressed against the ball sphere by the force of the springs and by the line pressure, providing "double block" or "double isolation" capability to the valve. Trunnion-mounted ball valves are often used for larger sizes, higher pressure ratings and dynamic temperatures.

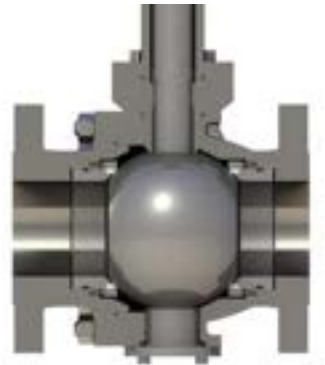

HABONIM BALL VALVES

Habonim Floating Ball Valve Designs

One-piece Design

The standard-port, one-piece, solid-cast body and flange design ensures minimum leak paths. The valve complies with ASME B16.5 for flange dimension and ASME B16.10 for Face-to-Face dimensions. The body includes an ISO 5211 integral mounting pad for easy automation. To facilitate easy assembly and maintenance, the valve is designed with one flange with a side entry that allows all inner parts to be positioned easily, and with a threaded plug that sets all parts under a precise preload with high repeatability. The result is optimum operating torque and bubble tight shut-off. It is possible to modify the ASME-standard flange connections by drilling the flanges to the EN1092 PN16 and PN40 standard. It is also possible to change one flange to a weld-end connection. A thermal jacket (steam jacket) over a one-piece design is the most efficient solution in applications where heating up the valve's outer surface (and the media inside) is mandatory to maintain media flow.

31 series | Vacuum 10^{-6} Tor; ASME B16.34 class 150 | Size ½"-8" (DN15-DN200)

32 series | Vacuum 10^{-6} Tor; ASME B16.34 class 300 | Size ½"-8" (DN15-DN200)

Two-piece Design

This unique full-port two-piece solid-cast body and flanged end design supports high flow capacity. The Habonim two-piece design is available in ASME B16.10 for Face-to-Face dimensions and ASME B16.5 class 150 and ASME class 300 flange dimensions and also in EN 1092 PN16 and PN40. The body includes an ISO 5211 integral mounting pad for easy automation. The valve is designed as a split construction which facilitates easy assembly and maintenance with standard tools. Tightening the end connector to the valve body via the body bolts preloads the complete ball-seat set, ensuring low operating valve torque, repeatability, and bubble tight shut off.

73 series | Vacuum 10^{-6} Tor; ASME B16.34 class 150 | Size ½"-8" (DN15-DN200)

74 series | Vacuum 10^{-6} Tor; ASME B16.34 class 300 | Size ½"-8" (DN15-DN200)

77 series | Vacuum 10^{-6} Tor; EN 1092 flanged PN16 | Size 3"-6" (DN80-DN150)

78 series | Vacuum 10^{-6} Tor; EN 1092 flanged PN40 | Size ½"-2½" (DN15-DN65)



Three-piece Design

The forged, cast, or rolled bar 3-piece design is comprised of a body (center section) and a variety of end connectors (thread, weld, flange) to facilitate a wide range of construction configurations. The swing-out design of the center section allows the end connector to remain a fixed part of the pipe work while the valve itself can be maintained by swinging out the center section only.

- 26 series** | Full port, solid cast | Vacuum 10^{-6} Tor
| In full compliance with ASME B16.34 class 600 | Size 2"-8" (DN50-DN200)
- 27 series** | Standard and full port, forged or rolled bar | Vacuum 10^{-6} Tor
| ASME B16.34 class 2500 (wall thickness) | Size ¼"-2" (DN8-DN50)
| ASME B16.34 class 1500 (wall thickness) | Size 2½"-8" (DN65-DN200)
| Hybrid seats technology as an option
- 28 series** | Standard & full port, forged or rolled bar, robust design, with Hybrid seats technology | Vacuum 10^{-6} Tor
| ASME B16.34 class 2500 (wall thickness) | Size ¼"-8" (DN8-DN200)
- 47 series** | Standard or full port design, forged, cast or rolled bar | Vacuum 10^{-6} Tor
| ASME B16.34 class 900 (wall thickness) | Size ¼"-2" (DN8-DN50)
| ASME B16.34 class 600 (wall thickness) | Size 2½" (DN65)
| ASME B16.34 class 400 (wall thickness) | Size 3"-6" (DN80-DN150)
- 48 series** | ASME BPE Floating Ball 3 Piece | Tube-size design, forged, cast or rolled bar
| Vacuum 10^{-6} Tor
| ASME B16.34 class 300 | Size ½"-1½" (DN15- DN40) | ASME B16.34 class 300
| Size 2"-6" (DN50- DN150)

Three-piece Threaded-Body Design

The forged, cast, or rolled bar 3-piece threaded-body design is comprised of a body (center section) and a variety of end connectors (thread, Coned & Threaded) to facilitate a wide range of construction configurations. The no-bolts design of the valve is suitable for high and very-high pressures.

- 24 series** | Standard and full port, Floating ball design, forged or rolled bar
| Vacuum 10^{-6} Tor | In full compliance with ASME B16.34 class 2,500
| Size ¼"-1½" (DN8-DN40)
- 25 series** | Forged or rolled bar | Floating ball design | Vacuum 10^{-6} Tor
| In full compliance with ASME B16.34 for 550 bar (8,000psi)
| Size ¼"-1½" (DN8-DN40)
- 29 series** | Forged or rolled bar | Floating ball design | Vacuum 10^{-6} Tor
| In full compliance with ASME B16.34 for 1,034bar (15,000psi)
| Size ¼"-1½" (DN8-DN40)



HABONIM BALL VALVES

Habonim Floating Ball Valve Designs

Multiport valves

Multiport valves are primarily used to simplify pipe and valve systems by replacing multiple two-way valves with a single multiport valve. They minimize dead legs, optimize drainability, simplify system validation and have a reduced envelope profile for easier installation. Multiport valves allow piping and machine engineers to design a simpler system that saves space and has fewer flow elements and leak paths. One multiport valve can replace multiple two-way valves and automation devices, and provides safe and easy changeover and flow shutoff, all within a confined space. Reducing the quantity of piping and fittings also means faster and more cost-effective construction. Available in a variety of flow patterns and directions and in both automatic and manual configurations, the design possibilities offered by the multiport valve are virtually unlimited.

- 61 series** | Multiport with three horizontal ports
| Standard or full port design, forged or cast
| Vacuum 10^{-6} Tor
| ASME B16.34 class 600 (wall thickness) | Size ¼"-1½" (DN8-DN40)
| ASME B16.34 class 300 | Size 2"-4" (DN50-DN100)

- 62 series** | Multiport with four horizontal ports
| Standard or full port design, forged or cast
| Vacuum 10^{-6} Tor
| ASME B16.34 class 600 (wall thickness) | Size ¼"-1½" (DN8-DN40)
| ASME B16.34 class 300 | Size 2"-4" (DN50-DN100)



Diverter valves

Diverter valves are primarily used to split or combine process flows, or to switch medium among different pieces of process equipment such as pumps, filters, or whole pipelines. Diverter valves provide reliable high flow rates in the most severe operating conditions, including vacuum conditions. They can also handle highly viscous media without the need for constant back-flushing. The diverter valves are available with different ball designs to accommodate a wide range of flow patterns. These flexible flow combinations reduce the number of valves in a system, thereby saving costs and facilitating easier control. Because all of the diverter valves have the same body Face-to-Face dimensions, they can be used with all standard end connections.

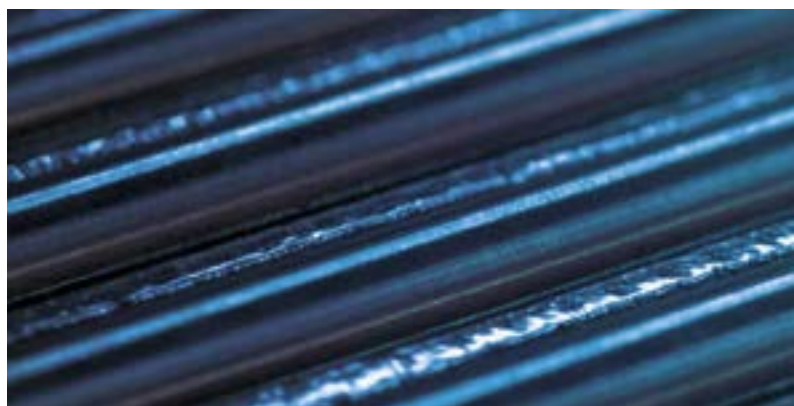



- D31 series** | Bottom entry diverter
| Standard port design, cast | Vacuum 10^{-6} Tor
| ASME B16.34 class 150 (wall thickness) | Size ½"-8" (DN15-DN200)
- S31 series** | Side entry diverter
| Standard port design, cast | Vacuum 10^{-6} Tor
| ASME B16.34 class 150 (wall thickness) | Size ½"-8" (DN15-DN200)
- D32 series** | Bottom entry diverter
| Standard port design, cast | Vacuum 10^{-6} Tor
| ASME B16.34 class 300 (wall thickness) | Size ½"-8" (DN15-DN200)
- S32 series** | Side entry diverter
| Standard port design, cast | Vacuum 10^{-6} Tor
| ASME B16.34 class 300 (wall thickness) | Size ½"-8" (DN15-DN200)
- D47 series** | Bottom entry diverter
| Standard or full port design, forged or cast | Vacuum 10^{-6} Tor
| ASME B16.34 class 600 (wall thickness) | Size ¼"-2½" (DN8-DN65)
| ASME B16.34 class 300 (wall thickness) | Size 3"-6" (DN80-DN150)
- S47 series** | Side entry diverter
| Standard or full port design, forged or cast | Vacuum 10^{-6} Tor
| ASME B16.34 class 600 (wall thickness) | Size ½"-2½" (DN15-DN65)
| ASME B16.34 class 300 (wall thickness) | Size 3"-6" (DN80-DN150)
- D61 series** | Multiport with three horizontal ports
| Additional bottom port available
| Standard or full port design, forged or cast
| Vacuum 10^{-6} Tor
| ASME B16.34 class 600 (wall thickness) | Size -1" (DN8-DN40)
| ASME B16.34 class 300 | Size 2"-4" (DN50-DN100)
- D62 series** | Multiport with four horizontal ports
| Additional bottom port available
| Standard or full port design, forged or cast
| Vacuum 10^{-6} Tor
| ASME B16.34 class 600 (wall thickness) | Size -1" (DN8-DN40)
| ASME B16.34 class 300 | Size 2"-4" (DN50-DN100)

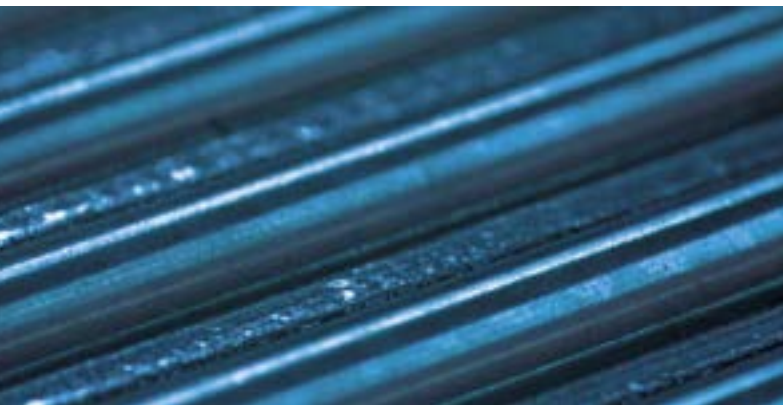

HABONIM BALL VALVES

Habonim Trunnion-Mounted Ball Valve Designs

Features:

- Specially designed to endure the harsh conditions of the oil & gas, petrochemical and other demanding applications
- Underground, above ground, offshore and onshore installation
- Full differential pressure (Δp) per the valve pressure rating
- Manually applies a maximum operating force of 360N (80 lbf)
- Double block & bleed single valve capability
- Seats preloaded by helical springs
- Antistatic grounding between ball, stem & body as standard
- Bi-directional flow
- Double Piston Effect (DPE) and Single Piston Effect (SPE) designs are both available
- Optional additions for 8" valve size and above:
 - Injection fittings for emergency stem or seat sealant & lubrication maintenance
 - Equipped with lifting lugs
 - Manually operated via gearbox
- Buttweld end valves may be supplied with extended spool pieces (PUPS) to avoid any risk of seat and seal damage during welding and post weld heat treatment operations

External finishing:

- Austenitic stainless steel valves are delivered in their natural finish
- Carbon steel valves are sandblasted and externally coated with paint
- Other painting systems are available upon request

One-Piece Design

- 52 series** | Cryogenic Top Entry Trunnion Mounted
| Size 1½"-6" (DN40-DN150) | Class 300





Two-Piece Design

The 2-piece cast trunnion-mounted ball valve designs are cost effectively support pressure ratings up to ASME Class 600, serving as the first choice where applicable with ANSI flange ends.

- 81 series** | Full Port | Vacuum 10^{-6} Tor
| ASME B16.34 class 150 (wall thickness) | Size 2"-16" (DN50-DN400)
- 82 series** | Full Port | Vacuum 10^{-6} Tor
| ASME B16.34 class 300 (wall thickness) | Size 2"-16" (DN50-DN400)
- 83 series** | Full Port | Vacuum 10^{-6} Tor
| ASME B16.34 class 600 (wall thickness) | Size 2"-16" (DN50-DN400)



Three-Piece Design

The 3-piece forged body and end design is a robust heavy-duty design for pressure ratings up to ASME Class 2500 With ANSI flange, DIN flange or weald ends.

- 91 series** | Full & Standard Port | Vacuum 10^{-6} Tor
| ASME B16.34 class 150 (wall thickness) | Size 2"-16" (DN50-DN400)
- 92 series** | Full & Standard Port | Vacuum 10^{-6} Tor
| ASME B16.34 class 300 (wall thickness) | Size 2"-16" (DN50-DN400)
- 93 series** | Full & Standard Port | Vacuum 10^{-6} Tor
| ASME B16.34 class 600 (wall thickness) | Size 2"-16" (DN50-DN400)
- 94 series** | Full & Standard Port | Vacuum 10^{-6} Tor
| ASME B16.34 class 900 (wall thickness) | Size 2"-16" (DN50-DN400)
- 95 series** | Full & Standard Port | Vacuum 10^{-6} Tor
| ASME B16.34 class 1500 (wall thickness) | Size 2"-12" (DN50-DN300)
- 96 series** | Full & Standard Port | Vacuum 10^{-6} Tor
| ASME B16.34 class 2500 (wall thickness) | Size 2"-12" (DN50-DN300)



Three-Piece Threaded Body Design

- 99 series** | forged or rollrd bar | Trunnion ball design | Vacuum 10^{-6} Tor
| In full compliance with ASME B16.34 for 1,034 bar (15,000psi)
| Size ¼"-1" (DN8-DN25)



VALVE FEATURES

Fire Safe Design

Valves to be used in explosive or fire-hazard areas need to be (according to some standards and regulations) be designed to prevent in-line leaks for at least 30 minutes when exposed to flames and/or temperatures between 900 - 1000°C. In addition, after cooling down, a fire-safe valve has to be able to be cycled once and seal at an acceptable level of in-line leakage.

Habonim fire-safe valves include body seals fabricated from graphite, which is well-known as a fire-retardant material. In the event of fire, the valve's soft seats melt and the ball is pressed against a metallic fire lip on the downstream end connector thus preventing in-line leakage. The fire also burns off the stem's thrust seal, causing the stem, which has a machined chamfer at its root, to be pushed up and form a metal-to-metal seal with the valve body and prevent leakage. For stem sealing Habonim is using the patented HermetiX seal, a unique polymer-based graphite-free stem seal that, even after its polymer materials have melted, allows the stem to stay aligned and fully operable after cool-down. During normal operation, our polymer-based stem seal allows 500,000 operation cycles without maintenance, making it remarkably more durable than porous graphite seals, which have to undergo maintenance every 5,000 cycles without refurbishment. This design has been tested and certified to API 607 and ISO 10497 standards.

Tongue & Groove Body Seal Design

A 'tongue' machined on one side of the valve body and a matching 'groove' machined on the opposite side provides a perfect interlock system that precisely aligns the body and ends along the valve's center axis, thus increasing accuracy and repeatability during valve assembly and maintenance. The tongue & groove design is used most of our fire valves so that the expanded body seal is fully encapsulated and compressed in the event of a fire. The tongue & groove design forces fluid emissions to flow in a labyrinth pattern, thus ensuring zero leakage into the atmosphere.

Body Bolts

Instead of long through-way bolts and nuts, all of our 3-piece fire-safe valves use double the number of one-size-up short bolts threaded into the body. In the event of fire these bolts minimize thermal expansion and prevent external leakage.

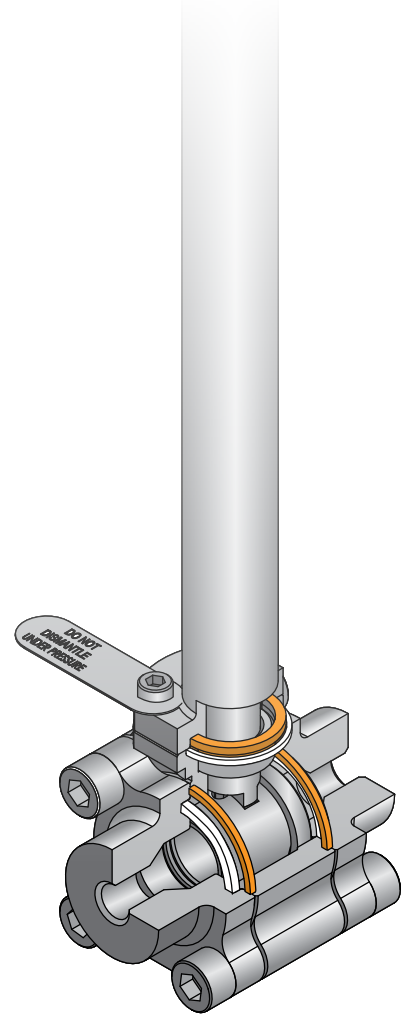



Ball Configurations

Our mirror-polished solid balls ensure tight shutoff and long service life. All balls come with specially rounded leading edges to eliminate excessive seat wear during rotation. Our balls technology can supports change to variety of metals (some are available only upon request) such as Stainless Steel 316 (CF8M), Alloy-C276, Alloy-C22, Monel 400, 254SMO, Duplex, Super Duplex, Inconel 625, Titanium and more. Ball materials other than Stainless Steel 316 (CF8M), are marked for clear identification.

There are different styles related to the ball port itself:

- Standard port ball (also known as reduced port) - The flow through the ball is one size smaller than the pipe's size resulting in a flow area smaller than the pipe's area. The reduced flow area increases the flow velocity (assuming a constant flow discharge) and the head-loss over the valve.
- Full port ball - Has an over-sized ball so that the ball's port is the same as the pipe's inner diameter, thus reducing friction loss. Flow is unrestricted but the valve is larger so full-port balls are typically used where free flow is particularly important such as in pipelines that require pigging.
- Tube size ball (also known as true port) has a port which is identical to the tube's inside diameter. This configuration is used mainly in the pharmaceutical industry where dead legs and pockets of contamination are unacceptable.

Pressure Equalizing Hole

Balls typically have a hole in the stem slot to equalize the pressure over the ball sphere. The pressure inside the ball port and the pressure in the valve cavity are identical and hence no stress is applied to the ball sphere. The pressure equalizing hole is eliminated in the following cases:

- High surface finish requirements, mechanically polished or electro-polished
- Diverter valves
- Valves with cavity filler seats
- Double block and bleed valves
- Pharmaceutical or other applications with very high sanitary requirements



Minimum stress on the ball by adding a pressure equalizing hole



VALVE FEATURES

Ball Configurations

Cavity Pressure Relief

This safety feature is for valve applications where a trapped cavity must be avoided a 3 mm hole is included in the upstream ball sphere so that any pressure that builds up in the valve cavity will be released into the upstream pipeline. The use of a cavity pressure relief hole feature is mandatory when using ammonia, chlorine or any other liquid media that is at risk of transforming into a gas and thus elevating the pressure within the valve cavity in an uncontrolled manner. A valve which includes the 'P250' code will always be unidirectional, and will include an arrow flow plate attached to the valve body. Improper installation in the opposite direction will cause an in-line leak.



3 mm relief hole
face the upstream

'C' Ball

Habonim offers a two-way ball with its upstream sphere completely machined through the ball port and thus has a C shape. This feature is mainly used where media tends to crystallize on the upstream ball sphere such as, for example, molten sugar or baked ground coffee. When a standard valve is in the closed position and a solid layer has adhered to the ball's upstream sphere, subsequent valve operation will erode the upstream soft seat, loosen the pre-load of the ball seats set, and rapidly degrade the valve's functionality. With a 'C' ball media solidification is impossible as there is no surface area on which the media can accumulate. The upstream seat withstands the media unscratched; the pre-load of the ball seat set as well as the functionality of the valve remain intact for a longer period of time.



Upstream sphere completely
machined in a 'C' ball

Multiport and Diverter Ball

Multiport and diverter ball designs are used primarily to split or combine process flows or to switch medium between alternative pieces of process equipment. The diverter ball configuration can be either bottom entry or side entry. The diverter ball has the same sphere diameter as standard 2-way balls so the same soft parts can be used. Multiport balls have numerous flow configurations, which are described in detail in the Multiport chapter of this catalog. The multiport ball has a larger sphere diameter than a diverter ball, allowing a firm grip of four seats vs. two seats in the diverter configuration.



Diverter ball with isometric
T port construction

V-Ball

The V ball is used in control valve solution for less demanding applications, such as clear liquid at a maximum pressure drop of 6 bar (87 psi), or clean gas at a maximum pressure drop of 10 bar (145 psi), and maximum temperatures of 120-°C (248-°F) for both. The V ball design is comprised of a floating characterized ball, mounted between two seats, which maintain a trim preload and bubble-tight shut-off and low torque demand. V-Balls come in a variety of 'V' and 'slot' shapes, and can be custom designed to meet any control requirement. The V-Ball is available in a wide range of high-alloy materials and coatings for highly corrosive applications.



Characterized ball for flow
control applications



Downstream Pressure Relief Ball

Habonim ball downstream pressure relief is designed with a diagonal hole in the downstream sphere toward the bottom of the ball. In the open position the flow runs smoothly through the valve. When the valve is closed the downstream pressure is vented through the diagonal tunnel and out via a third port incorporated into the valve body so that the relieved pressure can be diverted safely to a secured area. This feature is mainly used for pressure gauges and instrumentation service. This design eliminates the need to install an additional downstream pressure vent valve.

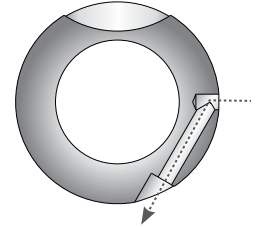

Special diagonal tunnel vents downstream pressure when the valve is closed.

CIP/SIP

Habonim 'CIP' ball code is mainly used in sanitary and biopharm applications. In clean applications the main ball valve problem is contamination caused by impurities trapped in the cavity between the ball's outer sphere and the valve body's inside diameter. To overcome this problem Habonim has designed a special ball that allows the stream to clean the valve cavity thoroughly during the CIP/SIP process, with the valve in the full open position. The bottom line: Bidirectional and streamlined flow with a high Cv, and self-cleaning of hidden cavities.

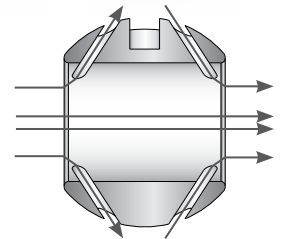

With the valve in the open position, special tunnels flush the valve cavity constantly



VALVE FEATURES

Seat Configurations

Standard Seat

A flexible, precision-machined seat that provides the highest seal capabilities (EN12567 Rate A) in high pressure and vacuum conditions. Its unique design reduces valve torque, facilitating a more compact, lower-weight automated package. The design also reduces wear, thus extending the life of the seat. The seat perimeter has pressure-equalizing slots to allow pressure to penetrate into the body cavity for better sealing and for avoiding upstream seat collapse into the valve cavity while turning the valve ball from the open to closed position under high differential pressure.



Standard seat

Self-Relieving-Seat (SRS)

The Self Relieving Seat (SRS) is used mainly in syltherm and dowtherm services in the chemical and biopharm industries. Both syltherm and dowtherm have a high thermal expansion coefficient and in trapped cavities (such as when the valve ball is in its closed position) even a moderate temperature increase will cause dramatic pressure build-up that can cause cessation of valve operation, seat swelling, and even valve shell failure. The SRS is designed to flex and allow the trapped pressure to escape into the pipeline, while shutting off as soon as the peak pressure is relieved. The pressure relief is achieved by a special internal groove that is machined into the seat radii facing the ball. Additional radial grooves enable the pressure to bypass the ball and access the internal groove. The seat sealing surface is in the central internal section and provides tight shutoff. The outer section of the seat above the internal groove gives the support needed to the ball when higher line pressure pushes the ball toward the downstream seat, thus preventing "crushing" of the seat. SRS seats can be used with a differential pressure up to ASME Class #300.



Self-Relieving-Seat (SRS)

Seat-seal

In some use cases valve must seal the pressure at the upstream side, which contradicts the traditional floating ball mode of operation (where sealing is typically done on the downstream seat only). Habonim's solid one-piece seat-seal design blocks the flow through the back of the seat, generating an upstream seal. Seat-seal can be used with differential pressure up to ASME Class300. For higher differential pressures use either a valve with hybrid seats, or a dual floating ball valve integrated into a one block or trunnion mounted valve.



Seat-seal

Hybrid Seat

When a soft seated floating ball valve is held even momentarily at mid position, the upstream seat is only partially supported by the ball and can be pushed towards the valve cavity by the force of the stream. This deformation is amplified with increased media density, high differential pressure and/or high velocity. Under these extreme conditions the deformation can: cause the ball to grip the unsupported area of the soft seat and jam the valve; slice the seat by the port edge of the ball; or trigger stem twisting (caused by excessive torque applied by the operator trying to close the valve). Habonim's line of Hybrid seats were developed especially to overcome the problems posed by high differential pressure applications. The combination of a metallic housing and polymer insert offers the stiffness of a metal seat with the bubble tight shutoff leakage rate and operating torque of a soft seat. Different hybrid seat designs were developed to meet the needs of different applications, and are designated by the metallic housing design.



Hybrid seat



Seat Configurations

Cavity filler seat

The cavity filler seat design minimizes crevices and gaps between the ball and the valve body, thus reducing the risk of trapped contaminants. Because the valve body is specially machined with a larger bore diameter to fit the special cavity filler seat dimensions, they cannot be retrofit into a standard valve body. The cavity filler seat is a one piece seat-seal design and is therefore suitable for use with the Habonim 3-piece product line.

Note: A valve with a cavity filler seat cannot be used in fire-safe service.



Cavity filler seat

Metal seat

Habonim metal seats are used for extreme service applications where high temperature, abrasion and/or corrosion restrict the use of soft seats. The metal seats are mated lapped with the ball for enhanced engagement and sealing. A variety of surface treatments and coatings can be applied to the seat's outer surface to withstand corrosion, galling and other forms of wear.



Metal seat

V-port seat

Superior control performance and accuracy is designed into the geometry of the downstream V-port. The precision wire cut 'V' shape of a metal seat, enables equal percentage flow characteristics, while S-port design ('Slot') provides linear flow characteristics. V-Port valve assembly, comprised of a ball and wire cut metal seat, lapped together into a single seamless component. V-port design provides the high rangeability and precision throttling required for clean or dirty liquids and gases, as well as fibrous suspension applications. The streamlined flow passage allows for high recovery, maximum efficiency and excellent erosion resistance.



V-port seat



VALVE FEATURES

Stem Design

A crucial component in a quarter-turn ball valve is the stem, which transfers the torque from the operator to rotate the ball and control its movement. The stem geometry and surface finish is crucial to minimize stem leak and maximize ease of operation. The stem is a dynamic element and, in most cases, is the only element that protrudes from the pressure vessel and is thus subject to safety issues as well. Habonim's robust stem design complies with ASME B16.34 and API 6D and can endure at least twice the valve's nominal torque. To solve a major safety issue, the stem is designed to be "blowout-proof". Because it is inserted into the valve body from within, the stem will not release under pressure. All Habonim stems are, by default, fire-safe design. A special chamfer is machined at the root of the stem so that, in the event of fire, the stem is pushed upwards and seals against the valve body - metal to metal engagement. Various stem materials are available, from austenitic stainless steel to nickel alloys, to titanium for light and moderate torque requirements, and for high cycle applications or high torque demands. The stem top planes for valve sizes ½" (DN15) up to 2½" (DN65) are typically a Double-D shape, while 3" (DN80) stems and above typically have a square shaft (although a Double-D stem can be provided upon request by adding the 'WR' suffix to the valve description).

Anti-Static Design

An anti-static device provides for electrical continuity between the body, ball and shaft of the valve and is used to discharge static electricity buildup on electrically isolated balls. According to the EN ISO 17292 standard, all valves with a size up to 2" (DN ≤ 50) require a stem/body contact, while larger valve sizes also require a ball/stem contact. The anti-static feature shall have electrical continuity across the discharge path with a resistance not exceeding 10 Ω from a power source not exceeding 12 VDC when type tested on a new, dry, as-built valve after pressure testing and cycling of the valve at least five times. The Habonim anti-static device, in which contact is made via a spring loaded stainless steel element, complies with EN ISO 17292 and is, in fact, built-in to all Habonim valve product lines, without exception.

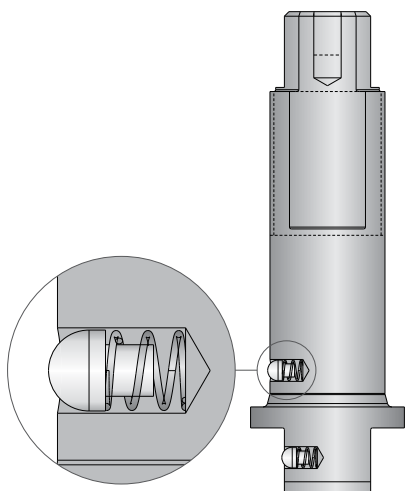

Anti-static design

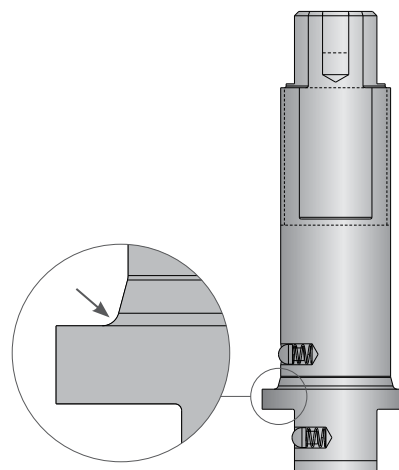

Stem design



Stem Seals

The valve trim - and the valve stem seal design in particular - determine the quality of a valve. The stem seal must perform two tasks: keep the media within the boundaries of the pressure vessel, and allow uninterrupted leak-free continuous open/closed quarter-turn rotation.

Unlike the valve body's static seal, the stem seal is subject to dynamic operation of the valve, as well as to side loads resulting from actuator misalignment or from the operator forcing the handle incorrectly. The valve trim typically comprises two Belleville springs assembled Face-to-Face, which preload the stem seal. This self-adjusting mechanism compensates for wear and pressure/temperature differentials - ensuring a leak-tight seal and extended service life. Habonim's trim design for heavy-duty service, such as high cycle applications, uses four or even six sets of Belleville springs so as to maintain preload over a longer operational cycle life. The Belleville springs are compressed by the stem nut, which is locked to prevent unintentional release during cycles.

Habonim's stem seal design, consisting of a live-loaded thrust bearing and anti-abrasion ring combined with a stem seal, significantly increases valve cycle life over conventional ball valves and extends the time between adjustments.



VALVE FEATURES

Stem Seals

Graphite-free fire safe HermetiX® stem seal

The patented HermetiX® stem seal is named for its distinctive "X"-shaped design. The flexible "X" shape creates a dynamic sealing arrangement so that, in the event of pressure buildup or side load, the HermetiX® adjusts dynamically to prevent fugitive emissions. The result is a superior stem seal design compared with the conventional flat stem seals currently available on the market.

The HermetiX® Fire-safe. This patented design includes a polymer based stem seal and a unique fire safe certified construction. The graphite-free stem seal, suitable for use in hazardous industries such as chemical, petrochemical, oil & gas, Food & Beverages is designed to operate for 500,000 cycles without refurbishment. The HermetiX® fire safe valve offers the ultimate solution - an exclusive graphite free stem seal that eliminates the risk of graphite disintegration after prolonged valve cycles, protecting both line materials and air quality. The HermetiX® fire safe valve meets the requirements of fire-safe API 607 / ISO 10497 standards, as well as the stringent ISO 15848-1 standard.

Features

- Prevents media contamination from graphite particles
- FDA, CE1935:2004 approved polymer or other materials is available upon request
- Fugitive emission certified to ISO 15848-1 and API 641
- Habonim patented design
- Designed to operate for 500,000 cycles without refurbishment
- Prevents media contamination from graphite particles
- Ensures uninterrupted production
- Increases site safety
- Anti-static as standard



No pressure Pressure build-up Side load

Slide bearing
Thrust seal
HermetiX® stem seal

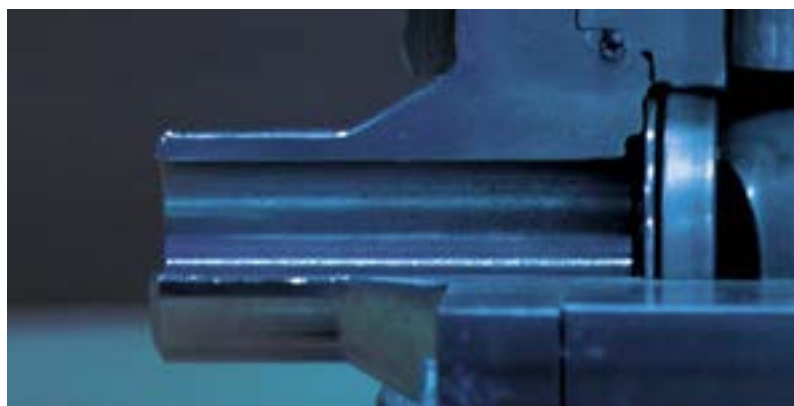
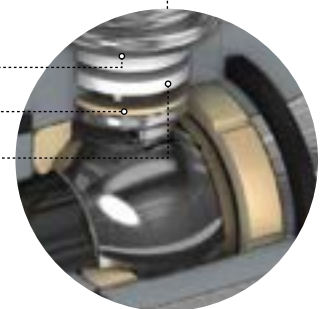



High Cycle (HC) Stem seal

High cycle service is defined by Habonim engineering as continuous operation for more than one hour at a frequency greater than 1 cycle / 180 seconds.

When designing a valve for high cycle service parameters, such as heat dissipation due to friction of metallic and plastic parts, resistance to fatigue stress, and mean time between maintenance activities must be taken into consideration.

For high cycle applications Habonim recommends the use of valve stems made of high tensile material. The stem will be polished for a high degree of surface roughness. The stem thrust seal will always be made from highly wear-resistant plastic material. A Viton O-ring is inserted into a customized follower. The complete trim assembly is preloaded by a double or even triple Belleville spring stack. All of these design features give the valve a particularly long service life.

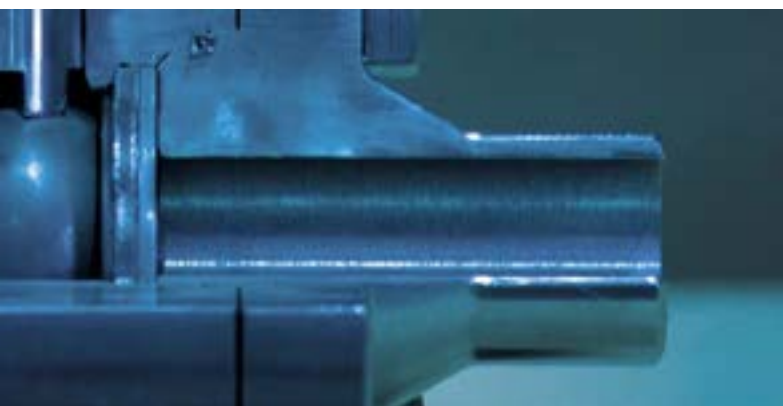
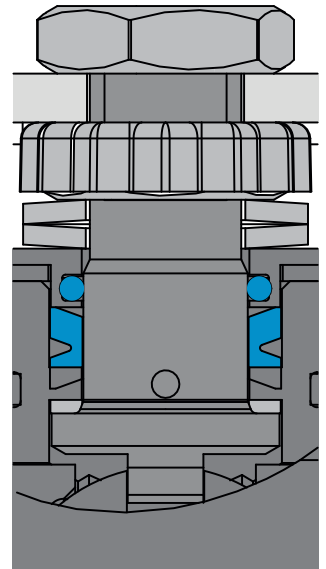

VALVE FEATURES

End Connections

Habonim offers a variety of end connections for its 3-piece valves, supporting the industry standard connections for piping in diverse applications and geographies.



TC/TCI/TCD

Tri-Clamp end - designed to ASME BPE (TC) standard, allows fast connection or removal of the valve from the line. Mainly used in the pharmaceutical and food & beverage industries.

BW

Buttweld end for various pipe schedule - designed to ASME B16.25, EN12627-4, BW code stands for buttweld schedule 40, for different pipe schedule BW should be followed by the relevant schedule number (5,10,80,160)



SW

Socket-weld end one piece solid cast designed to ASME B16.11 and EN 12760. Leaving a 1 mm gap (average) between the pipe end and the socket inner plan is a common welding practice to avoid internal stress due to thermal expansion during the welding process



XBW

Extended buttweld end for various pipe schedule - one piece solid cast - special design for in-line welding save labor cost and keep the integrity of the product factory tested.



XSW

Extended Socket-weld end one piece solid cast - special design for in-line welding save labor cost and keep the integrity of the product 'factory tested'



BWO / BWI / BWD

Buttweld end for various tube standards - designed to ASME BPE (BWO), ISO 1127 (BWI) and DIN 11850 (BWD). The length of this end doesn't allow the use of orbital welding.



ETO / ETI / ETD

Extended buttweld end for various tube standards - designed to ASME BPE (ETO), ISO 1127 (ETI) and DIN 11850 (ETD). One piece solid cast with sufficient length to allow the use of orbital welding. Habonim ETD end connections are designed in accordance to EN10357 – Series A.

Habonim ETI end connections are designed in accordance to EN10357 – Series C.

Dimensions of the end-connections tube ends are suitable to be welded on tubes that meet this standard.

For other tube sized ends please contact a Habonim representative.



Standard	Sizes	Wall thickness (mm)	End Connection (19-22)	End Connection Length
ISO 1127	3/8"-3/4"	1.6	BW1.6	Short
			ET1.6	Extended
	1"-2 1/2"	2.0	BW2.0	Short
			ET2.0	Extended
	Over 2 1/2"	2.3	BW2.3	Short
			ET2.3	Extended



CTM

Coned and Threaded type female connection to be used with Coned & Threaded medium-pressure tubing and connection components.

Female connection geometry and sizes per the Below.

Size	Dimensions - mm (inches)					
	A	B	C	D	F	H
02	9.9(25/64)	7/16-20	7.1(.28)	12.7(.28)	4.8(.19)	2.8(.109)
03	13.1(33/64)	9/16-18	9.6(.38)	9.6(.38)	7.9(.31)	5.2(.203)
06	19.1(3/4)	13/16-16	11.1(.44)	11.1(.44)	12.7(.50)	9.1(.359)
07	32.9(1.19/64)	3/4-14	12.7(.50)	12.7(.50)	16 (.63)	11.1(.438)
10	45.47(1.79)	13/8-12	20.6(.81)	20.6(.81)	22.4(.88)	14.3(.562)

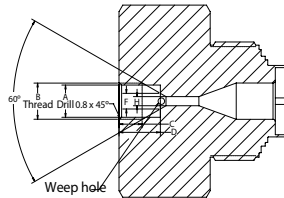

NPT / BSPT / DIN2999 / DIN3852

Female thread end designed to ASME B1.20.1 NPT EN 10226-1 BSPT/DIN2999/DIN3852 and more



MNPT / MBSPT

Male thread end designed to ASME B1.20.1 NPT EN 10226-1 BSPT/DIN2999/DIN3852 and more



LL / LM

Compression ends for metric (code LM followed by the tube OD in mm) or imperial (code LL) tube dimensions. mainly used in instrumentation services, with sizes up to 1" (DN25)



Grayloc®

Grayloc® compatible hub designed to fit an opposite hub for an easy low or high pressure connection Using a self-energized seal (Grayloc® is a registered trademark of Grayloc Products, L.L.C.)



Flanged			
150	ASME B16.5 #150 RF	PN16	EN1092 PN16 RF
300	ASME B16.5 #300 RF	PN40	EN1092 PN40 RF
600	ASME B16.5 #600 RF	PN63	EN1092 PN63 RF
900	ASME B16.5 #900 RF	PN100	EN1092 PN100 RF
		PN160	EN1092 PN160 RF



150/300/600/900 | PN16/40/63/100/160

Raised Face flange ends designed to ASME B16.5 or EN1092 for a variety of pressure classes.

Valve Face To Face sizes are per Habonim catalog data only.

VALVE FEATURES

Handles

A valve handle is the interface between the operator's hand and the valve trim. Habonim's handles are designed for safe operation, with a firm and comfortable grip. To facilitate ease of operation, the handle length ensures that the maximum force required at the handle-end to apply the breakaway torque will never exceed 360 N (80 lbf). The handles are manufactured in a variety of technologies: casting, forging, punching, and laser cut and welding. The standard materials are zinc plated carbon steel and stainless steel. Habonim's range of handle designs addresses the diverse needs of multiple applications.

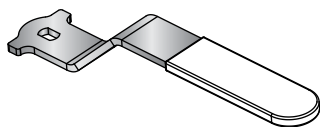

The 'SHARK' handle

Habonim's standard handle for valves with an ISO 5211 top pad.

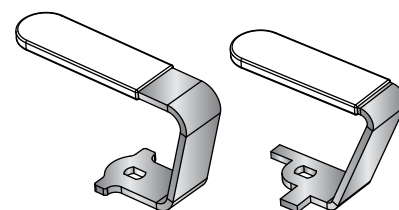

The 'SCORPION' handle

Habonim's special handle for confined spaces. There are two types to accommodate valves with or without an ISO 5211 top pad. To specify a valve with the SCORPION handle add the '-SCRIP' suffix to the valve code.

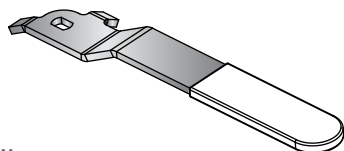

The 'POINTER' handle

Habonim's standard handle for valves without an ISO5211 top pad.

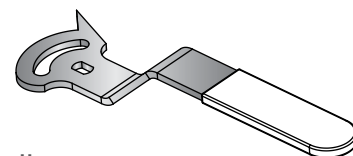

The 'ADJUSTABLE' handle

Habonim's special handle for manually controlled valves. It is supplied as part of a kit that includes a lock-in-place mechanism and a mirror-polished scale for clear identification of the valve's angular position. To specify a valve with the ADJUSTABLE handle add the '-ADJ' suffix to the valve code.



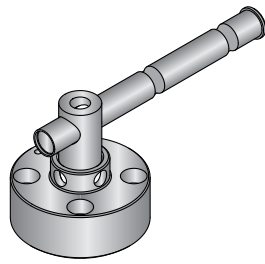

The T-Handle (TH)

Habonim's special handle designed for trailers with its compact footprint and lockable option. Available in the following Habonim high-pressure TPED certified series: 24, H24, H25 and H29.

The rod can be moved from side to side to increase leverage for a better user interface experience.

To specify a valve with the T-Handle, add the '-TH' suffix to the valve code.



The Oval handle (OVL)

Habonim's special handle designed to avoid unintentional movement of the valve handle. It is also used in confined spaces where the handle must not protrude beyond the valve's Face-to-Face plate. To specify a valve with the OVAL handle add the '-OVL' suffix to the valve code.

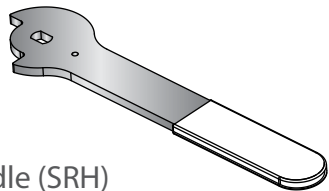

The Spring Return Handle (SRH)

An extra thick handle design to withstand the severe impact during valve closing. This handle is part of the SRH unit.

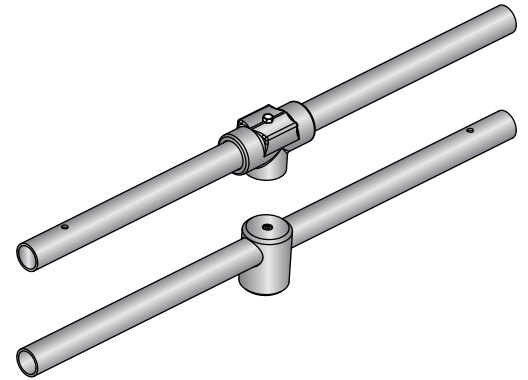

Habonim's standard handle for large valves (2½" and above)

Habonim's standard handle for large (2½" and above) cryogenic, high pressure and metal-seated valves, and for large (3" and above) standard valves. It provides a firm grip and smooth operation. The maximum force required at the handle-end to apply the breakaway torque shall not exceed 360 N (80 lbf). Habonim supplies valves with 2½" standard port and above for manual operation with handles attached to or packed with the valve. (with the exemption of 47 series which is for 3" standard port and above). If the valve is to be automatically actuated, Habonim removes the handle and prepares the valve stem seal accordingly. To specify a valve prepared for automated actuation, add the '-BS' (bare shaft) suffix to the valve code. The '-BS' suffix does not apply to valves size up to and including 2.







HIGH TEMP. VALVES

General 38

Trunnion

3 Piece 43

2 Piece 61

Floating Ball

3 Piece 75

High Pressure | 3 Piece 93

HIGH TEMP. VALVES

General

 Habonim's High Temp. product line valves are subject to the general Habonim valves design, materials, practices, methodologies and certifications – for more information, see Valves General chapter.

 Habonim Control valves are equipped (in some series) with the Total HermetiX integrity package for superior sealing, safety and environmental care.

High Temperature - Metal Seated Ball Valve

Habonim's extended line of High Temperature - metal seated valves perform and excels in the harshest industrial environments, where valve durability is critical to ensure safety, minimize failures and promote efficiency. These meticulously engineered metal seated ball valves are designed to withstand the harshest applications and process conditions, including extreme high temperature, high pressure and abrasive medium.

Careful metallurgical selection of all valve parts, special surface treatments including hard coatings, thorough analyses of mechanical strength and thermal expansion and vast experience of successful installations ensure that Habonim High temperature – metal seated valve line is the best choice for industry's toughest applications.

Seat Design

Description	Bi-directional shutoff, encapsulated spring loaded seat	Shutoff class	BS-EN 12266-1 Rate C, FCI 70-2 Class VI (Factory tested)
Temperature	-60°C +650°C (-76°F + 1200°F)	Service	Pulp & paper, slurries, catalyst

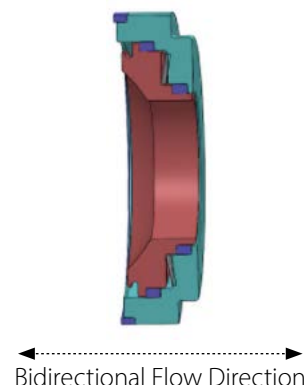

Metal Selection and Surface Treatments

HVOF (High Velocity Oxygen Fuel):

Various HVOF spray solutions based on chromium and tungsten carbides. Is used for applications up to 650°C (1200°F).

ASME B16.34 listed forged bar materials:

Even for the higher temperature range up to 650°C (1200°F) Habonim uses ASME B16.34 listed forged bar material for the construction of the valve pressure-containing elements.

Stellite welding:

For severe abrasive conditions such as pulp and paper processing, Habonim uses a minimum of 1.5 mm thick, hard stellite coating. These coatings are specifically engineered to meet the customer's application to provide outstanding resistance to abrasion and corrosion for a lifetime of effective operation in harsh applications.

Lapping:

Each ball and seat sub-assembly is accurately machined, ground and then mate-lapped for a perfect match. The complete valve assembly demonstrates high repeatability in terms of sealing (Rate B - factory tested), low torque and smooth operation at various temperatures and pressures.



Quick Selection Table

Total HermetiX® | Port: Standard Port Full Port Tube Size | End Connections: Threaded Flanged Welded
 Ordering Code

		Temperature range -40°C (-40°F) up to:			Valve Size (Inches)																						
Ball Valve Style	Design Type	Ordering Code	Series	260°C (500°F)	450°C (752°F)	650°C (1200°F)	TH	Port	End Con.	1/4	3/8	1/2	3/4	1	1 1/4	1 1/2	2	2 1/2	3	4	6	8	10	12			
										MWP (ANSI Class / DIN PN)																	
Trunnion Mounted Ball	3 Piece	<input type="checkbox"/>	Z91	W	Z	Q	<input type="checkbox"/>	<input type="radio"/>	<input type="radio"/>	<input type="checkbox"/>	<input type="checkbox"/>	<input type="checkbox"/>	<input type="checkbox"/>	<input type="checkbox"/>	<input type="checkbox"/>	<input type="checkbox"/>	<input type="checkbox"/>	<input type="checkbox"/>	<input type="checkbox"/>	<input type="checkbox"/>	<input type="checkbox"/>	<input type="checkbox"/>	<input type="checkbox"/>	<input type="checkbox"/>	<input type="checkbox"/>	150	
		<input type="checkbox"/>	Z92					<input type="radio"/>	<input type="radio"/>	<input type="checkbox"/>	<input type="checkbox"/>	<input type="checkbox"/>	<input type="checkbox"/>	<input type="checkbox"/>	<input type="checkbox"/>	<input type="checkbox"/>	<input type="checkbox"/>	<input type="checkbox"/>	<input type="checkbox"/>	<input type="checkbox"/>	<input type="checkbox"/>	<input type="checkbox"/>	<input type="checkbox"/>	<input type="checkbox"/>	<input type="checkbox"/>	<input type="checkbox"/>	300
		<input type="checkbox"/>	Z93					<input type="radio"/>	<input type="radio"/>	<input type="checkbox"/>	<input type="checkbox"/>	<input type="checkbox"/>	<input type="checkbox"/>	<input type="checkbox"/>	<input type="checkbox"/>	<input type="checkbox"/>	<input type="checkbox"/>	<input type="checkbox"/>	<input type="checkbox"/>	<input type="checkbox"/>	<input type="checkbox"/>	<input type="checkbox"/>	<input type="checkbox"/>	<input type="checkbox"/>	<input type="checkbox"/>	<input type="checkbox"/>	600
		<input type="checkbox"/>	Z94					<input type="radio"/>	<input type="radio"/>	<input type="checkbox"/>	<input type="checkbox"/>	<input type="checkbox"/>	<input type="checkbox"/>	<input type="checkbox"/>	<input type="checkbox"/>	<input type="checkbox"/>	<input type="checkbox"/>	<input type="checkbox"/>	<input type="checkbox"/>	<input type="checkbox"/>	<input type="checkbox"/>	<input type="checkbox"/>	<input type="checkbox"/>	<input type="checkbox"/>	<input type="checkbox"/>	<input type="checkbox"/>	900
		<input type="checkbox"/>	Z95					<input type="radio"/>	<input type="radio"/>	<input type="checkbox"/>	<input type="checkbox"/>	<input type="checkbox"/>	<input type="checkbox"/>	<input type="checkbox"/>	<input type="checkbox"/>	<input type="checkbox"/>	<input type="checkbox"/>	<input type="checkbox"/>	<input type="checkbox"/>	<input type="checkbox"/>	<input type="checkbox"/>	<input type="checkbox"/>	<input type="checkbox"/>	<input type="checkbox"/>	<input type="checkbox"/>	<input type="checkbox"/>	1500
		<input type="checkbox"/>	Z96					<input type="radio"/>	<input type="radio"/>	<input type="checkbox"/>	<input type="checkbox"/>	<input type="checkbox"/>	<input type="checkbox"/>	<input type="checkbox"/>	<input type="checkbox"/>	<input type="checkbox"/>	<input type="checkbox"/>	<input type="checkbox"/>	<input type="checkbox"/>	<input type="checkbox"/>	<input type="checkbox"/>	<input type="checkbox"/>	<input type="checkbox"/>	<input type="checkbox"/>	<input type="checkbox"/>	<input type="checkbox"/>	2500
Trunnion Mounted Ball	2 Piece	<input type="checkbox"/>	Z81		Z	Q	<input type="checkbox"/>	<input type="radio"/>	<input type="checkbox"/>	<input type="checkbox"/>	<input type="checkbox"/>	<input type="checkbox"/>	<input type="checkbox"/>	<input type="checkbox"/>	<input type="checkbox"/>	<input type="checkbox"/>	<input type="checkbox"/>	<input type="checkbox"/>	<input type="checkbox"/>	<input type="checkbox"/>	<input type="checkbox"/>	<input type="checkbox"/>	<input type="checkbox"/>	<input type="checkbox"/>	<input type="checkbox"/>	150	
		<input type="checkbox"/>	Z82					<input type="radio"/>	<input type="radio"/>	<input type="checkbox"/>	<input type="checkbox"/>	<input type="checkbox"/>	<input type="checkbox"/>	<input type="checkbox"/>	<input type="checkbox"/>	<input type="checkbox"/>	<input type="checkbox"/>	<input type="checkbox"/>	<input type="checkbox"/>	<input type="checkbox"/>	<input type="checkbox"/>	<input type="checkbox"/>	<input type="checkbox"/>	<input type="checkbox"/>	<input type="checkbox"/>	300	
		<input type="checkbox"/>	Z83					<input type="radio"/>	<input type="radio"/>	<input type="checkbox"/>	<input type="checkbox"/>	<input type="checkbox"/>	<input type="checkbox"/>	<input type="checkbox"/>	<input type="checkbox"/>	<input type="checkbox"/>	<input type="checkbox"/>	<input type="checkbox"/>	<input type="checkbox"/>	<input type="checkbox"/>	<input type="checkbox"/>	<input type="checkbox"/>	<input type="checkbox"/>	<input type="checkbox"/>	<input type="checkbox"/>	600	
Floating Ball	3 Pcs.	<input type="checkbox"/>	Z47	W	Z	Q	<input checked="" type="checkbox"/>	<input type="radio"/>	<input type="radio"/>	<input type="checkbox"/>	<input type="checkbox"/>	<input type="checkbox"/>	<input type="checkbox"/>	<input type="checkbox"/>	<input type="checkbox"/>	<input type="checkbox"/>	<input type="checkbox"/>	<input type="checkbox"/>	<input type="checkbox"/>	<input type="checkbox"/>	<input type="checkbox"/>	<input type="checkbox"/>	<input type="checkbox"/>	<input type="checkbox"/>	<input type="checkbox"/>	600	
		<input type="checkbox"/>	Z28	W	Z	Q	<input checked="" type="checkbox"/>	<input type="radio"/>	<input type="radio"/>	<input type="checkbox"/>	<input type="checkbox"/>	<input type="checkbox"/>	<input type="checkbox"/>	<input type="checkbox"/>	<input type="checkbox"/>	<input type="checkbox"/>	<input type="checkbox"/>	<input type="checkbox"/>	<input type="checkbox"/>	<input type="checkbox"/>	<input type="checkbox"/>	<input type="checkbox"/>	<input type="checkbox"/>	<input type="checkbox"/>	<input type="checkbox"/>	2500	
		<input type="checkbox"/>	Z47					<input type="radio"/>	<input type="radio"/>	<input type="checkbox"/>	<input type="checkbox"/>	<input type="checkbox"/>	<input type="checkbox"/>	<input type="checkbox"/>	<input type="checkbox"/>	<input type="checkbox"/>	<input type="checkbox"/>	<input type="checkbox"/>	<input type="checkbox"/>	<input type="checkbox"/>	<input type="checkbox"/>	<input type="checkbox"/>	<input type="checkbox"/>	<input type="checkbox"/>	<input type="checkbox"/>	<input type="checkbox"/>	600
		<input type="checkbox"/>	Z28					<input type="radio"/>	<input type="radio"/>	<input type="checkbox"/>	<input type="checkbox"/>	<input type="checkbox"/>	<input type="checkbox"/>	<input type="checkbox"/>	<input type="checkbox"/>	<input type="checkbox"/>	<input type="checkbox"/>	<input type="checkbox"/>	<input type="checkbox"/>	<input type="checkbox"/>	<input type="checkbox"/>	<input type="checkbox"/>	<input type="checkbox"/>	<input type="checkbox"/>	<input type="checkbox"/>	<input type="checkbox"/>	2500

ASME Class	150		300		600		900		1500		2500		6000	
Pressure Bar	0	16	20	50	100	150	250	414	1034					
Pressure psi	0	230	290	725	1450	2175	3600	6000	15000					

High Temperature – Metal Seated Designs:

Design Code	Working Temperature range	Remarks
W	-40°C to 260°C (-40°F to 500°F)	Trunnion valves only -46°C to 200°C (-50°F to 400°F)
Z	-60°C to 450°C (-76°F to 842°F)	Trunnion valves only -46°C to 327°C (-50°F to 620°F)
Q	-60°C to 650°C (-76°F to 1200°F)	Trunnion valves only -60°C to 538°C (-76°F to 1000°F)

Maximal Working Pressure Per Class / Temperature

Temperature vs Pressure (bar) - Standard class rating

ASME B16.34	Material	Temperature (°C)										
		-29 to 38	50	100	200	300	400	450	500	538	600	650
Class 150	316/316L	19.0	18.3	16.1	13.6	10.2	6.6	4.6	2.8	1.4		
	CF8M/CF3M	19.0	18.4	16.2	13.7	10.2	6.5	4.6	2.8	1.4		
	WCB/A105/LF2	19.6	19.2	17.7	13.8	10.2	6.5	4.6	2.8	1.4		
	F22	19.8	19.5	17.7	13.8	10.2	6.5	4.6	2.8	1.4	1.4	1.4
	321/321H	19.0	18.6	17.0	13.8	10.2	6.5	4.6	2.8	1.4	1.4	1.4
Class 300	316/316L	49.7	48.1	42.3	35.8	31.6	29.3	29.0	28.2	25.2		
	CF8M/CF3M	49.6	48.1	42.2	35.7	31.6	29.4	28.8	28.2	25.2		
	WCB/A105/LF2	51.1	50.1	46.6	43.8	39.8	34.7	23.0	11.8	5.9		
	F22	51.7	51.7	51.5	48.6	42.9	36.5	33.7	28.2	18.4	6.9	2.8
	321/321H	49.6	48.6	44.2	38.3	34.1	31.6	30.8	28.2	25.2	20.3	12.6
Class 600	316/316L	99.3	96.3	84.5	71.2	63.1	59.0	57.7	56.5	50.0		
	CF8M/CF3M	99.3	96.2	84.4	71.3	63.2	58.9	57.7	56.5	50.0		
	WCB/A105/LF2	102.1	100.2	93.2	87.6	79.6	69.4	46.0	23.5	11.8		
	F22	103.4	103.4	103.0	97.2	85.7	73.3	67.7	56.5	36.9	13.8	5.7
	321/321H	99.3	97.1	88.5	76.6	68.3	63.2	61.7	56.5	50.0	40.5	25.3
Class 900	316/316L	149.0	144.4	126.8	106.9	95.0	88.3	86.7	84.7	75.2		
	A105/LF2	153.2	150.4	139.8	131.4	119.5	104.2	69.0	35.3	17.7		
	F22	155.1	155.1	154.6	145.8	128.6	109.8	101.4	84.7	55.3	20.7	8.5
	321/321H	148.9	145.7	132.7	114.9	102.4	94.8	92.5	84.7	75.2	60.8	37.9
	316/316L	248.3	240.7	211.0	178.5	158.1	147.2	144.3	140.9	125.5		
Class 1500	A105/LF2	255.3	250.6	223.0	219.0	199.1	173.6	115.0	58.8	29.5		
	F22	258.6	258.6	257.6	243.4	214.4	183.1	169.0	140.9	92.2	34.4	14.2
	321/321H	248.2	242.8	221.2	191.5	170.7	157.9	154.2	140.9	125.5	101.3	63.2
	316/316L	413.8	401.0	351.7	297.2	263.6	245.5	240.4	235.0	208.9		
	A105/LF2	425.5	417.7	388.3	365.0	331.8	289.3	191.7	97.9	49.2		
Class 2500	F22	430.9	430.9	429.4	405.4	357.1	304.9	281.8	235.0	153.7	57.4	23.6
	321/321H	413.7	404.6	368.7	319.1	284.6	263.2	256.9	235.0	208.9	168.9	105.4

Temperature vs Pressure (Psi) - Standard class rating

ASME B16.34	Material	Temperature (°F)										
		-20 to 100	122	212	392	572	752	842	932	1000	1112	1200
Class 150	316/316L	275	266	233	197	148	95	67	41	20		
	CF8M/CF3M	276	267	235	199	148	94	67	41	20		
	WCB/A105/LF2	284	278	257	200	148	94	67	41	20		
	F22	287	283	257	200	148	94	67	41	20	20	20
	321/321H	276	270	247	200	148	94	67	41	20	20	20
Class 300	316/316L	720	698	613	519	458	425	420	409	365		
	CF8M/CF3M	719	697	612	518	458	426	418	409	365		
	WCB/A105/LF2	741	726	676	635	577	503	334	171	86		
	F22	750	750	747	705	622	529	489	409	267	100	41
	321/321H	719	705	641	555	494	458	447	409	365	294	183
Class 600	316/316L	1440	1396	1225	1032	915	855	837	819	725		
	CF8M/CF3M	1440	1395	1224	1034	916	854	837	819	725		
	WCB/A105/LF2	1480	1453	1351	1270	1154	1006	667	341	171		
	F22	1499	1499	1494	1409	1243	1063	982	819	535	200	83
	321/321H	1440	1408	1283	1111	990	916	895	819	725	587	367
Class 900	316/316L	2160	2094	1838	1550	1377	1280	1257	1228	1090		
	A105/LF2	2221	2181	2027	1905	1733	1511	1001	512	257		
	F22	2249	2249	2242	2114	1865	1592	1470	1228	802	300	123
	321/321H	2159	2113	1924	1666	1485	1375	1341	1228	1090	882	550
	316/316L	3600	3490	3059	2588	2293	2135	2093	2043	1820		
Class 1500	A105/LF2	3702	3634	3234	3176	2887	2517	1668	853	428		
	F22	3750	3750	3735	3529	3109	2655	2451	2043	1337	499	206
	321/321H	3599	3521	3207	2777	2475	2290	2236	2043	1820	1469	916
	316/316L	6000	5815	5100	4310	3822	3560	3486	3408	3029		
	A105/LF2	6170	6057	5630	5293	4811	4195	2780	1420	713		
Class 2500	F22	6248	6248	6226	5878	5178	4421	4086	3408	2229	832	342
	321/321H	5999	5867	5346	4627	4127	3816	3725	3408	3029	2449	1528

* It is totally forbidden to use a material when pressure rating is missing

* A105, WCB and LF2 materials are not recommended for prolonged use above 425 °C/800 °F

* F22 316L material is not recommended for prolonged use above 595 °C/1100 °F

* 316L and CF3M materials are not to be used above 455 °C/850 °F

HIGH TEMP. VALVES



Coatings

Surface coating applies on outer layer of the ball and seats. The following types of surface coating methods are available in the Habonim metal seated series: chromium carbide with nickel chrome binder (Cr₃C₂), tungsten carbide with cobalt binder (WC-Co), and stellite welding.

Cr₃C₂ (Chromium Carbide)

Chromium carbide with a nickel chrome binder is applied by a High Velocity Oxygen Fuel (HVOF) creating a 0.3mm hard outer layer. The Cr₃C₂ coating that is applied to high strength steels, results in a micro-hardness of up to 68HRC. This coating resists cryogenic temperatures down to -196 °C / -320 °F and high temperatures up to 815 °C / 1500 °F. This multipurpose wear resistance coating is used extensively in power generation, refining and hot catalyst handling services. Its corrosive limitations are in wet sulfur or chloride environments, where sulfuric acid can form and attack the coating.

WC-Co (Tungsten Carbide)

Tungsten Carbide with a cobalt binder coating is applied by HVOF techniques similar to Cr₃C₂. The WC-Co coating is applied mainly to 400 series martensitic stainless steel to provide micro-hardness that reaches 72HRC. This coating resists cryogenic temperatures down to -196 °C / -320 °F and high temperatures up to 538 °C / 1000 °F. WC-Co is a coating that consists of a hard metal alloy based on a Tungsten Carbide + Cobalt composition.

Stellite

A cobalt-based stellite coating provides excellent mechanical wear resistance, with good corrosion resistance at temperatures up to 538 °C / 1000 °F. The stellite is applied by a Plasma Thermal Arc (PTA) method. Most stellite alloys are cobalt based with elements of chromium (Cr), carbon (C), tungsten (W) and nickel (Ni). Stellite 6 is broadly used in the pulp and paper industry, as well as in refining applications, such as catalyst handling and hydrocracker processes.

Surface Treatments/ Coatings	Process Method	Process Material	Coating Thickness	Min. Hardness	Max Temp*	Corrosion Resistance
CR ₃ C ₂	HVOF spray	Chromium, Carbon Nickel	0.3 mm	68HRC	815 °C / 1500 °F	Good
DN WC-Co 40	HVOF spray	Tungsten, Carbon Cobalt	0.3 mm	72HRC	538 °C / 1000 °F	Excellent

*All temperatures above 650 °C/1200 °F refer to the coating performance only and not to the valve design

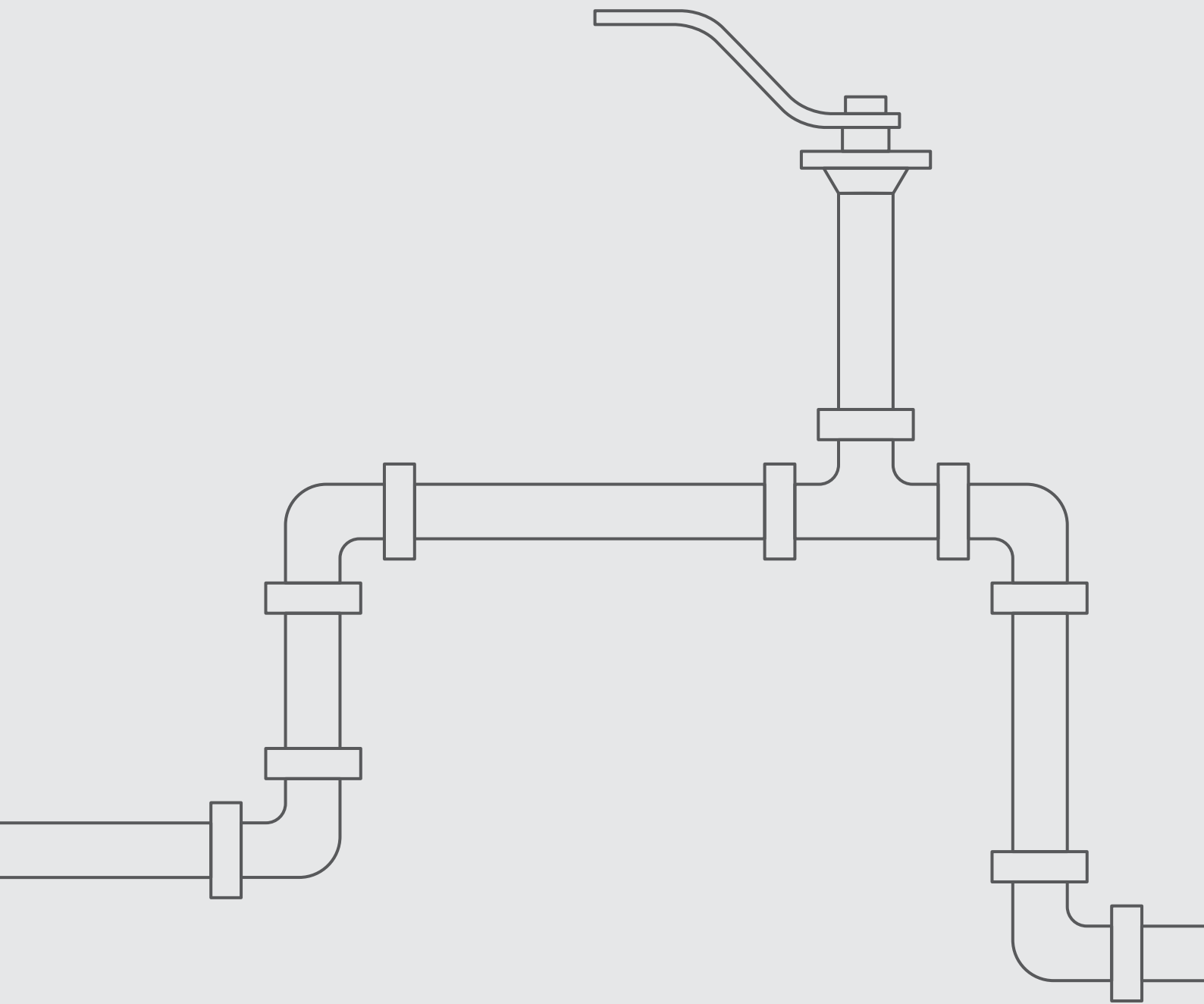

Z91

Z92

Z93

Z94

Z95

Z96



High Temp. Valves

TRUNNION

3 PIECE

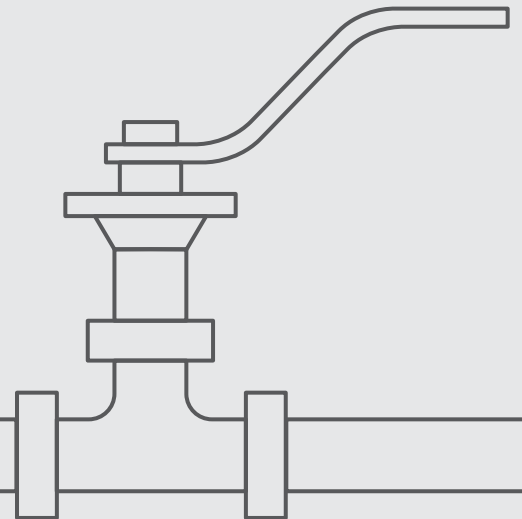

Z91W

Z92W

Z91Z

Z92Z

3"-8" | DN80-DN200
CLASS 150/300

High Temperature Trunnion Ball 3 Piece Up to

W 200°C (400°F) | **Z** 327°C (620°F)

Valve Dimensions

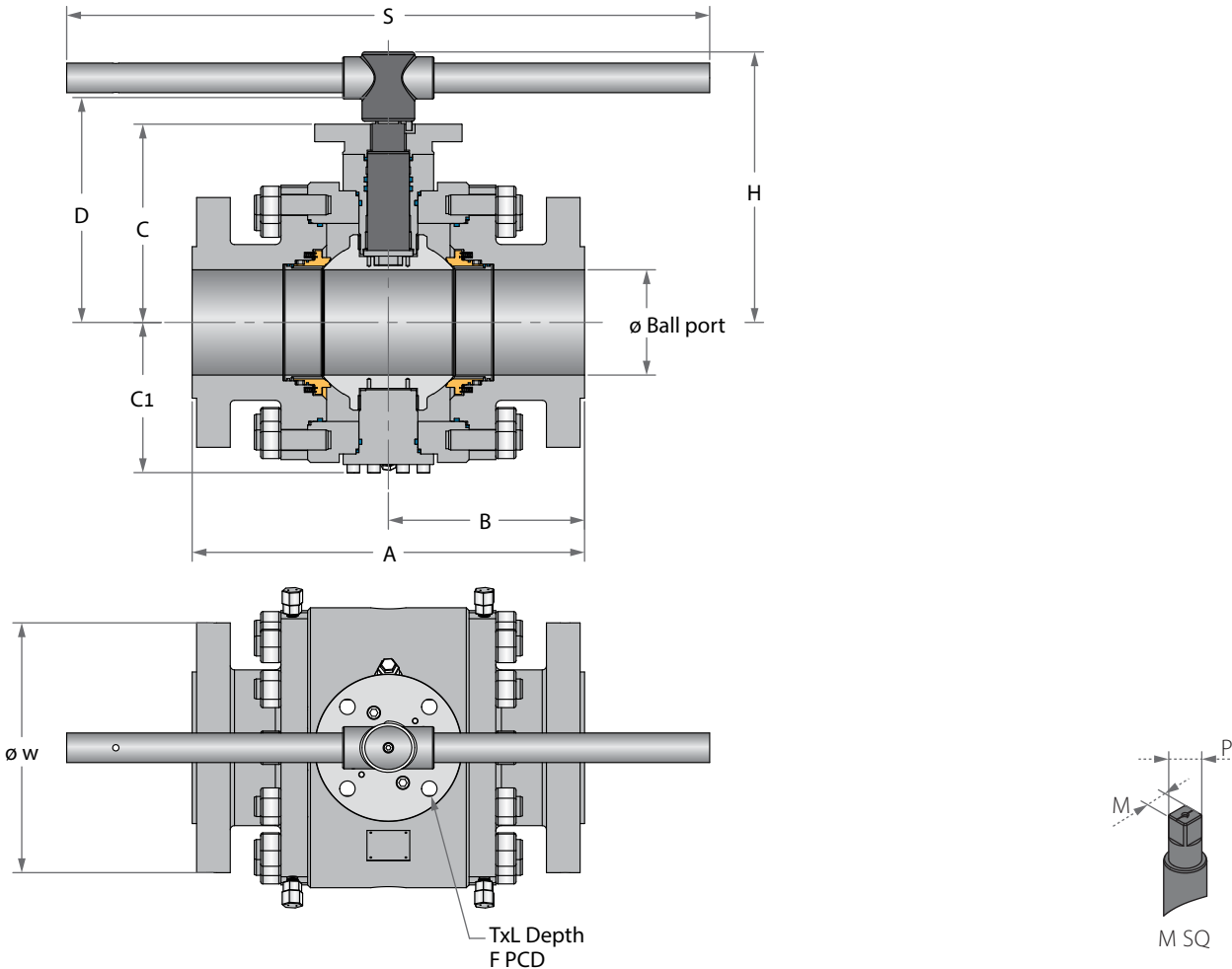

Std. port	Full port	Unit	Ball port	A		B		C	C1	D	W		M SQ	P SQ	H	S	F	TxL	Weight kg/lb		Kv/Cv		
				150	300	150	300				150	300							150	300			
DN80	DN50	mm	49.0	178.0	216.0	89.0	108.0	127.0	91.50	144.50	150.0	165.0	17.0	22.0	196.0	401.0	F10	102.0	11X15	27	31	400	363
3"	2"	inch	1.93	7.01	8.50	3.50	4.25	5.0	3.60	5.69	5.91	6.50	0.67	0.87	7.72	15.79		4.02	(4 holes)	60	68	463	420
DN100	DN80	mm	74.0	203.0	283.0	101.50	128.0	148.0	117.0	172.0	190.0	210.0	22.0	32.0	223.0	610.0	F12	125.0	13X15	44	61	1125	952
4"	3"	inch	2.91	7.99	11.14	4.0	5.04	5.83	4.61	6.77	7.48	8.27	0.87	1.26	8.78	24.02		4.92	(4 holes)	97	134	1300	1100
DN150	DN100	mm	100.0	229.0	305.0	114.50	140.50	171.0	139.0	198.50	230.0	255.0	27.0	35.0	247.50	610.0	F14	140.0	18X15	66	100	2154	1860
6"	4"	inch	3.94	9.02	12.0	4.51	5.53	6.73	5.47	7.81	9.06	10.04	1.06	1.38	9.74	24.02		5.51	(4 holes)	146	220	2490	2150
DN200	DN150	mm	150.0	394.0	403.0	185.0	230.40	254.0	191.0	290.50	280.0	320.0	36.0	46.20	356.50	916.0	F16	165.0	22X25	180	216	4723	4628
8"	6"	inch	5.91	15.51	15.87	7.28	9.07	10.0	7.52	11.44	11.02	12.60	1.42	1.82	14.04	36.06		6.50	(4 holes)	397	476	5460	5350

Z91W**Z92W****Z91Z****Z92Z**10"-12" | DN250-DN300
CLASS 150/300

High Temperature Trunnion Ball 3 Piece Up to

W 200°C (400°F) | **Z** 327°C (620°F)

Valve Dimensions

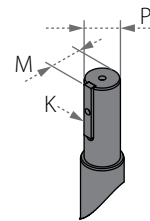
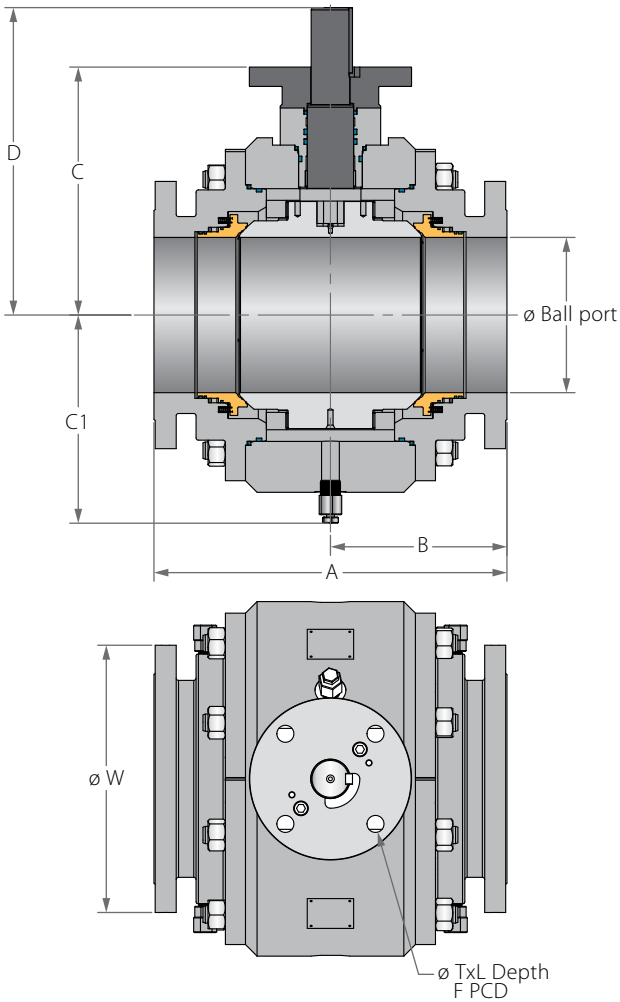

Std. port	Full port	Unit	Ball port	A		B		C	C1	D	W	P	M	K	F	TxL	Weight kg/ib		Kv/Cv		
				150	300	150	300										150	300			
DN250	DN200	mm	201.0	457.0	502.0	228.50	251.0	325.0	305.0	247.0	232.0	405.50	379.50	345.0	F16	165.0	22x25	346	378	9273	8737
10"	8"	inch	7.91	17.99	19.76	9.0	9.88	12.80	12.01	9.72	9.13	15.96	14.94	13.58		6.50	(4 holes)	763	833	10720	10100
DN300	DN250	mm	252.0	533.0	568.0	270.0	287.50	353.0	359.0	297.0	299.0	430.0	454.0	405.0	F25	254.0	18x25	473	594	15224	14792
12"	10"	inch	9.92	20.98	22.36	10.63	11.32	13.90	14.13	11.69	11.77	16.93	17.87	15.94		10.0	(8 holes)	1043	1310	17600	17100

Z93W**Z94W****Z93Z****Z94Z**3"-8" | DN80-DN200
CLASS 600/900

High Temperature Trunnion Ball 3 Piece Up to

W 200°C (400°F) | **Z** 327°C (620°F)

Valve Dimensions

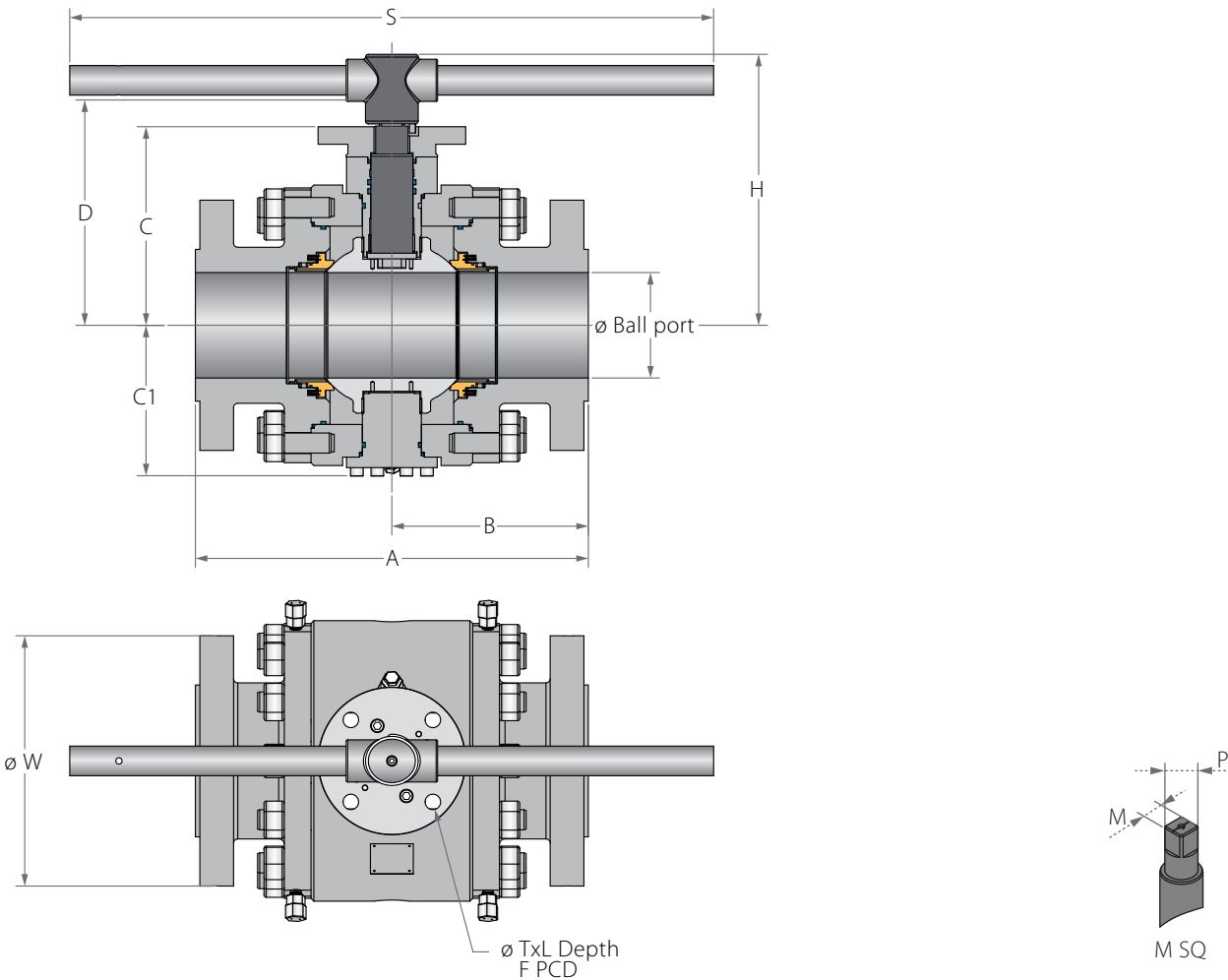

Std. port	Full port	Unit	Ball port	A		B		C		C1		D		W		M SQ	P SQ	H	S	F		TxL	Weight kg/lb				Kv/Cv	
				600	900	600	900	600	900	600	900	600	900	600	900					600	900		600	900				
DN80	DN50	mm	49.0	292.0	368.0	131.0	184.0	144.0	148.50	119.0	263.0	168.50	182.50	165.0	215.0	22.0	28.0	219.50	401.0	F12	125.0	13X15 (4 holes)	49	67	329	294		
3"	2"	inch	1.93	11.50	14.49	5.16	7.24	5.67	5.85	4.69	10.35	6.63	7.19	6.50	8.46	0.87	1.10	8.64	15.79		4.92		108	148	380	340		
DN100	DN80	mm	74.0	356.0	381.0	161.0	190.50	191.0	214.0	160.0	152.70	215.0	237.50	210.0	240.0	22.0	28.0	266.0	610.0	F14	140.0	18X24 (4 holes)	103	114	874	822		
4"	3"	inch	2.91	14.02	15.0	6.34	7.50	7.52	8.43	6.30	6.01	8.46	9.35	8.27	9.45	0.87	1.10	10.47	24.02		5.51		227	251	1010	950		
DN150	DN100	mm	100.0	432.0	457.0	216.0	228.50	217.0	193.0	184.0	184.0	246.50	259.0	275.0	290.0	27.0	36.0	316.50	916.0	F16	165.0	22X25 (4 holes)	166	186	1557	1471		
6"	4"	inch	3.94	17.01	17.99	8.50	9.0	8.54	7.60	7.24	7.24	9.70	10.20	10.83	11.42	1.06	1.42	12.46	36.06		6.50		366	410	1800	1700		
DN200	DN150	mm	150.0	559.0	610.0	278.0	305.0	282.50	368.0	214.50	224.0	320.50	463.0	355.0	380.0	36.0	48.20	385.0	916.0	F16	165.0	22X25 (4 holes)	342	418	3893	3823		
8"	6"	inch	5.91	22.01	24.02	10.94	12.01	11.12	14.49	8.44	8.82	12.62	18.23	13.98	14.96	1.42	1.90	15.16	36.06		6.50		754	922	4500	4420		

Z93W**Z94W****Z93Z****Z94Z**10"-12" | DN250-DN300
CLASS 600/900

High Temperature Trunnion Ball 3 Piece Up to

W 200°C (400°F) | **Z** 327°C (620°F)

Valve Dimensions

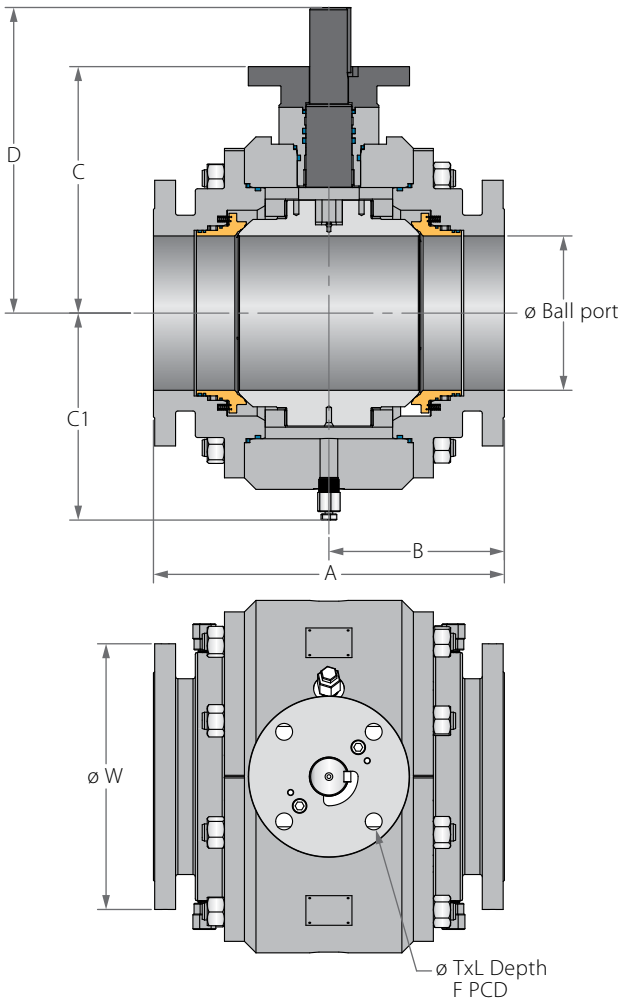

Std. port	Full port	Unit	Ball port	A		B		C		C1		D		W		P	M	K	F	TxL	Weight kg/lb		Kv/Cv		
				600	900	600	900	600	900	600	900	600	900	600	900						600	900			
DN250	DN200	mm	201.0	660.0	737.0	330.0	368.50	312.0	307.0	263.0	263.0	409.0	403.0	420.0	470.0	72.0	76.50	20.0	F25	254.0	18x25	577	836	7742	7344
10"	8"	inch	7.91	25.98	29.02	12.99	14.51	12.28	12.09	10.35	10.35	16.10	15.87	16.54	18.50	2.83	3.01	0.79		10.0	(8 holes)	1272	1843	8950	8490
DN300	DN250	mm	252.0	787.0	838.0	400.0	419.0	374.0	393.0	310.0	347.0	471.0	490.0	510.0	545.0	72.0	76.50	20.0	F25	254.0	18x25	931	1301	12543	12110
12"	10"	inch	9.92	30.98	32.99	15.75	16.50	14.72	15.47	12.20	13.66	18.54	19.29	20.08	21.46	2.83	3.01	0.79		10.0	(8 holes)	2052	2868	14500	14000

Z95W**Z96W****Z95Z****Z96Z**3"-8" | DN80-DN200
CLASS 1500/2500

High Temperature Trunnion Ball 3 Piece Up to

W 200°C (400°F) | **Z** 327°C (620°F)

Valve Dimensions

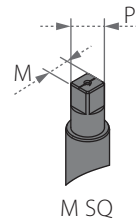
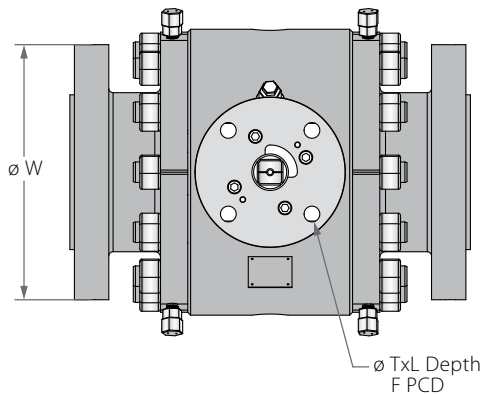
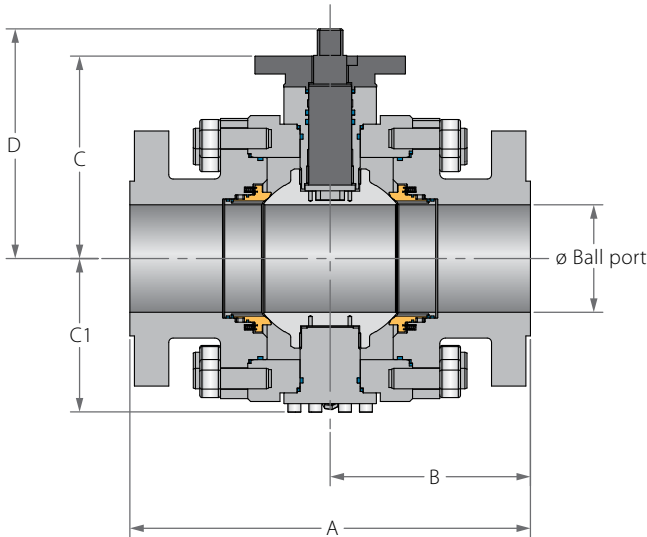

Std. port	Full port	Unit	Ball port	A		B		C	C1	D	W		M SQ	P SQ	F	TxL	Weight kg/lb		Kv/Cv		
				1500	2500	1500	2500				1500	2500									
DN80	DN50	mm	49.0	368.0	451.0	184.0	225.50	204.50	159.0	339.0	215.0	235.0	22.0	32.0	F14	140.0	18X12	90	179	281	260
3"	2"	inch	1.93	14.49	17.76	7.24	8.88	8.05	6.26	13.35	8.46	9.25	0.87	1.26		5.51	(4 holes)	198	395	325	300
DN100	DN80	mm	74.0	470.0	578.0	235.0	289.0	262.0	201.50	342.50	265.0	305.0	27.0	35.0	F14	140.0	18x22	175	340	735	649
4"	3"	inch	2.91	18.50	22.76	9.25	11.38	10.31	7.93	13.48	10.43	12.01	1.06	1.38		5.51	(4 holes)	386	750	850	750
DN150	DN100	mm	100.0	546.0	673.0	273.0	336.50	225.0	198.50	299.50	310.0	355.0	36.0	46.20	F16	165.0	22x25	330	646	1384	1228
6"	4"	inch	3.94	21.50	26.50	10.75	13.25	8.86	7.81	11.79	12.20	13.98	1.42	1.82		6.50	(4 holes)	728	1424	1600	1420
DN200	DN150	mm	150.0	705.0	914.0	352.50	457.0	310.0	272.0	425.0	395.0	485.0	46.0	59.0	F25	254.0	22x30	627	1227	3590	2206
8"	6"	inch	5.91	27.76	35.98	13.88	17.99	12.20	10.71	16.73	15.55	19.09	1.81	2.32		10.0	(8 holes)	1382	2705	4150	2550

Z95W**Z96W****Z95Z****Z96Z**10"-12" | DN250-DN300
CLASS 1500/2500

High Temperature Trunnion Ball 3 Piece Up to

W 200°C (400°F) | **Z** 327°C (620°F)

Valve Dimensions

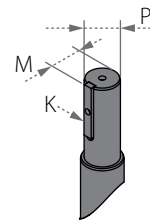
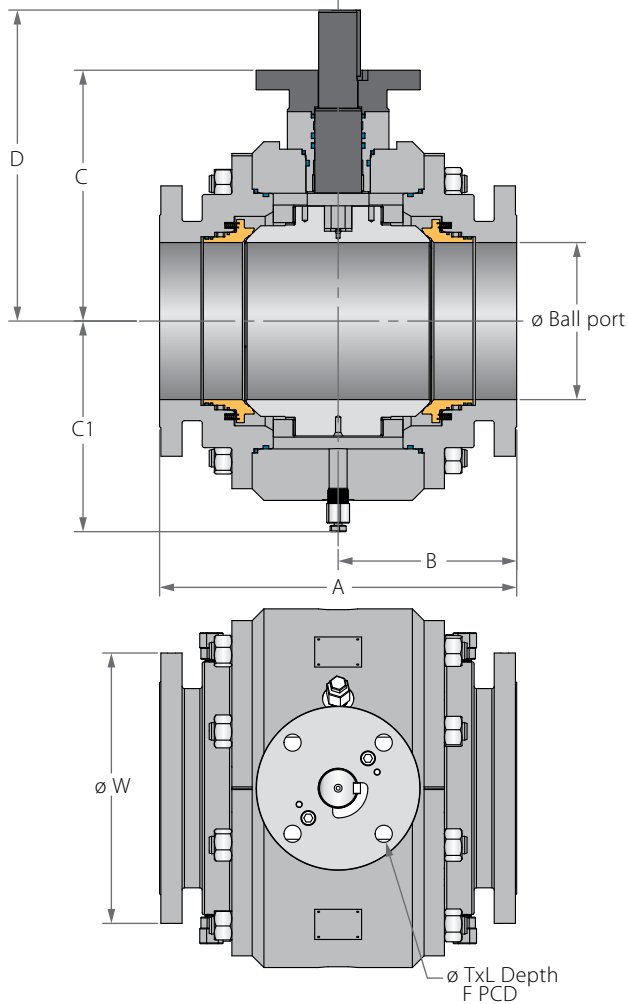

Std. port	Full port	Unit	Ball port	A		B		C	C1	D	W		P	M	K	F	TxL	Weight kg/ib		Kv/Cv		
				1500	2500	1500	2500				1500	2500						1500	2500	1500	2500	
DN250	DN200	mm	201.0	832.0	1022.0	416.0	511.0	425.0	273.0	540.0	485.0	550.0	72.0	76.50	20.0	F25	254.0	18x25	1000	2330	6963	4758
10"	8"	inch	7.91	32.76	40.24	16.38	20.12	16.73	10.75	21.26	19.09	21.65	2.83	3.01	0.79		10.0	(8 holes)	2205	5137	8050	5500
DN300	DN250	mm	252.0	991.0	1270.0	495.50	635.0	582.0	374.0	712.0	585.0	675.0	80.0	87.0	22.0	F30	298.0	22x30	1900	4427	11418	7526
12"	10"	inch	9.92	39.02	50.0	19.51	25.0	22.91	14.72	28.03	23.03	26.57	3.15	3.43	0.87		11.73	(8 holes)	4189	9760	13200	8700

Z91W

Z92W

Z93W

Z94W

Z95W

Z96W

Z91Z

Z92Z

Z93Z

Z94Z

Z95Z

Z96Z

3"-8"

DN80-DN200

High Temperature Trunnion

Ball 3 Piece Up to

W 200°C (400°F)

Z 327°C (620°F)

Components & Materials

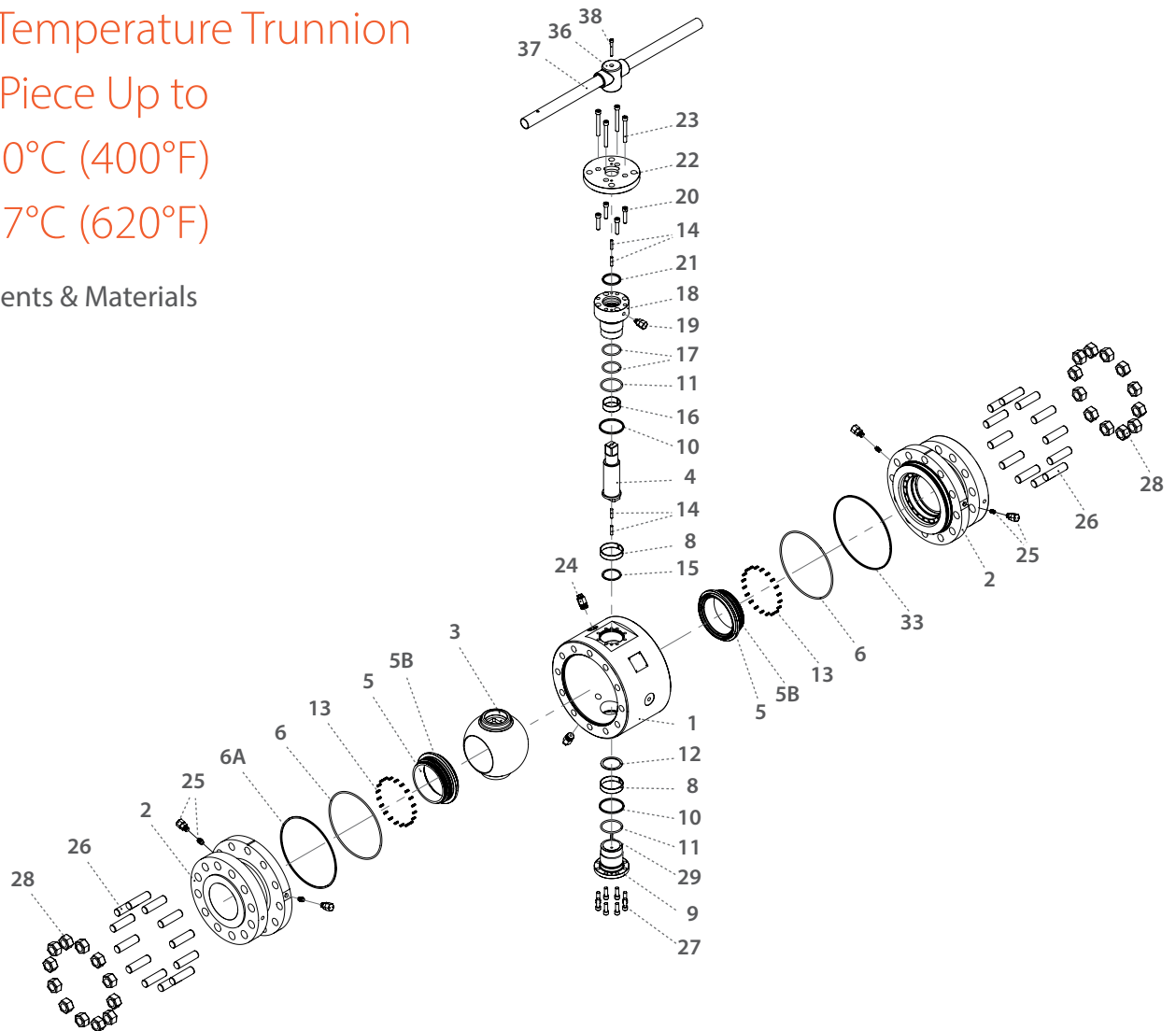

Item	Description	Material Spec. ASTM	Qty.
1	Body	Acc. Ordering code	1
2	Ends	Acc. Ordering code	2
3	Ball	Acc. Ordering code	1
4	Stem	Acc. Ordering code	1
5*	Seat	Acc. Ordering code	2
5B*	Seat Seal	Viton / HNBR	2-4
6*	Body Inner Seal	Viton / HNBR	2
6A*	Body Outer Seal	Graphite	2
8*	Ball Bearing	S.steel 316 + PTFE	2
9	External Trunnion	S.steel / C.steel	1
10*	Gland Plate & External Trunnion Fire Safe Seal	Graphite	2
11*	Gland Plate & External Trunnion Seal	Viton / HNBR	2
12*	Lower Thrust Washer	S.steel 316 + PTFE	1
13	Seat Spring	Inconel X750	28-40
14	Gland Pin	S.steel / C.steel	4
15*	Stem Thrust Washer	S.steel 316 + PTFE	1
16*	Gland Plate Bearing	S.steel 316 + PTFE	1

Item	Description	Material Spec. ASTM	Qty.
17*	Stem Seal	Viton / HNBR	2
18	Gland Plate	S.steel / C.steel	1
19	Stem Grease Fitting	S.steel	1
20	Lower Gland Bolts	A193-B8M / A320 L7	4
21*	Stem Fire Safe Seal	Graphite	1
22	Iso Plate	S.steel / C.steel	1
23	Upper Gland Bolts	A193-B8M / A320 L7	4
24	Plug Valve	S.steel	2
25**	Seat Grease Fitting + Check Valve	S.steel	4
26	Body Studs	A193-B8M / A320 L7	16-24
27	External Trunnion Bolts	A193-B8M / A320 L7	4
28	Body Nuts	A194-8M / A194 L7	16-24
29	Antistatic Spring	Inconel X750	1
30	Wrench Head	S.steel / C.steel	1
31	Wrench Bolt	S.steel / C.steel	1
32	Pipe Handle	S.steel / C.steel Zink plate	1

* Maintenance kit components

** Available from 6" size only

Z91W

Z92W

Z93W

Z94W

Z95W

Z96W



Z91Z

Z92Z

Z93Z

Z94Z

Z95Z

Z96Z

10"-12"
DN250-DN300

High Temperature Trunnion

Ball 3 Piece Up to

W 200°C (400°F)

Z 327°C (620°F)

Components & Materials

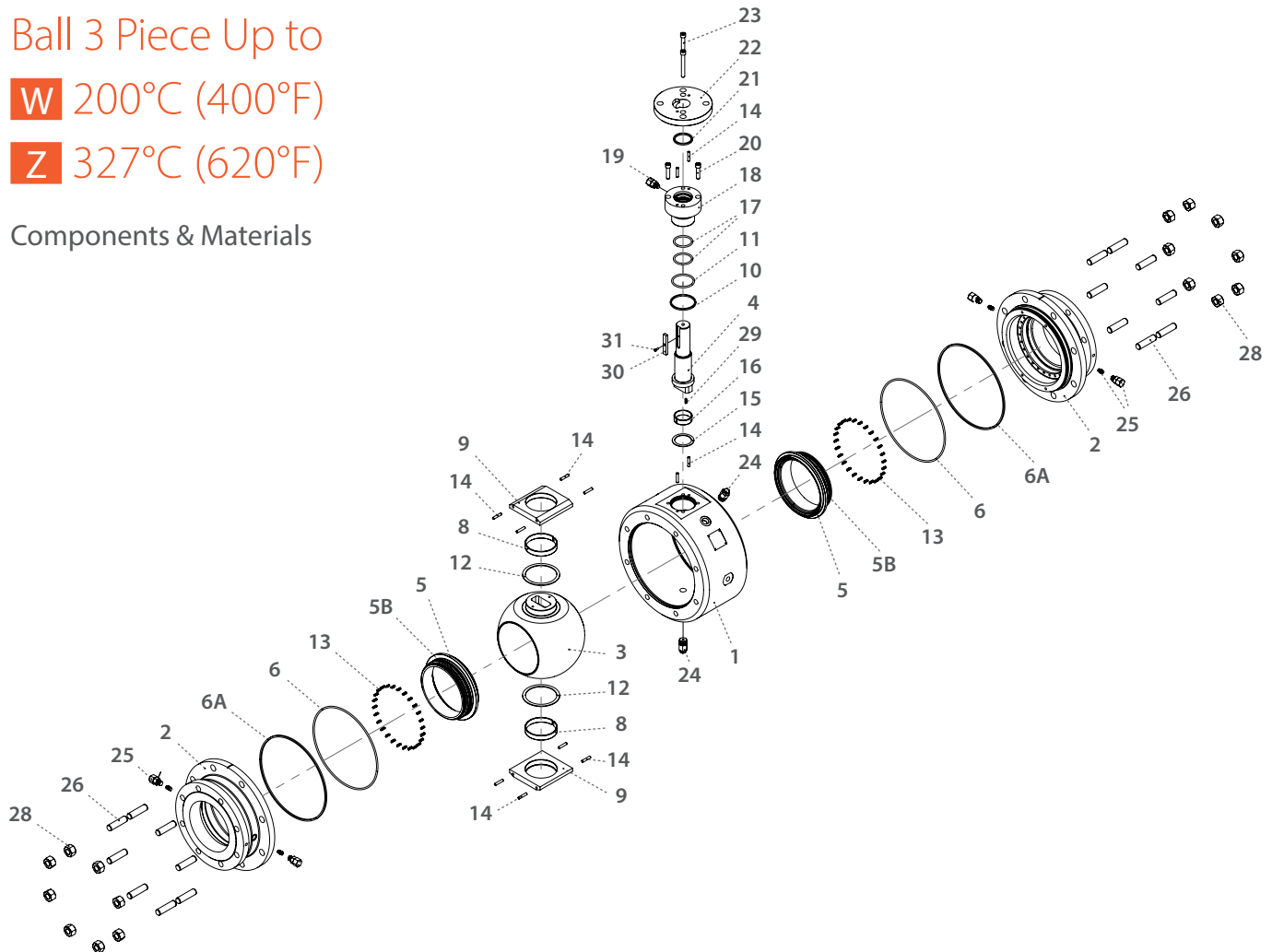

Item	Description	Material Spec. ASTM	Qty.
1	Body	Acc. Ordering code	1
2	Ends	Acc. Ordering code	2
3	Ball	Acc. Ordering code	1
4	Stem	Acc. Ordering code	1
5*	Seat	Acc. Ordering code	2
5B*	Seat Seal	Viton, HNBR	2-4
6*	Body Inner Seal	Viton, HNBR	2
6A*	Body Outer Seal	Graphite	2
8*	Ball Bearing	S.steel 316 + PTFE	2
9	Trunnion Plate	S.steel / C.steel	2
10*	Gland Plate & External Trunnion Fire Safe Seal	Graphite	1
11*	Gland Plate & External Trunnion Seal	Viton, HNBR	1
12*	Ball Thrust Washer	S.steel 316 + PTFE	2
13	Seat Spring	Inconel X750	52-60
14	Gland Pin	S.steel / C.steel	12
15*	Stem Thrust Washer	S.steel 316 + PTFE	1
16*	Stem Bearing	S.steel 316 + PTFE	1

Item	Description	Material Spec. ASTM	Qty.
17*	Stem Seal	Viton, HNBR	2
18	Gland Plate	S.steel / C.steel	1
19	Stem Grease Fitting	S.steel	1
20	Lower Gland Bolts	A193-B8M / A320 L7	2-6
21*	Stem Fire Safe Seal	Graphite	1
22	Iso Plate	S.steel / C.steel	1
23	Upper Gland Bolts	A193-B8M / A320 L7	2-6
24	Plug Valve	S.steel	2
25**	Seat Grease Fitting + Check Valve	S.steel	4
26	Body Studs	A193-B8M / A320 L7	16-32
28	Body Nuts	A194-8M / A194 L7	16-32
29	Antistatic Spring	Inconel X750	1
30	Stem Key	S.steel / C.steel	1
31	Stem Key Bolt	S.steel / C.steel	1

* Maintenance kit components

Z91Q**Z92Q**

3"-8" | DN80-DN200 | CLASS 150/300

High Temperature Trunnion Ball 3 Piece Up to 538°C (1000°F)

Valve Dimensions

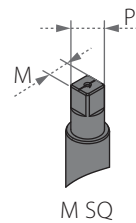
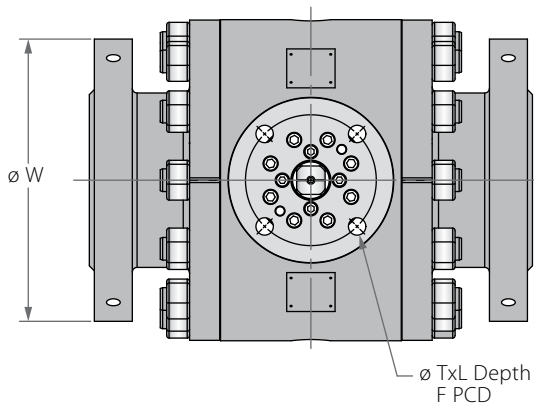
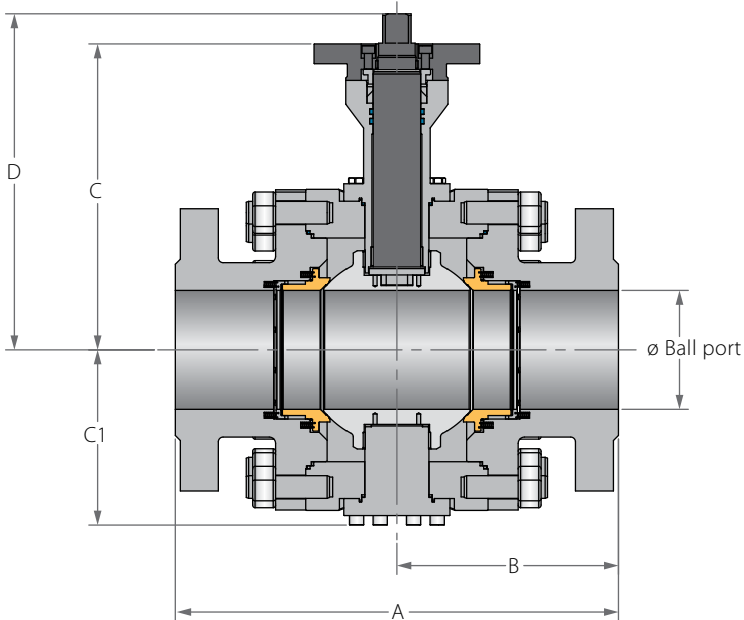

Std. port	Full port	Unit	Ball port	A		B		C	C1	D		M SQ	P SQ	F	TxL	Weight kg/ib		Kv/Cv		
				150	300	150	300			150	300					150	300	150	300	
DN80	DN50	mm	49.0	178.0	216.0	89.0	108.0	250.0	94.0	269.0	150.0	165.0	16.90	F10	102.0	M10X15 (4 holes)	27	31	400	363
3"	2"	inch	1.93	7.01	8.50	3.50	4.25	9.84	3.70	10.59	5.91	6.50	0.67		4.02		60	68	463	420
DN100	DN80	mm	74.0	203.0	283.0	101.50	141.50	277.0	117.0	301.0	190.0	210.0	21.90	F12	125.0	M12X15 (4 holes)	49	63	1125	952
4"	3"	inch	2.91	7.99	11.14	4.0	5.57	10.91	4.61	11.85	7.48	8.27	0.86		4.92		108	139	1300	1100
DN150	DN100	mm	100.0	229.0	305.0	114.50	152.50	293.0	139.0	322.0	230.0	255.0	26.90	F14	140.0	M16X15 (4 holes)	72	96	2154	1860
6"	4"	inch	3.94	9.02	12.0	4.51	6.0	11.54	5.47	12.68	9.06	10.04	1.06		5.51		159	212	2490	2150
DN200	DN150	mm	150.0	394.0	403.0	197.0	201.50	362.0	191.0	400.0	280.0	320.0	35.90	F16	165.0	M22X25 (4 holes)	166	184	4723	4628
8"	6"	inch	5.91	15.51	15.87	7.76	7.93	14.25	7.52	15.75	11.02	12.60	1.41		6.50		366	406	5460	5350

Z91Q**Z92Q**

10"-12" | DN250-DN300 | CLASS 150/300



High Temperature Trunnion Ball 3 Piece Up to 538°C (1000°F)

Valve Dimensions

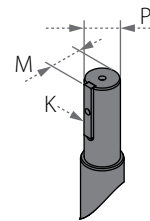
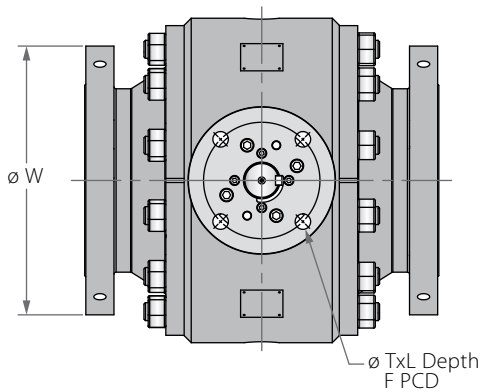
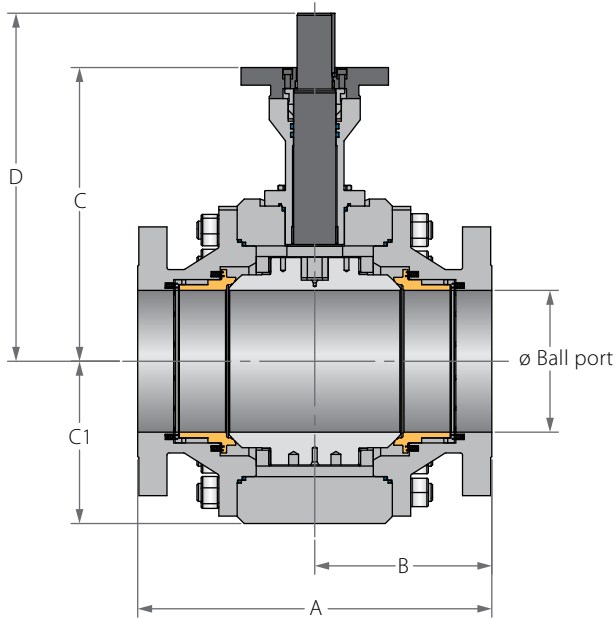

Std. port	Full port	Unit	Ball port	A		B		C	C1	D	M	K	F	TxL	Weight kg/ib		Kv/Cv		
				150	300	150	300								150	300			
DN250	DN200	mm	201.0	457.0	502.0	228.50	251.0	416.0	215.0	493.0	345.0	380.0	50.0	54.0	14.0	346	378	9273	8737
10"	8"	inch	7.91	17.99	19.76	9.0	9.88	16.38	8.46	19.41	13.58	14.96		1.97		763	833	10720	10100
DN300	DN250	mm	252.0	533.0	568.0	266.50	284.0	504.0	260.0	581.0	405.0	445.0	50.0	54.0	14.0	518	639	15224	14792
12"	10"	inch	9.92	20.98	22.36	10.49	11.18	19.84	10.24	22.87	15.94	17.52		1.97		1142	1408	17600	17100

Z93Q

Z94Q

3"-8" | DN80-DN200 | CLASS 600/900

High Temperature Trunnion Ball 3 Piece Up to 538°C (1000°F)

Valve Dimensions

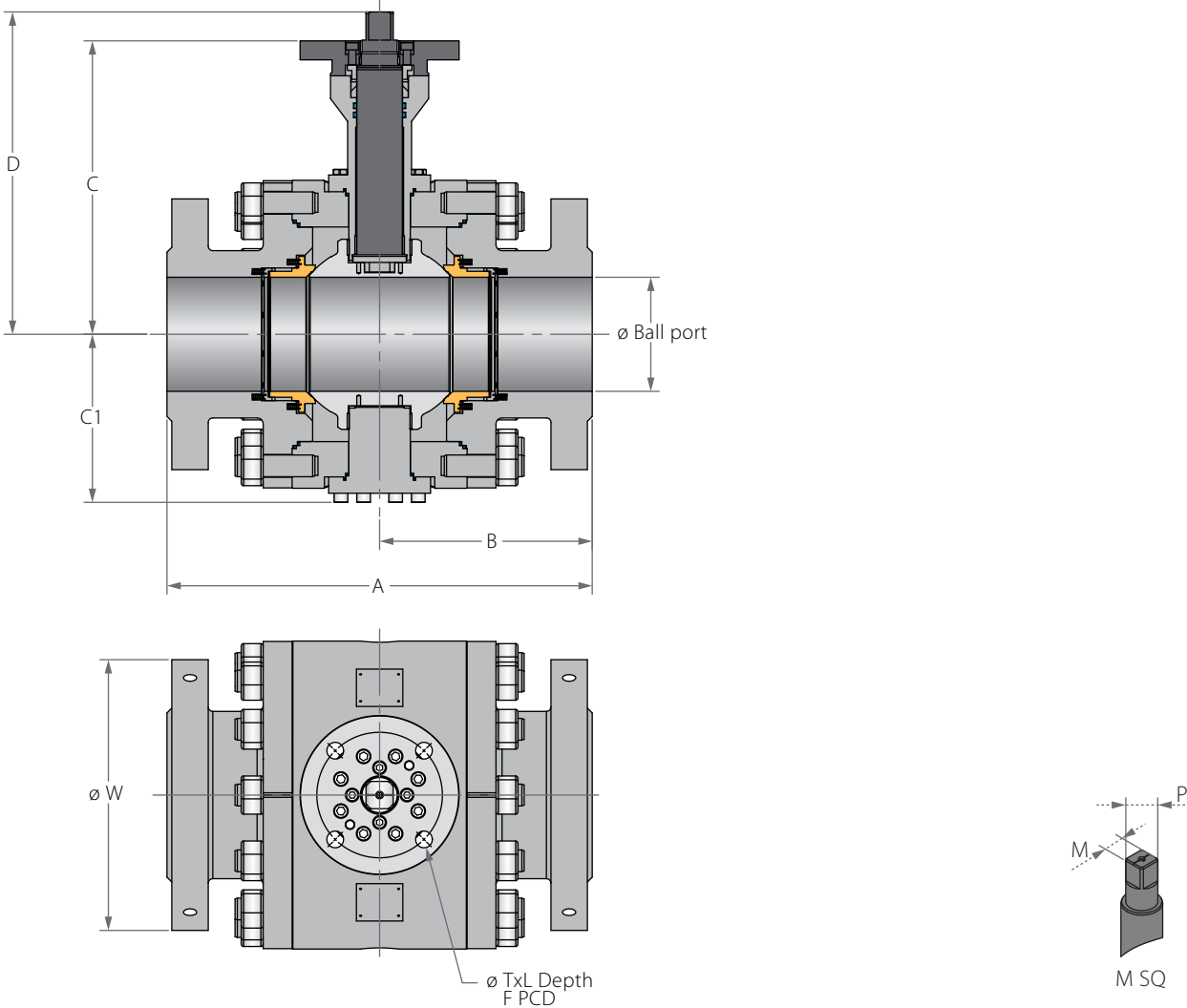

Std. port	Full port	Unit	Ball port	A		B		C		C1		D		W		M SQ	P SQ	F	TxL	Weight kg/ib				Kv/Cv	
				600	900	600	900	600	900	600	900	600	900	600	900					600	900	600	900		
DN80	DN50	mm	49.0	292.0	368.0	146.0	184.0	272.0	272.0	119.0	119.0	291.0	291.0	165.0	215.0	16.90	21.30	F12	125.0	M12X15	49	67	329	294	
3"	2"	inch	1.93	11.50	14.49	5.75	7.24	10.71	10.71	4.69	4.69	11.46	11.46	6.50	8.46	0.67	0.84		4.92	(4 holes)	108	148	380	340	
DN100	DN80	mm	74.0	356.0	381.0	178.0	190.50	306.0	306.0	160.0	160.0	330.0	330.0	210.0	240.0	21.90	26.90	F12	125.0	M12X15	95	114	874	822	
4"	3"	inch	2.91	14.02	15.0	7.01	7.50	12.05	12.05	6.30	6.30	12.99	12.99	8.27	9.45	0.86	1.06		4.92	(4 holes)	209	251	1010	950	
DN150	DN100	mm	100.0	432.0	457.0	216.0	228.50	334.0	334.0	184.0	184.0	364.0	364.0	275.0	290.0	26.90	34.90	F16	165.0	M22X25	165	186	1557	1471	
6"	4"	inch	3.94	17.01	17.99	8.50	9.0	13.15	13.15	7.24	7.24	14.33	14.33	10.83	11.42	1.06	1.37		6.50	(4 holes)	364	410	1800	1700	
DN200	DN150	mm	150.0	559.0	610.0	279.50	305.0	386.0	404.0	220.0	220.0	424.0	442.0	355.0	380.0	35.90	46.20	F16	165.0	M22X25	340	418	3893	3823	
8"	6"	inch	5.91	22.01	24.02	11.0	12.01	15.20	15.91	8.66	8.66	16.69	17.40	13.98	14.96	1.41	1.82		6.50	(4 holes)	750	922	4500	4420	

Z93Q**Z94Q**

10"-12" | DN250-DN300 | CLASS 600/900



High Temperature Trunnion Ball 3 Piece Up to 538°C (1000°F)

Valve Dimensions

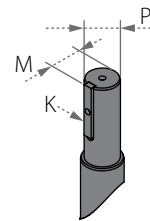
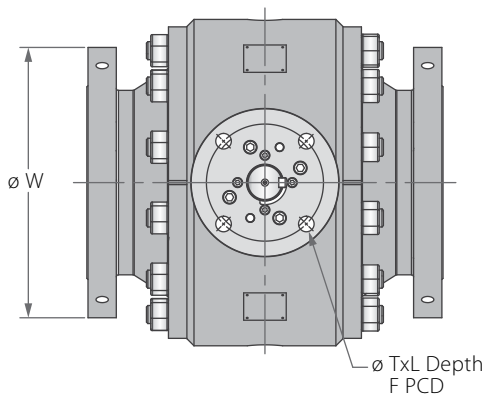
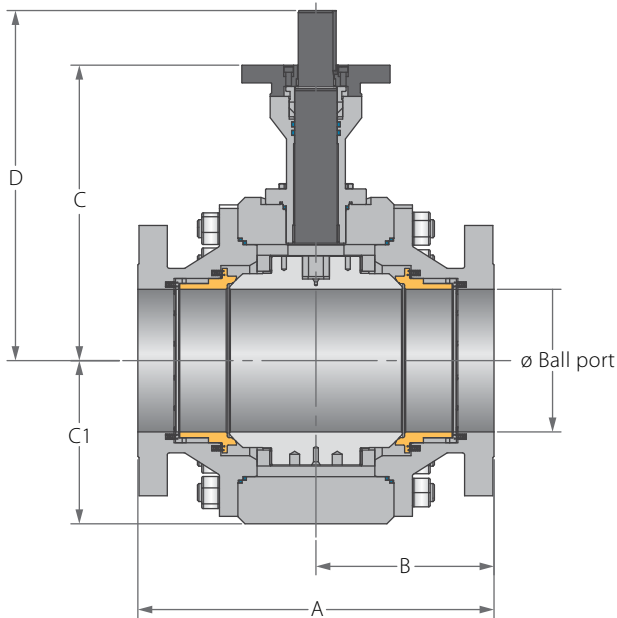

Std. port	Full port	Unit	Ball port	A		B		C		C1		D		W		P	M	K	F	TxL	Weight kg/lb		Kv/Cv		
				600	900	600	900	600	900	600	900	600	900	600	900						600	900			
DN250	DN200	mm	201.0	660.0	737.0	330.0	368.50	418.0	418.0	263.0	263.0	515.0	515.0	420.0	470.0	72.0	76.50	20.0	F25	254.0	18x25	548	789	7742	7344
10"	8"	inch	7.91	25.98	29.02	12.99	14.51	16.46	16.46	10.35	10.35	20.28	20.28	16.54	18.50	2.83	3.01	0.79		10.0	(8 holes)	1208	1739	8950	8490
DN300	DN250	mm	252.0	787.0	838.0	393.50	419.0	519.0	537.0	310.0	326.0	616.0	634.0	510.0	545.0	72.0	76.50	20.0	F30	298.0	22x30	895	1274	12543	12110
12"	10"	inch	9.92	30.98	32.99	15.49	16.50	20.43	21.14	12.20	12.83	24.25	24.96	20.08	21.46	2.83	3.01	0.79		11.73	(8 holes)	1973	2809	14500	14000

Z95Q**Z96Q**

3"-8" | DN80-DN200 | CLASS 1500/2500

High Temperature Trunnion Ball 3 Piece Up to 538°C (1000°F)

Valve Dimensions

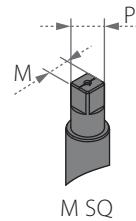
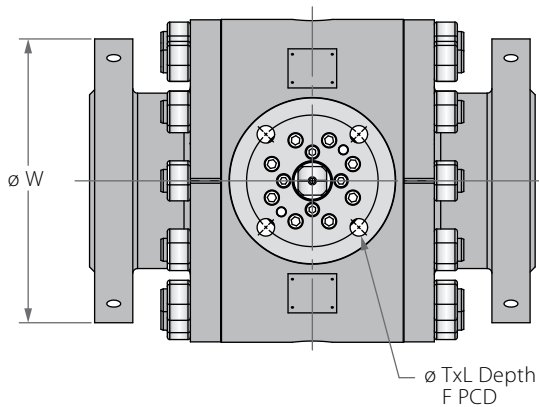
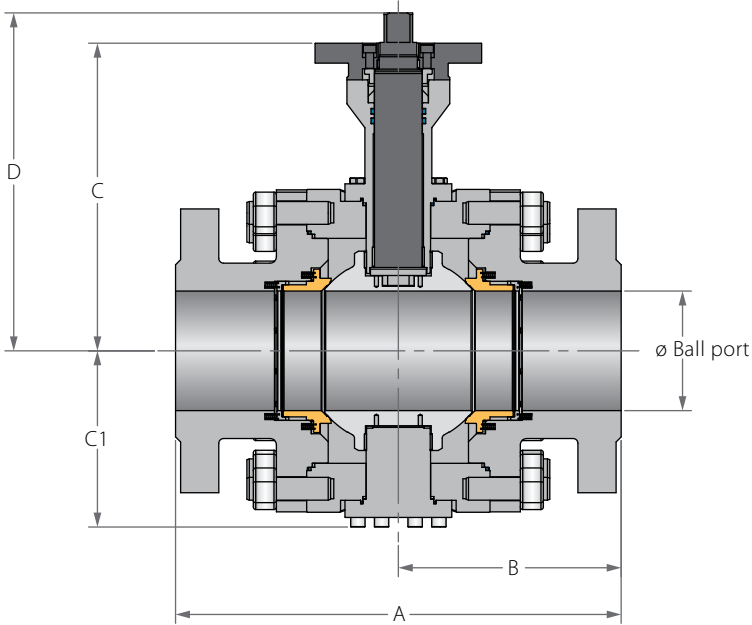

Std. port	Full port	Unit	Ball port		A		B		C	C1	D	W		M SQ	P SQ	F	TxL	Weight kg/ib		Kv/Cv		
			1500	2500	1500	2500	1500	2500				1500	2500					1500	2500	1500	2500	
DN80	DN50	mm	49.0	42.0	368.0	451.0	184.0	225.50	325.0	127.0	330.0	215.0	235.0	22.0	32.0	F14	140.0	18X12	90	179	281	260
3"	2"	inch	1.93	1.65	14.49	17.76	7.24	8.88	12.80	5.0	12.99	8.46	9.25	0.87	1.26		5.51	(4 holes)	198	395	325	300
DN100	DN80	mm	74.0	62.0	470.0	578.0	235.0	289.0	379.0	201.50	408.0	265.0	305.0	27.0	35.0	F14	140.0	18x22	175	340	735	649
4"	3"	inch	2.91	2.44	18.50	22.76	9.25	11.38	14.92	7.93	16.06	10.43	12.01	1.06	1.38		5.51	(4 holes)	386	750	850	750
DN150	DN100	mm	100.0	87.0	546.0	673.0	273.0	336.50	408.0	198.50	446.0	310.0	355.0	36.0	46.20	F16	165.0	22x25	330	646	1384	1228
6"	4"	inch	3.94	3.43	21.50	26.50	10.75	13.25	16.06	7.81	17.56	12.20	13.98	1.42	1.82		6.50	(4 holes)	728	1424	1600	1420
DN200	DN150	mm	144.0	131.0	705.0	914.0	352.50	457.0	538.0	272.0	586.0	395.0	485.0	46.0	59.0	F25	254.0	22x30	627	1227	3590	2206
8"	6"	inch	5.67	5.16	27.76	35.98	13.88	17.99	21.18	10.71	23.07	15.55	19.09	1.81	2.32		10.0	(8 holes)	1382	2705	4150	2550

Z95Q**Z96Q**

10"-12" | DN250-DN300 | CLASS 1500/2500



High Temperature Trunnion Ball 3 Piece Up to 538°C (1000°F)

Valve Dimensions

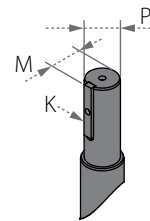
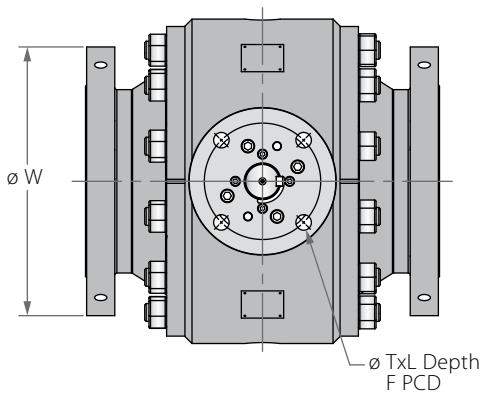
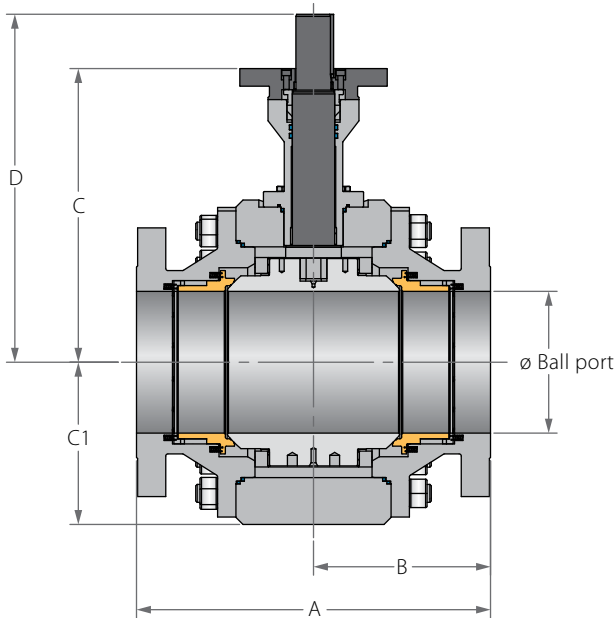

Std. port	Full port	Unit	Ball port		A		B		C	C1	D	W		P	M	K	F	TxL	Weight kg/ib		Kv/Cv		
			1500	2500	1500	2500	1500	2500				1500	2500						1500	2500	1500	2500	
DN250	DN200	mm	192.0	179.0	832.0	1022.0	416.0	511.0	498.0	273.0	628.0	485.0	550.0	98.0	104.40	28.0	F30	298.0	22x30	1000	2330	6963	4758
10"	8"	inch	7.56	7.05	32.76	40.24	16.38	20.12	19.61	10.75	24.72	19.09	21.65	3.86	4.11	1.10		11.73	(8 holes)	2205	5137	8050	5500
DN300	DN250	mm	239.0	223.0	991.0	1270.0	495.50	635.0	609.0	374.0	740.0	585.0	675.0	98.0	104.40	28.0	F35	356.0	32x45	1900	3623	11418	7389
12"	10"	inch	9.41	8.78	39.02	50.0	19.51	25.0	23.98	14.72	29.13	23.03	26.57	3.86	4.11	1.10		14.02	(8 holes)	4189	7987	13200	8542

Z91Q

Z92Q

Z93Q

Z94Q

Z95Q

Z96Q

3"-8" | DN80-DN200

High Temperature Trunnion Ball 3 Piece Up to 538°C (1000°F)

Components & Materials

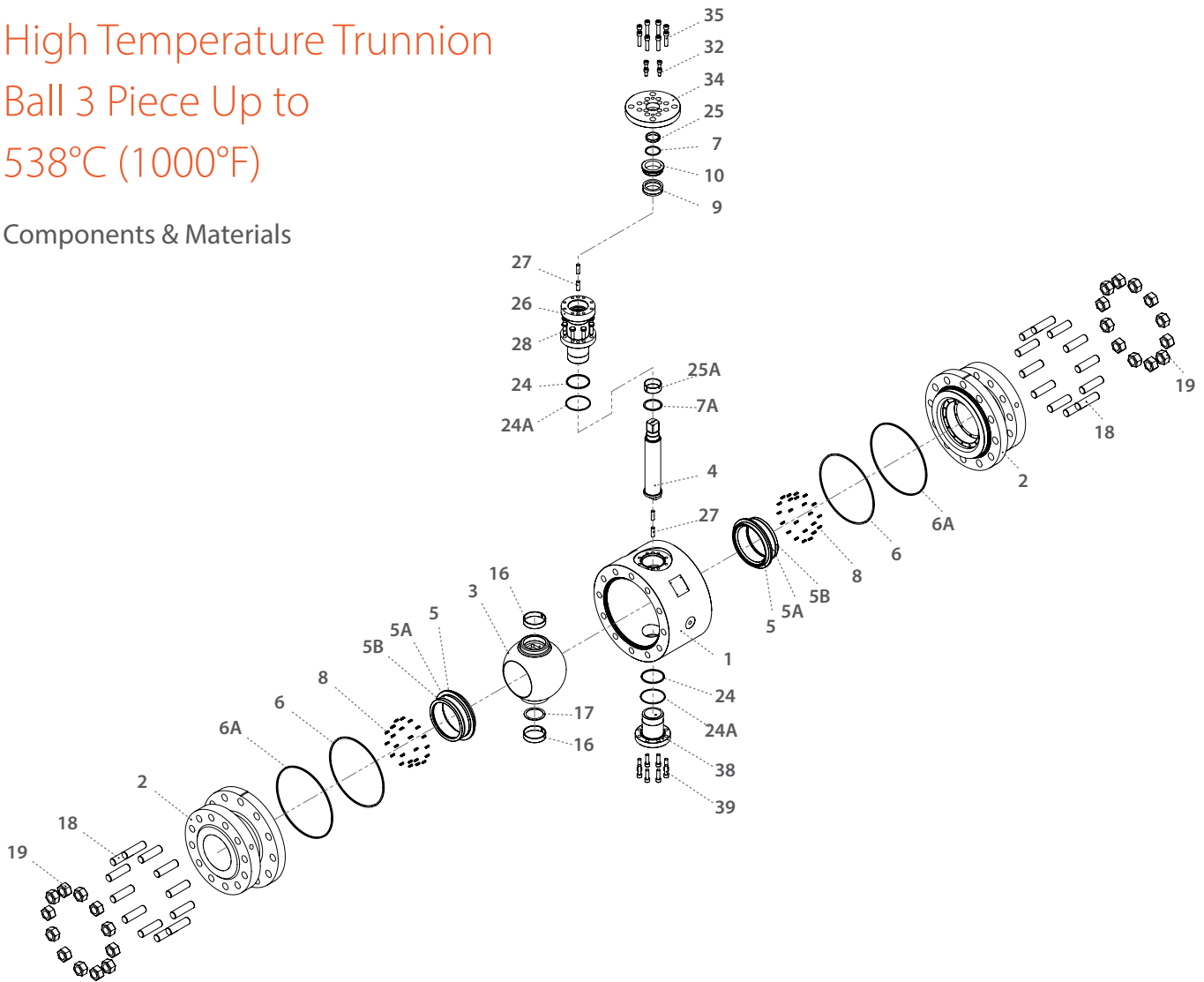

Item	Description	Material Spec. ASTM	Qty.
1	Body	Acc. Ordering Code	1
2	End	Acc. Ordering Code	2
3	Ball	Acc. Ordering Code	1
4	Stem	Acc. Ordering Code	1
5*	Seat	Acc. Ordering Code	2
5A*	Seat Seal	Graphite	2
5B*	Seat Ring	Acc. Ordering Code	2
6*	Body Inner Seal	Graphite	2
6A*	Body Outer Seal	Graphite	2
7	Upper Thrust Seal	S.steel 316 / Inconel 625	1
7A	Lower Thrust Seal	S.steel 316 / Inconel 625	1
8	Seat Spring	Inconel X750	16-48
9*	Stem Seal	Graphite	1
10	Follower	S.steel	1
16	Ball Bearing	Inconel 625	2
17	Ball Thrust Seal	Inconel 625	1

Item	Description	Material Spec. ASTM	Qty.
18	Body Stud	A193-B8M / A320 L7	8-24
19	Body Nuts	A194 8M / A194 L7	8-24
24*	Bonnet Inner Seal	Graphite	2
24A*	Bonnet Outer Seal	Graphite	2
25	Upper Stem Bearing	Inconel 625	1
25A	Lower Stem Bearing	Inconel 625	1
26	Bonnet	S. steel / C. steel	1
27	Bonnet Pin	S. steel / C. steel	4
28	Bonnet Bolts	A193-B8M / A320 L7	4-8
32	Follower Drive Bolts	A193-B8M / A320 L7	4-8
34	Iso Plate	S. steel / C. steel	1
35	Iso Plate Bolts	A193-B8M / A320 L7	4-8
38	External Trunnion	S. steel / C. steel	1
39	External Trunnion Bolts	A193-B8M / A320 L7	4-8

* Maintenance kit components

Z91Q

Z92Q

Z93Q



Z94Q

Z95Q

Z96Q

10"-12" | DN250-DN300

High Temperature Trunnion Ball 3 Piece Up to 538°C (1000°F)

Components & Materials

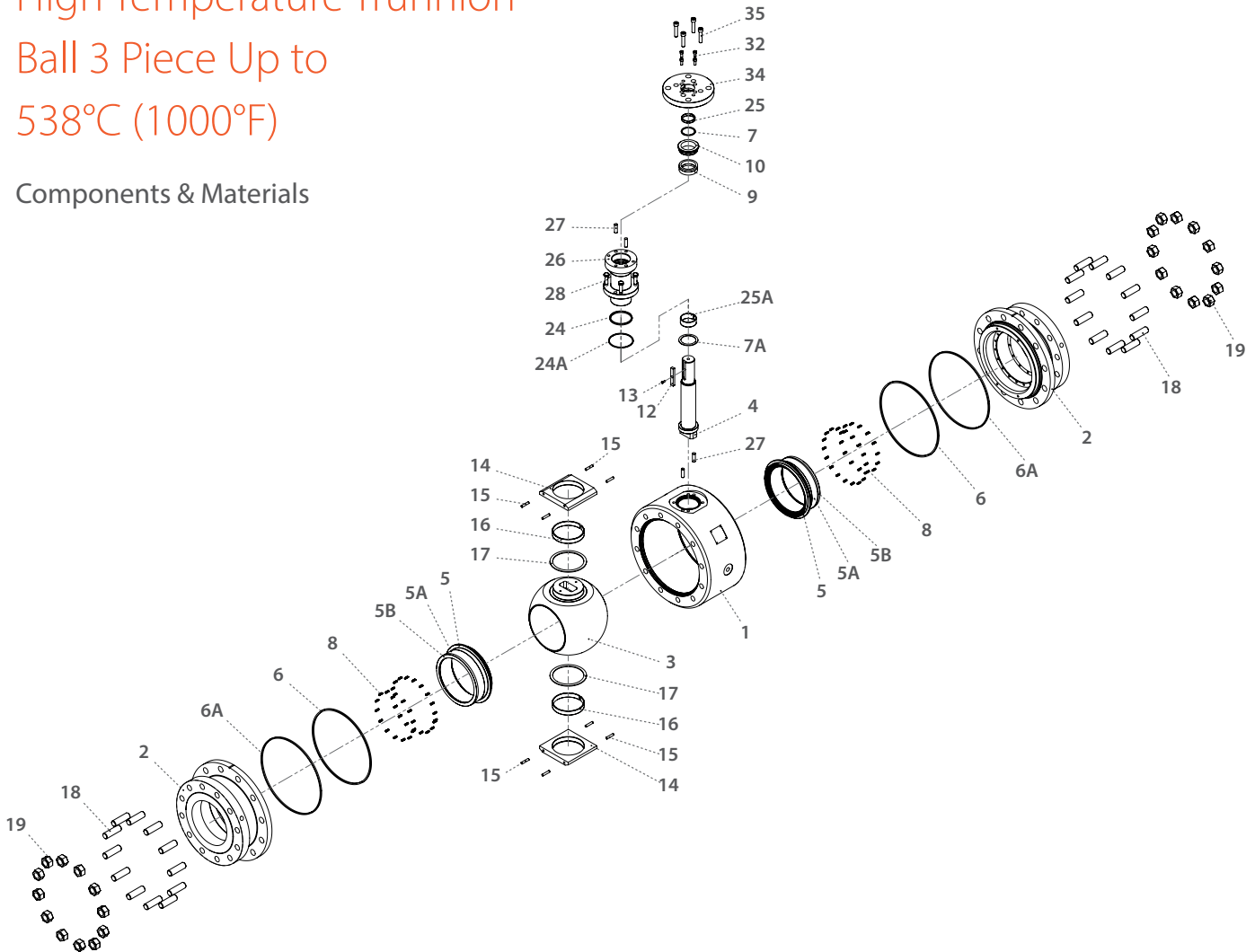

Item	Description	Material Spec. ASTM	Qty.
1	Body	Acc. Ordering code	1
2	End	Acc. Ordering code	2
3	Ball	Acc. Ordering code	1
4	Stem	Acc. Ordering code	1
5*	Seat	Acc. Ordering code	2
5A*	Seat Seal	Graphite	2
5B*	Seat Ring	Acc. Ordering code	2
6*	Body Inner Seal	Graphite	2
6A*	Body Outer Seal	Graphite	2
7	Upper Thrust Seal	Inconel 625	1
7A	Lower Thrust Seal	Inconel 625	1
8	Seat Spring	Inconel X750	68-76
9*	Stem Seal	Graphite	1
10	Follower	S.steel	1
12	Stem Key	S.steel / C.steel	1
13	Stem Key Bolt	S.steel / C.steel	1

Item	Description	Material Spec. ASTM	Qty.
14	Trunnion Plate	S.steel / C.steel	2
15	Trunnion Plate Pin	S.steel / C.steel	8
16	Ball Bearing	Inconel 625	2
17	Ball Thrust Washer	Inconel 625	2
18	Body Stud	A193-B8M / A320 L7	16-40
19	Body Nuts	A194 8M / A194 L7	16-40
24*	Bonnet Inner Seal	Graphite	1
24A*	Bonnet Outer Seal	Graphite	1
25	Upper Stem Bearing	Inconel 625	1
25A	Lower Stem Bearing	Inconel 625	1
26	Bonnet	S.steel / C.steel	1
27	Bonnet Pin	S.steel / C.steel	4
28	Bonnet Bolts	ASTM A320-B8M	4-8
32	Follower Drive Bolts	ASTM A320-B8M	4-8
34	Iso Plate	S.steel / C.steel	1
35	Iso Plate Bolts	A193-B8M / A320 L7	4-8

* Maintenance kit components

Z91

Z92

Z93

Z94

Z95

Z96



High Temperature Trunnion Ball 3 Piece - Ordering Code System

"Mandatory option" options are marked with **green background** | "Standard offer" options are marked with **light green background**

1	2	3	4	5	6	7	8	9	10	11	12	13	14	15	16	17	18	19	20	21	22	23	24	...	30
6	0				Z	9	4	W	-	6	M	6	D	I	V	G	/	9	0	0					
Size		Features				Series		Design		Body & ends material		Stem material	Ball/Seat material	Seat feature	Hardening	Inner Seal	Outer Seal	End Connection				Special features			

Size (1-2)		
Code	inch	mm
20*	2"	50
30	3"	80
40	4"	100
60	6"	150
80	8"	200
A0	10"	250
A2**	12"	300

* Full port only
** Z91-Z94 Only

Features (3-6)	
Z	Metal seats
B	Full port

Series - 3 Piece (7-8)	
91	ASME B16.5 #150
92	ASME B16.5 #300
93	ASME B16.5 #600
94	ASME B16.5 #900
95	ASME B16.5 #1500
96	ASME B16.5 #2500

Design (9)	
W	-46°C to 200°C (-50°F to 400°F)
Z	-46°C to 327°C (-50°F to 620°F)
Q	-60°C to 538°C (-76°F to 1000°F)

Body & ends (11)	
4*	C. Steel A105
6	S. Steel A479 316
J**	F22

* -29°C to 425°C (-20°F to 800°F)
** For Q design only

Stem (12)	
M	High Strength S. Steel
Z	Inconel 718

Ball / Seat material (13)	
6	S. Steel A182 316
N*	ASTM A182 F6A (S.Steel 410)

* For O hardening only

Seat feature (14)	
D	Double Piston Effect (DPE) (API 6D DIB-1)
S	Single Piston Effect (SPE) (API 6D DBB)

Hardening (15)	
I	Cr3C2- Chromium Carbide with Nickel Chrome binder - HVOF technique
O*	WC-Co- Tungsten Carbide with Cobalt binder HVO technique

Inner Seal material (16)	
V	Viton (-20°C to 200°C [-4°F to 400°F])
H	HNBR (-46°C to 150°C [-50°F to 300°F])
K	Kalrez (-20°C to 327°C [-4°F to 620°F])
G	Graphite

* Up to 538°C

Outer Seal material (17)	
G	Graphite

End connections (19-22)	
Welded	
XBW	Extended butt weld sch 40
XBW80	Extended butt weld sch 80
XBW160	Extended butt weld sch 160
XBWXXS	Extended butt weld sch XXS

Flanged	
150	ASME B16.5 #150
300	ASME B16.5 #300
600	ASME B16.5 #600
900	ASME B16.5 #900
1500	ASME B16.5 #1500
2500	ASME B16.5 #2500
PN16	DIN EN 1092-1 PN16
PN40	DIN EN 1092-1 PN40
PN63	DIN EN 1092-1 PN63
PN100	DIN EN 1092-1 PN100
PN160	DIN EN 1092-1 PN160
PN250	DIN EN 1092-1 PN250
PN320	DIN EN 1092-1 PN320
PN400	DIN EN 1092-1 PN400

Flanged RTJ	
600RTJ	ASME B16.5 #600 RTJ
900RTJ	ASME B16.5 #900 RTJ
1500RTJ	ASME B16.5 #1500 RTJ
2500RTJ	ASME B16.5 #2500 RTJ

Special features (23-30)	
L*	Seat greasing point
D**	Drain & Vent
Blank	Drain & vent is capped
H**	Drain ball valve & vent
PT***	Basic paint system
PT1	Offshore, Temp Ambient up to 93°C (200°F)
PT2	Offshore, up to 537°C (998°F)

* for 6" Full Bore and up, not for Q-design

** not for Q-design

*** colors RAL 1018 or 7036

(other colors upon request)

Z81 Z82 Z83



High Temp. Valves

TRUNNIION

2 PIECE

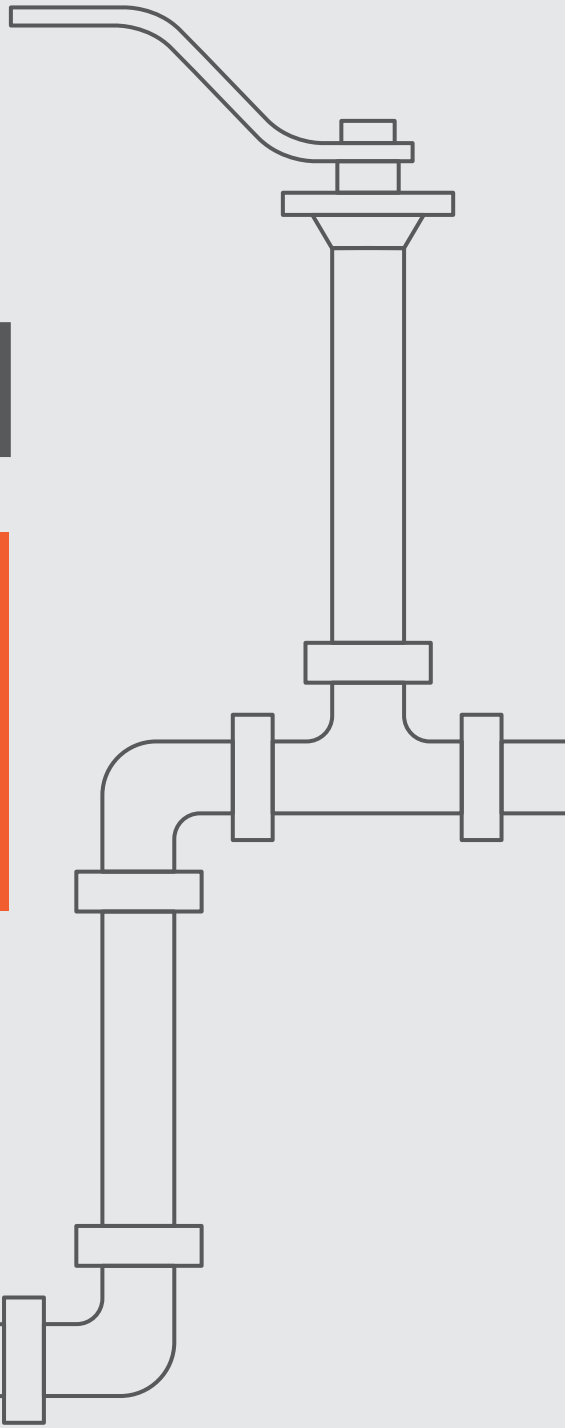

Z81Z**Z81W****Z82Z****Z82W**2"-6" | DN50-DN150
CLASS 150/300

High Temperature Trunnion Ball 2 Piece Up to 327°C (620°F)

W 200°C (400°F) | **Z** 327°C (620°F)

Valve Dimensions

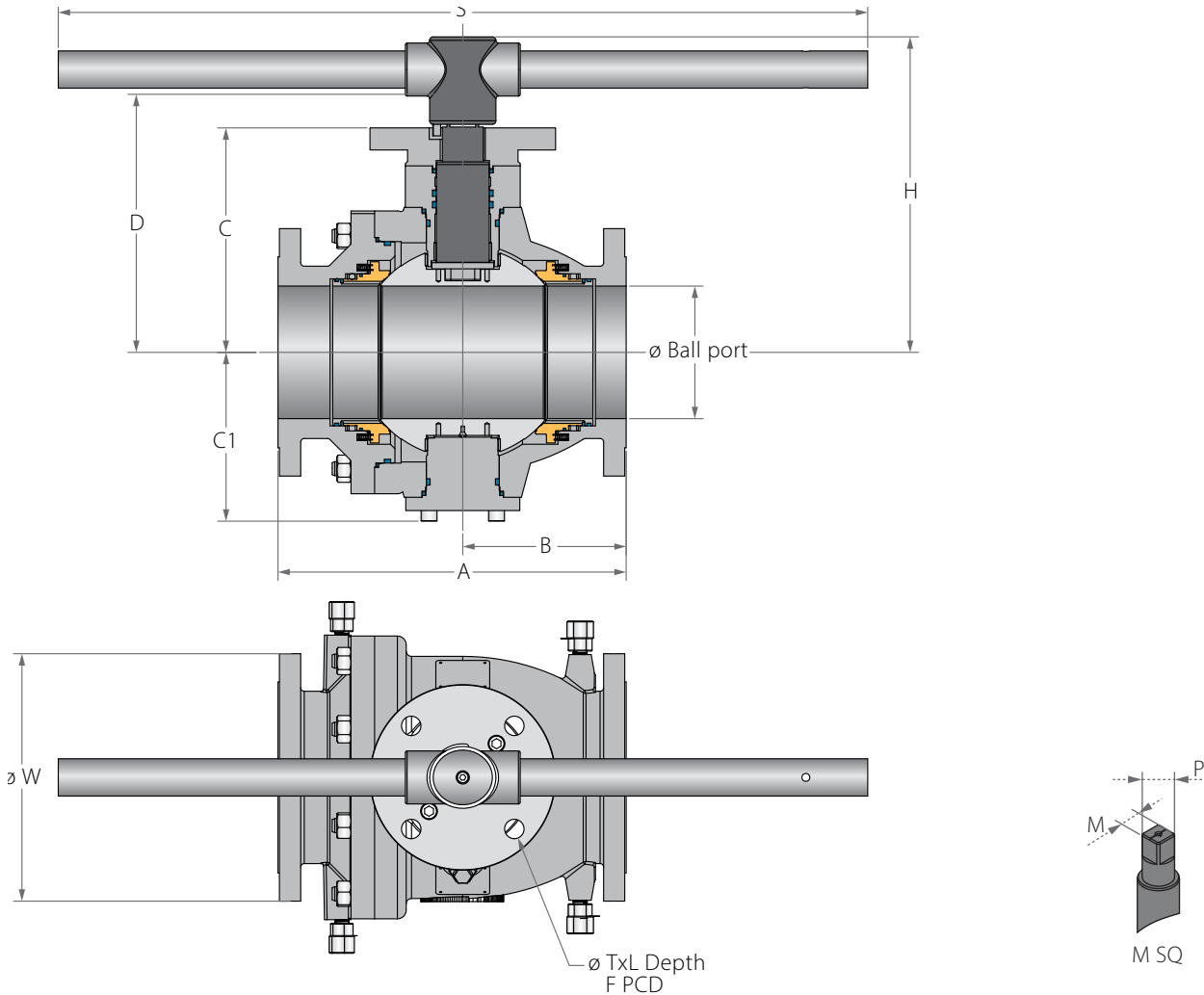

Full port	Unit	Ball port	A		B		C	C1	D	W		M SQ	P SQ	H	S	F	TxL	Weight kg/lb				Kv/Cv	
			150	300	150	300				150	300							150	300	150	300		
DN50	mm	49.0	178.0	216.0	89.0	108.0	127.0	91.50	144.50	150.0	165.0	17.0	22.0	196.0	401.0	F10	102.0	11X15 (4 holes)	19	23	400	363	
2"	inch	1.93	7.01	8.50	3.50	4.25	5.0	3.60	5.69	5.91	6.50	0.67	0.87	7.72	15.79		4.02		42	51	463	420	
DN80	mm	74.0	203.0	283.0	101.50	128.0	148.0	117.0	172.0	190.0	210.0	22.0	32.0	223.0	610.0	F12	125.0	13X15 (4 holes)	33	44	1125	952	
3"	inch	2.91	7.99	11.14	4.0	5.04	5.83	4.61	6.77	7.48	8.27	0.87	1.26	8.78	24.02		4.92		73	97	1300	1100	
DN100	mm	100.0	229.0	305.0	114.50	140.50	171.0	139.0	198.50	230.0	255.0	27.0	35.0	247.50	610.0	F14	140.0	18X15 (4 holes)	49	69	2154	1860	
4"	inch	3.94	9.02	12.0	4.51	5.53	6.73	5.47	7.81	9.06	10.04	1.06	1.38	9.74	24.02		5.51		108	152	2490	2150	
DN150	mm	150.0	394.0	403.0	185.0	230.40	254.0	191.0	290.50	280.0	320.0	36.0	46.20	356.50	916.0	F16	165.0	22X25 (4 holes)	133	166	4723	4628	
6"	inch	5.91	15.51	15.87	7.28	9.07	10.0	7.52	11.44	11.02	12.60	1.42	1.82	14.04	36.06		6.50		293	366	5460	5350	

Z81Z**Z81W****Z82Z****Z82W**8"-12" | DN200-DN300
CLASS 150/300

High Temperature Trunnion Ball 2 Piece Up to 327°C (620°F)

W 200°C (400°F) | **Z** 327°C (620°F)

Valve Dimensions

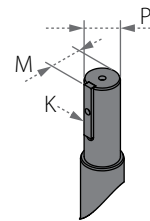
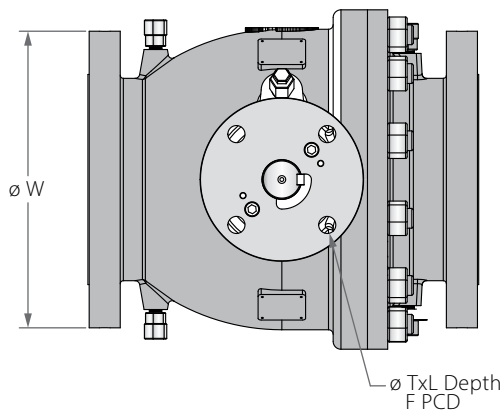
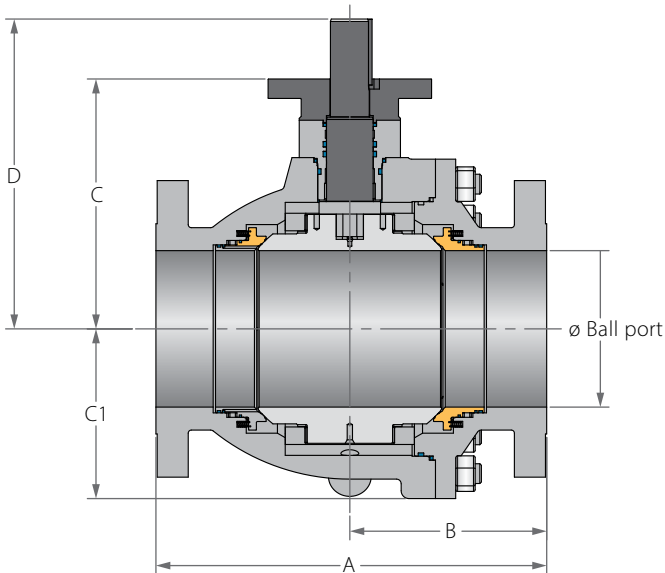

Full port	Unit	Ball port	A		B		C	C1	D	W		P	M	K	F	TxL	Weight kg/ib		Kv/Cv		
			150	300	150	300				150	300						150	300	150	300	
DN200	mm	201.0	457.0	502.0	228.50	253.0	325.0	247.0	405.50	345.0	380.0	50.0	54.0	14.0	F16	165.0	22x25	222	262	9273	8737
8"	inch	7.91	17.99	19.76	9.0	9.96	12.80	9.72	15.96	13.58	14.96	1.97	2.13	0.55		6.50	(4 holes)	489	578	10720	10100
DN250	mm	252.0	533.0	568.0	270.0	287.50	353.0	297.0	430.0	405.0	445.0	50.0	54.0	14.0	F25	254.0	18x25	358	424	15224	14792
10"	inch	9.92	20.98	22.36	10.63	11.32	13.90	11.69	16.93	15.94	17.52	1.97	2.13	0.55		10.0	(8 holes)	789	935	17600	17100
DN300	mm	303.0	610.0	648.0	298.0	313.0	388.0	324.0	468.50	485.0	520.0	60.0	63.50	18.0	F25	254.0	18x25	527	613	23096	22404
12"	inch	11.93	24.02	25.51	11.73	12.32	15.28	12.76	18.44	19.09	20.47	2.36	2.50	0.71		10.0	(8 holes)	1162	1351	26700	25900

Z83Z**Z83W**

2"-6" | DN50-DN150 | CLASS 600

High Temperature Trunnion Ball 2 Piece Up to 327°C (620°F)

W 200°C (400°F) | **Z** 327°C (620°F)

Valve Dimensions

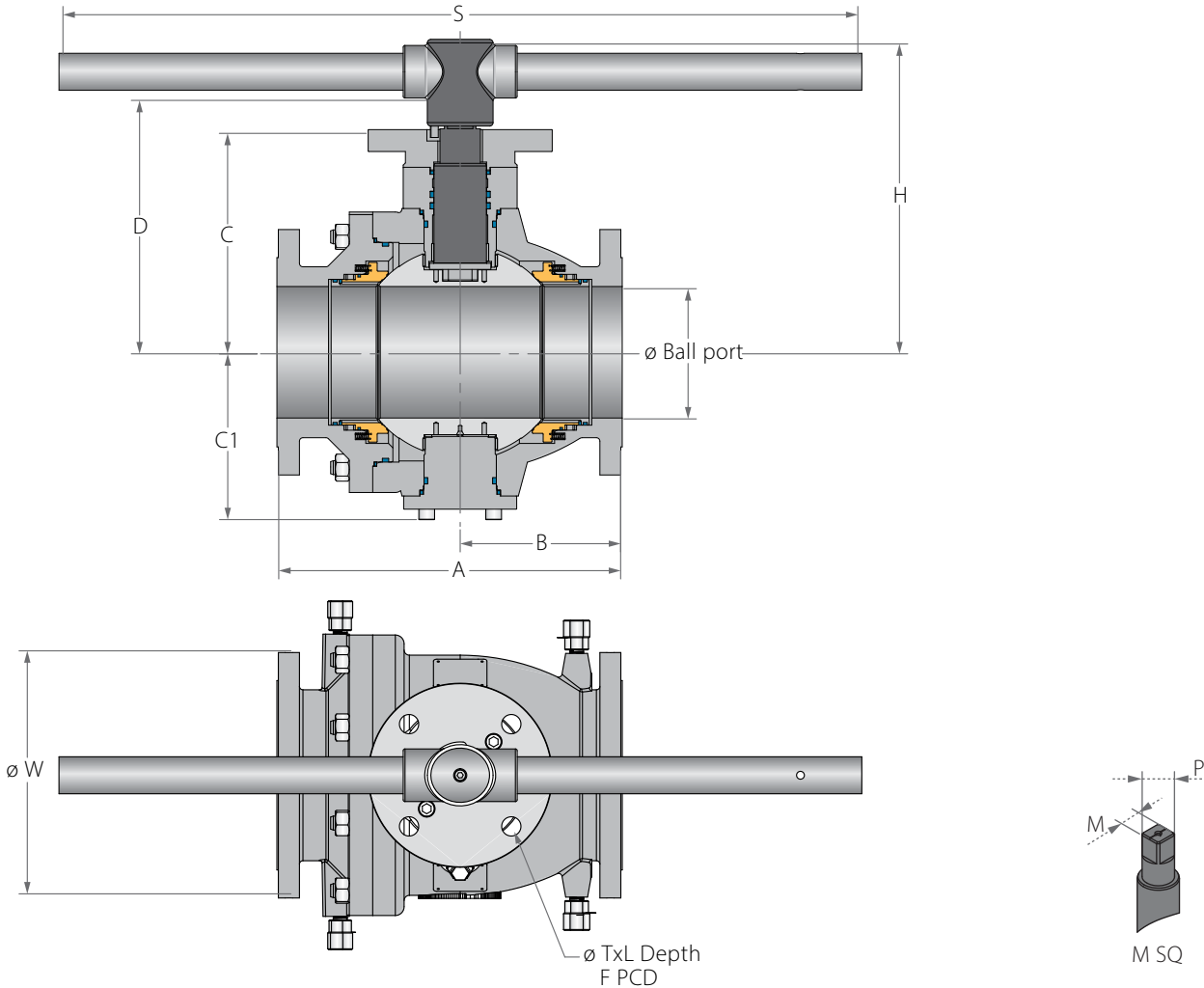

Full port	Unit	Ball port	A	B	C	C1	D	W	M SQ	P SQ	H	S	F	TxL	Weight kg/lb	Kv/Cv	
DN50	mm	49.0	292.0	131.0	144.0	119.0	168.50	165.0	22.0	28.0	219.50	401.0	F12	125.0	13X15 (4 holes)	35	329
2"	inch	1.93	11.50	5.16	5.67	4.69	6.63	6.50	0.87	1.10	8.64	15.79		4.92		77	380
DN80	mm	74.0	356.0	161.0	191.0	160.0	215.0	210.0	22.0	28.0	266.0	610.0	F12	140.0	18X24 (4 holes)	71	874
3"	inch	2.91	14.02	6.34	7.52	6.30	8.46	8.27	0.87	1.10	10.47	24.02		5.51		157	1010
DN100	mm	100.0	432.0	216.0	217.0	184.0	246.50	275.0	27.0	36.0	316.50	916.0	F16	165.0	22X25 (4 holes)	123	1557
4"	inch	3.94	17.01	8.50	8.54	7.24	9.70	10.83	1.06	1.42	12.46	36.06		6.50		271	1800
DN150	mm	150.0	559.0	278.0	282.50	214.50	320.50	355.0	36.0	48.20	385.0	916.0	F16	165.0	22X25 (4 holes)	244	3893
6"	inch	5.91	22.01	10.94	11.12	8.44	12.62	13.98	1.42	1.90	15.16	36.06		6.50		538	4500

Z83Z**Z83W**

8"-12" | DN200-DN300 | CLASS 600



High Temperature Trunnion Ball 2 Piece Up to 327°C (620°F)

W 200°C (400°F) | **Z** 327°C (620°F)

Valve Dimensions

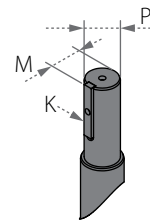
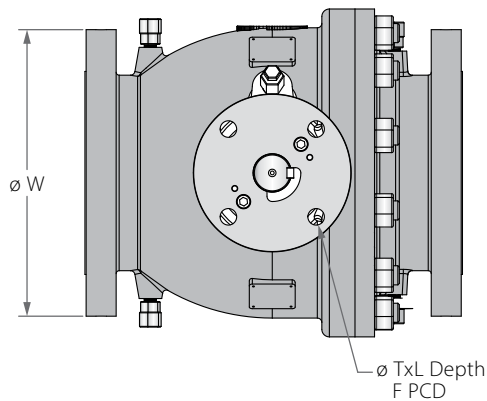
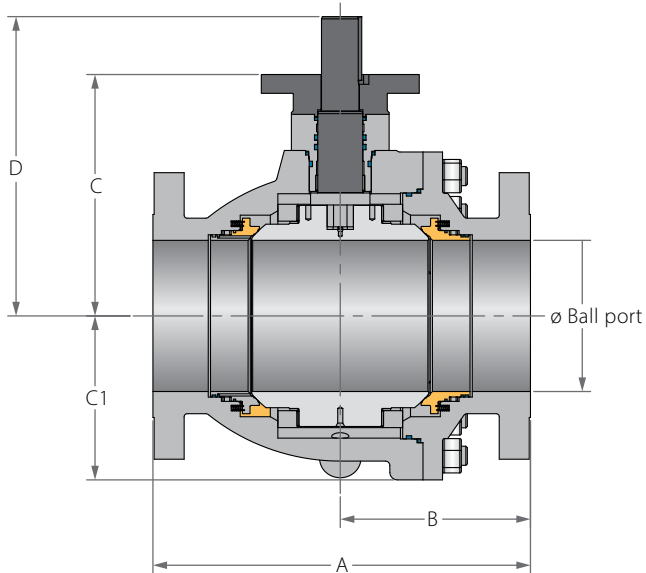

Full port	Unit	Ball port	A	B	C	C1	D	W	P	M	K	F	TxL	Weight kg/ib	Kv/Cv	
DN200	mm	201.0	660.0	330.0	312.0	263.0	409.0	420.0	72.0	76.50	20.0	F25	254.0	18x25	412	7742
8"	inch	7.91	25.98	12.99	12.28	10.35	16.10	16.54	2.83	3.01	0.79		10.0	(8 holes)	908	8950
DN250	mm	252.0	787.0	400.0	374.0	310.0	471.0	510.0	72.0	76.50	20.0	F25	254.0	18x25	665	12543
10"	inch	9.92	30.98	15.75	14.72	12.20	18.54	20.08	2.83	3.01	0.79		10.0	(8 holes)	1466	14500
DN300	mm	303.0	838.0	419.0	402.0	344.0	499.0	560.0	72.0	76.50	20.0	F25	254.0	18x35	804	19809
12"	inch	11.93	32.99	16.50	15.83	13.54	19.65	22.05	2.83	3.01	0.79		10.0	(8 holes)	1772	22900

Z81Z**Z81W****Z82Z****Z82W****Z83Z****Z83W**

2"-6" | DN50-DN150 | CLASS 150/300

High Temperature Trunnion Ball

2 Piece Up to 327°C (620°F)

W 200°C (400°F) | **Z** 327°C (620°F)

Components & Materials

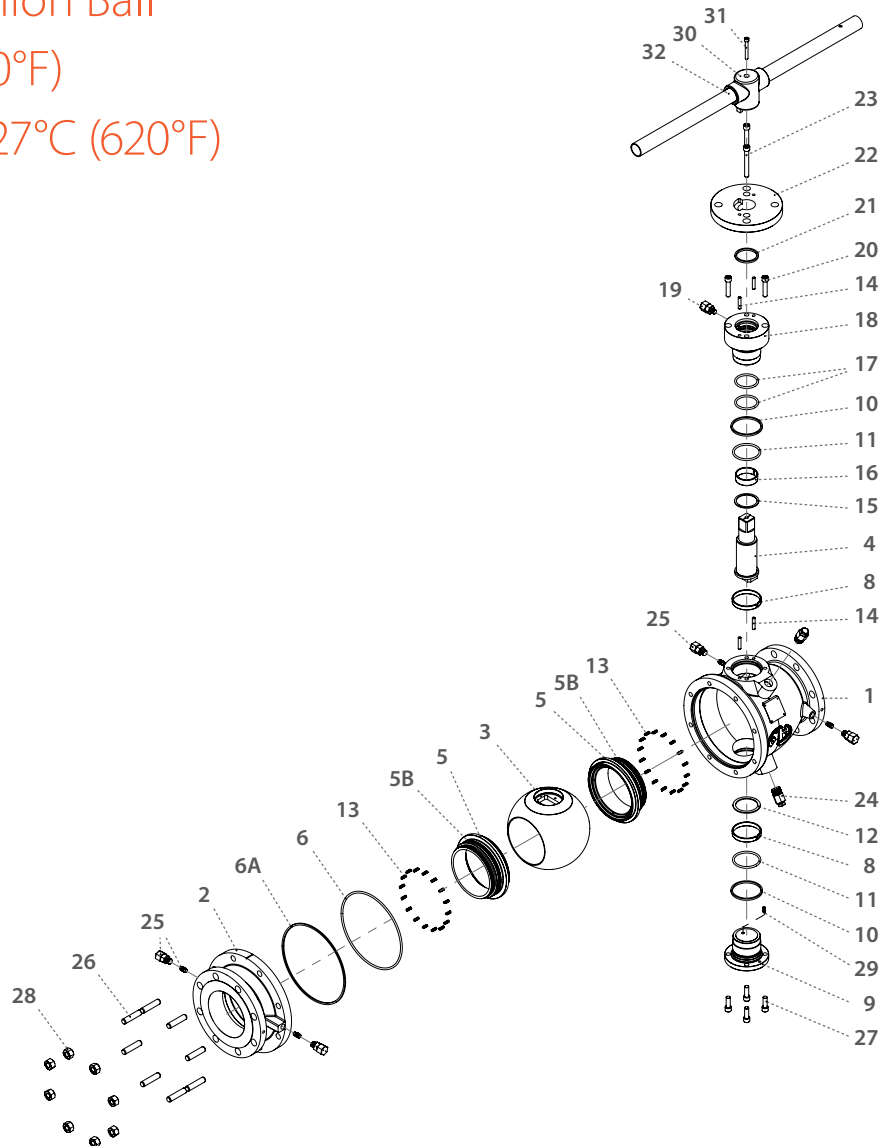

Item	Description	Material Spec. ASTM	Qty.
1	Body	Acc. Ordering code	1
2	Ends	Acc. Ordering code	1
3	Ball	Acc. Ordering code	1
4	Stem	Acc. Ordering code	1
5*	Seat	Acc. Ordering code	2
5B*	Seat Seal	Viton / HNBR	2-4
6*	Body Inner Seal	Viton / HNBR	1
6A*	Body Outer Seal	Graphite	1
8*	Ball Bearing	S.steel 316 + PTFE	2
9	External Trunnion	S.steel / C.steel	1
10*	Gland Plate & External Trunnion Fire Safe Seal	Graphite	2
11*	Gland Plate & External Trunnion Seal	Viton / HNBR	2
12*	Lower Thrust Washer	S.steel 316 + PTFE	1
13	Seat Spring	Inconel X750	28-40
14	Gland Pin	S.steel / C.steel	4
15*	Stem Thrust Washer	S.steel 316 + PTFE	1
16*	Gland Plate Bearing	S.steel 316 + PTFE	1

Item	Description	Material Spec. ASTM	Qty.
17*	Stem Seal	Viton / HNBR	2
18	Gland Plate	S.steel / C.steel	1
19	Stem Grease Fitting	S.steel	1
20	Lower Gland Bolts	A193-B8M / A320 L7	4
21*	Stem Fire Safe Seal	Graphite	1
22	Iso Plate	S.steel / C.steel	1
23	Upper Gland Bolts	A193-B8M / A320 L7	4
24	Plug Valve	S.steel	2
25**	Seat Grease Fitting + Check Valve	S.steel	4
26	Body Studs	A193-B8M / A320 L7	8-12
27	External Trunnion Bolts	A193-B8M / A320 L7	4
28	Body Nuts	A194-8M / A194 L7	8-12
29	Antistatic Spring	Inconel X750	1
30	Wrench Head	S.steel / C.steel	1
31	Wrench Bolt	S.steel / C.steel	1
32	Pipe Handle	S.steel / C.steel Zink plate	1

* Maintenance kit components

** Available from 6" size only

Z81Z**Z81W****Z82Z****Z82W****Z83Z****Z83W**

8"-12" | DN200-DN300 | CLASS 150/300

High Temperature Trunnion Ball

2 Piece Up to 327°C (620°F)

W 200°C (400°F) | **Z** 327°C (620°F)

Components & Materials

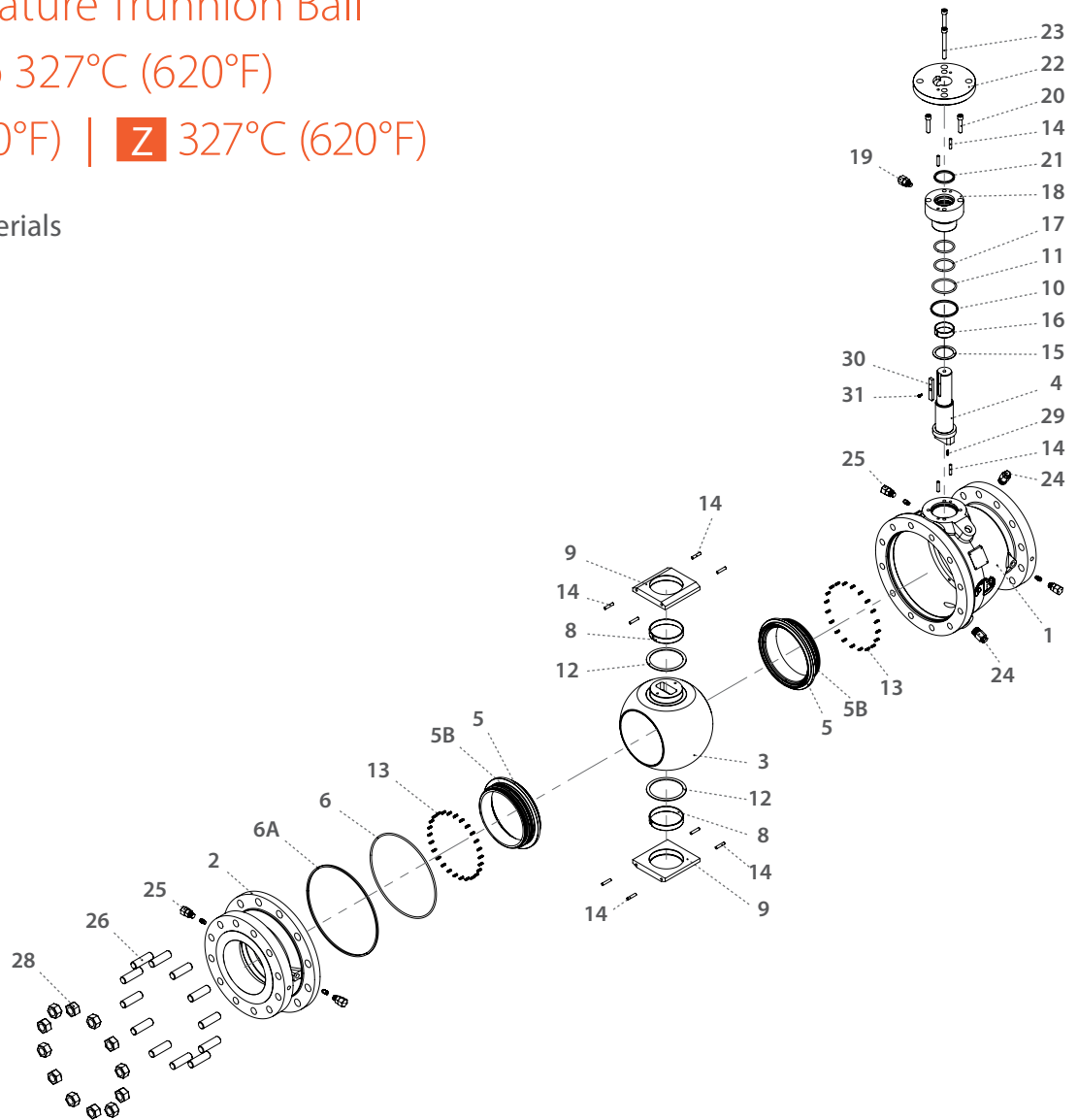

Item	Description	Material Spec. ASTM	Qty.
1	Body	Acc. Ordering code	1
2	Ends	Acc. Ordering code	1
3	Ball	Acc. Ordering code	1
4	Stem	Acc. Ordering code	1
5*	Seat	Acc. Ordering code	2
5B*	Seat Seal	Viton / HNBR	2
6*	Body Inner Seal	Viton / HNBR	2
6A*	Body Outer Seal	Graphite	2
8*	Ball Bearing	S.steel 316 + PTFE	2
9	Trunnion Plate	S.steel / C.steel	2
10*	Gland Plate & External Trunnion Fire Safe Seal	Graphite	1
11*	Gland Plate & External Trunnion Seal	Viton / HNBR	1
12*	Ball Thrust Washer	S.steel 316 + PTFE	2
13	Seat Spring	Inconel X750	52-60
14	Gland Pin	S.steel / C.steel	12
15*	Stem Thrust Washer	S.steel 316 + PTFE	1

Item	Description	Material Spec. ASTM	Qty.
16*	Stem Bearing	S.steel 316 + PTFE	1
17*	Stem Seal	Viton / HNBR	2
18	Gland Plate	S.steel / C.steel	1
19	Stem Grease Fitting	S.steel	1
20	Lower Gland Bolts	A193-B8M / A320 L7	6
21*	Stem Fire Safe Seal	Graphite	1
22	Iso Plate	S.steel / C.steel	1
23	Upper Gland Bolts	A193-B8M / A320 L7	6
24	Plug Valve	S.steel	2
25	Seat Grease Fitting + Check Valve"	S.steel	4
26	Body Studs	A193-B8M / A320 L7	8-16
28	Body Nuts	A194-8M / A194 L7	8-16
29	Antistatic Spring	Inconel X750	1
30	Stem Key	S.steel / C.steel	1
31	Stem Key Bolt	S.steel / C.steel	1

* Maintenance kit components

Z81Q**Z82Q**

2"-6" | DN50-DN150 | CLASS 150/300

High Temperature Trunnion Ball 2 Piece Up to 538°C (1000°F)

Valve Dimensions

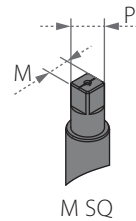
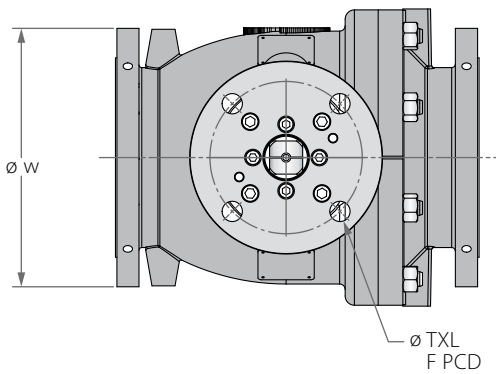
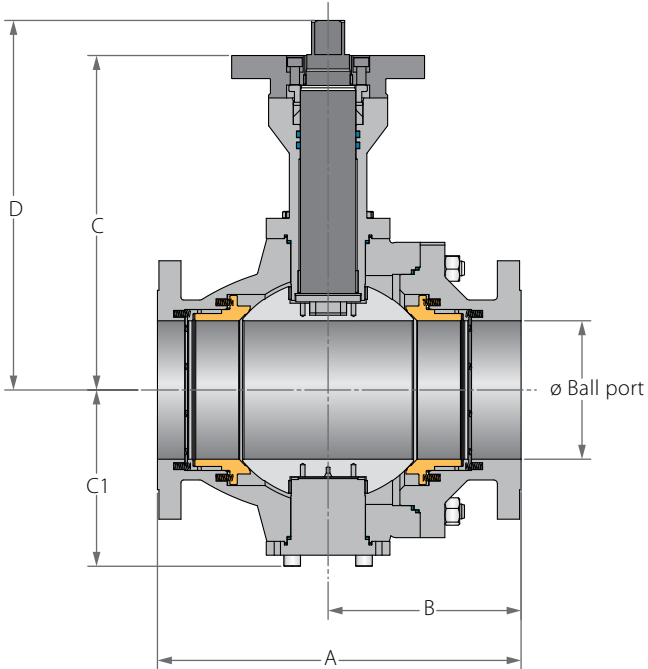

Full port	Unit	Ball port	A		B		C	C1	D	W		M SQ	P SQ	F	TxL	Weight kg/ib		Kv/Cv		
			150	300	150	300				150	300					150	300	150	300	
DN50	mm	49.0	178.0	216.0	89.0	113.50	250.0	94.0	269.0	150.0	165.0	16.90	21.30	F10	102.0	M10X15	22	25	400	363
2"	inch	1.93	7.01	8.50	3.50	4.47	9.84	3.70	10.59	5.91	6.50	0.67	0.84		4.02	(4 holes)	49	55	463	420
DN80	mm	74.0	203.0	283.0	101.50	154.0	277.0	117.0	301.0	190.0	210.0	21.90	26.90	F12	125.0	M12X15	40	51	1125	952
3"	inch	2.91	7.99	11.14	4.0	6.06	10.91	4.61	11.85	7.48	8.27	0.86	1.06		4.92	(4 holes)	88	112	1300	1100
DN100	mm	100.0	229.0	305.0	114.50	164.50	293.0	139.0	322.0	230.0	255.0	26.90	34.90	F14	140.0	M16X15	61	73	2154	1860
4"	inch	3.94	9.02	12.0	4.51	6.48	11.54	5.47	12.68	9.06	10.04	1.06	1.37		5.51	(4 holes)	134	161	2490	2150
DN150	mm	150.0	394.0	403.0	209.10	207.60	362.0	191.0	400.0	280.0	320.0	35.90	46.20	F16	165.0	M22X25	133	145	4723	4628
6"	inch	5.91	15.51	15.87	8.23	8.17	14.25	7.52	15.75	11.02	12.60	1.41	1.82		6.50	(4 holes)	293	320	5460	5350

Z81Q**Z82Q**

8"-12" | DN200-DN300 | CLASS 150/300



High Temperature Trunnion Ball 2 Piece Up to 538°C (1000°F)

Valve Dimensions

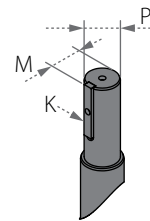
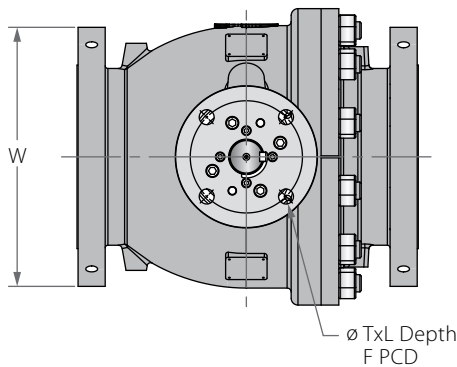
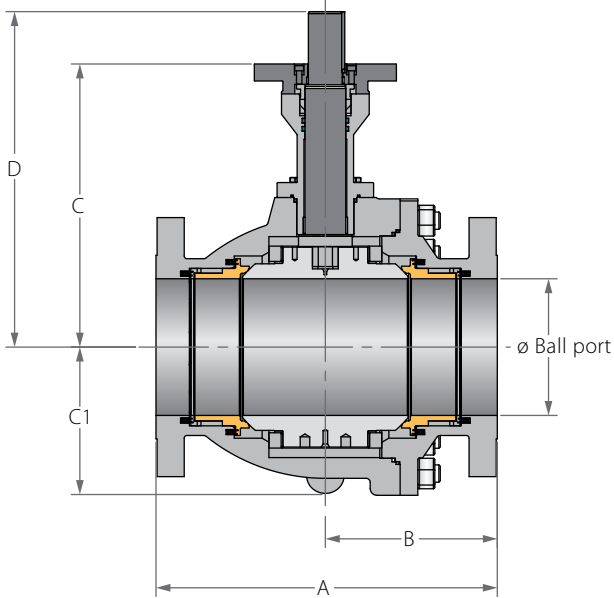

Full port	Unit	Ball port	A		B		C	C1	D	W		P	M	K	F	TxL	Weight kg/ib		Kv/Cv		
			150	300	150	300				150	300						150	300	150	300	
DN200	mm	201.0	457.0	502.0	228.50	253.0	416.0	215.0	493.0	345.0	380.0	50.0	54.0	14.0	F16	165.0	22x25	250	288	9273	8737
8"	inch	7.91	17.99	19.76	9.0	9.96	16.38	8.46	19.41	13.58	14.96	1.97	2.13	0.55		6.50	(4 holes)	551	635	10720	10100
DN250	mm	252.0	533.0	568.0	270.0	287.50	504.0	260.0	581.0	405.0	445.0	50.0	54.0	14.0	F25	254.0	18x25	405	475	15224	14792
10"	inch	9.92	20.98	22.36	10.63	11.32	19.84	10.24	22.87	15.94	17.52	1.97	2.13	0.55		10.0	(8 holes)	893	1047	17600	17100
DN300	mm	303.0	610.0	648.0	298.0	313.0	590.0	300.0	671.0	485.0	520.0	60.0	63.50	18.0	F25	254.0	18x25	595	672	23096	22404
12"	inch	11.93	24.02	25.51	11.73	12.32	23.23	11.81	26.42	19.09	20.47	2.36	2.50	0.71		10.0	(8 holes)	1312	1481	26700	25900

Z83Q 2"-6" | DN50-DN150 | CLASS 600

High Temperature Trunnion Ball 2 Piece Up to 538°C (1000°F)

Valve Dimensions

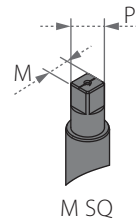
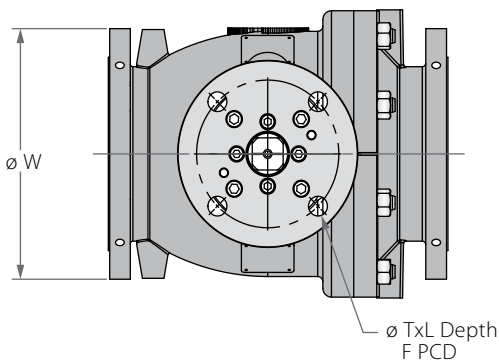
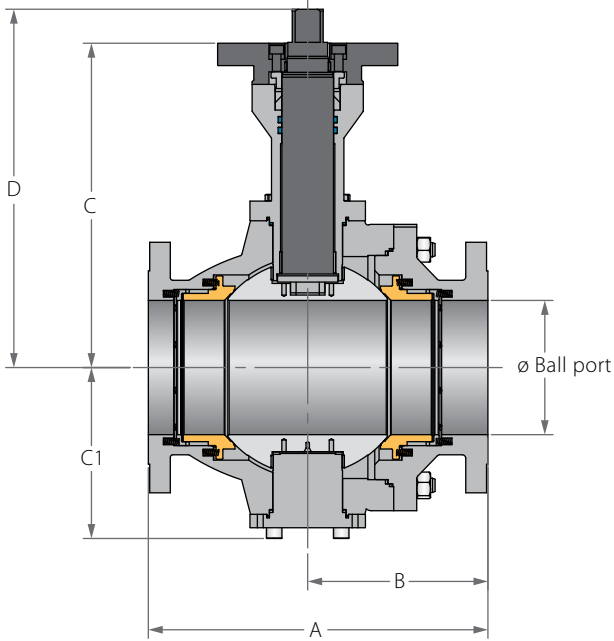

Full port	Unit	Ball port	A	B	C	C1	D	W	M SQ	P SQ	F	TxL	Weight kg/ib	Kv/Cv	
DN50	mm	49.0	292.0	131.0	272.0	119.0	291.0	165.0	16.90	21.30	F12	125.0	M12X15 (4 holes)	41	329
2"	inch	1.93	11.50	5.16	10.71	4.69	11.46	6.50	0.67	0.84		4.92		90	380
DN80	mm	74.0	356.0	161.0	306.0	160.0	330.0	210.0	21.90	26.90	F12	125.0	M12X15 (4 holes)	76	874
3"	inch	2.91	14.02	6.34	12.05	6.30	12.99	8.27	0.86	1.06		4.92		168	1010
DN100	mm	100.0	432.0	216.0	334.0	184.0	364.0	275.0	26.90	34.90	F16	165.0	M22X25 (4 holes)	132	1557
4"	inch	3.94	17.01	8.50	13.15	7.24	14.33	10.83	1.06	1.37		6.50		291	1800
DN150	mm	150.0	559.0	278.0	386.0	220.0	424.0	355.0	35.90	46.20	F16	165.0	M22X25 (4 holes)	340	3893
6"	inch	5.91	22.01	10.94	15.20	8.66	16.69	13.98	1.41	1.82		6.50		750	4500



High Temperature Trunnion Ball 2 Piece Up to 538°C (1000°F)

Valve Dimensions

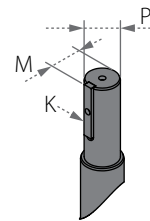
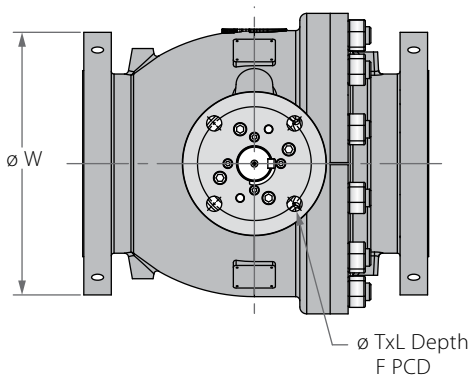
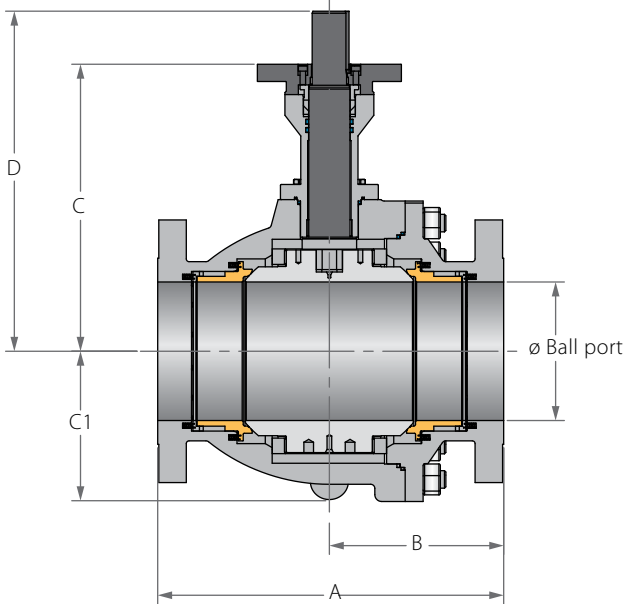

Full port	Unit	Ball port	A	B	C	C1	D	W	P	M	K	F	T x L	Weight kg/ib	Kv/Cv	
DN200	mm	201.0	660.0	330.0	418.0	263.0	515.0	420.0	72.0	76.50	20.0	F25	254.0	18x25	460	7742
8"	inch	7.91	25.98	12.99	16.46	10.35	20.28	16.54	2.83	3.01	0.79		10.0	(8 holes)	1014	8950
DN250	mm	252.0	787.0	400.0	519.0	310.0	616.0	510.0	72.0	76.50	20.0	F30	298.0	22x30	704	12543
10"	inch	9.92	30.98	15.75	20.43	12.20	24.25	20.08	2.83	3.01	0.79		11.73	(8 holes)	1552	14500
DN300	mm	303.0	838.0	419.0	598.0	344.0	695.0	560.0	72.0	76.50	20.0	F30	298.0	22x30	890	19809
12"	inch	11.93	32.99	16.50	23.54	13.54	27.36	22.05	2.83	3.01	0.79		11.73	(8 holes)	1962	22900

Z81Q**Z82Q**

2"-6" | DN50-DN150 | CLASS 150/300

High Temperature Trunnion Ball 2 Piece Up to 538°C (1000°F)

Components & Materials

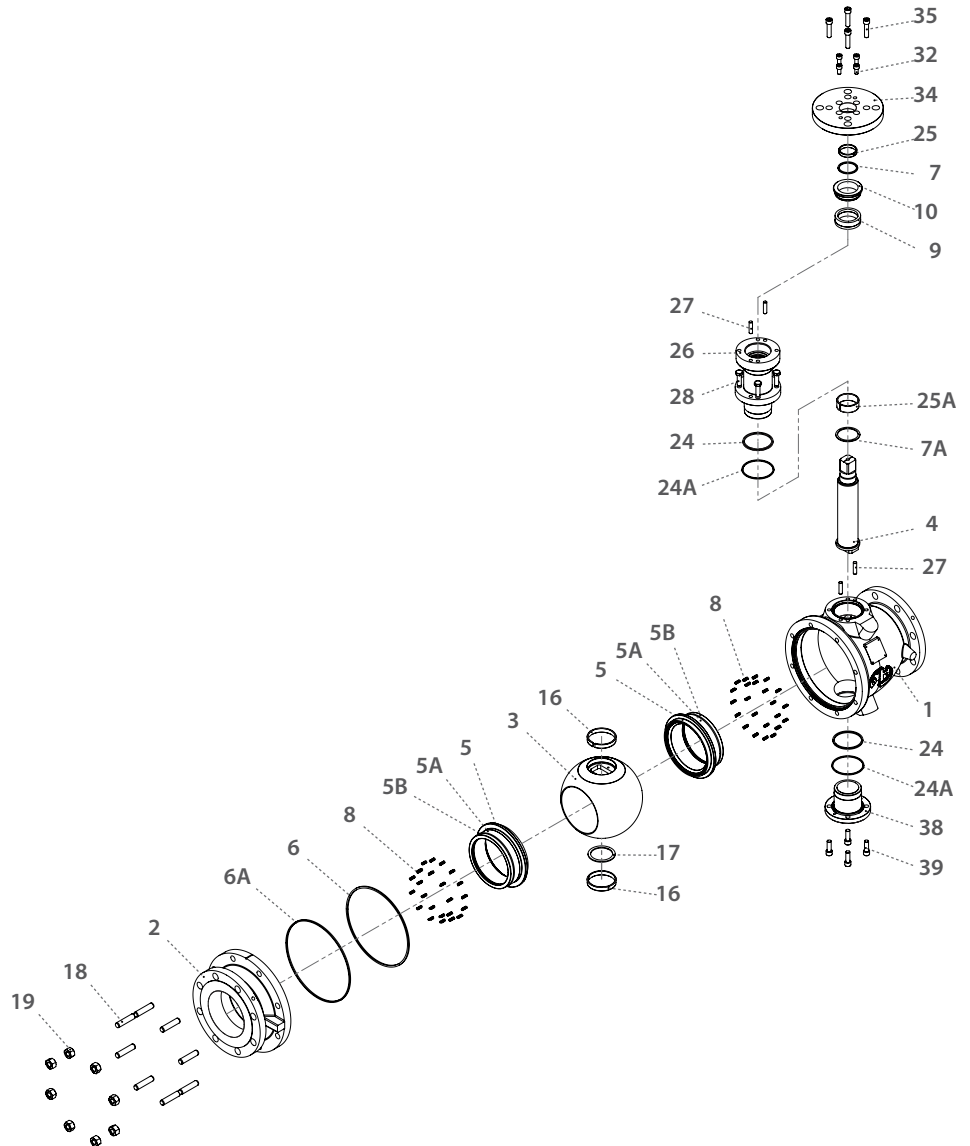

Item	Description	Material Spec. ASTM	Qty.
1	Body	Acc. Ordering Code	1
2	End	Acc. Ordering Code	1
3	Ball	Acc. Ordering Code	1
4	Stem	Acc. Ordering Code	1
5*	Seat	Acc. Ordering Code	2
5A*	Seat Seal	Graphite	2
5B*	Seat Ring	Acc. Ordering Code	2
6*	Body Inner Seal	Graphite	1
6A*	00-91-60-239	Graphite	1
7	Upper Thrust Seal	S.steel 316 / Inconel 625	1
7A	Lower Thrust Seal	S.steel 316 / Inconel 625	1
8	Seat Spring	Inconel X750	16-48
9*	Stem Seal	Graphite	1
10	Follower	S.steel	1
16	Ball Bearing	Inconel 625	2
17	Ball Thrust Seal	Inconel 625	1

Item	Description	Material Spec. ASTM	Qty.
18	Body Stud	A193-B8M / A320 L7	4-12
19	Body Nuts	A194 8M / A194 L7	4-12
24*	Bonnet Inner Seal	Graphite	2
24A*	48G-20-139	Graphite	2
25	Upper Stem Bearing	Inconel 625	1
25A	Lower Stem Bearing	Inconel 625	1
26	Bonnet	S. steel / C. steel	1
27	Bonnet Pin	S. steel / C. steel	4
28	Bonnet Bolts	A193-B8M / A320 L7	4-8
32	Follower Drive Bolts	A193-B8M / A320 L7	4-8
34	Iso Plate	S. steel / C. steel	1
35	Iso Plate Bolts	A193-B8M / A320 L7	4-8
38	External Trunnion	S. steel / C. steel	1
39	External Trunnion Bolts	A193-B8M / A320 L7	4-8

* Maintenance kit components



High Temperature Trunnion Ball 2 Piece Up to 538°C (1000°F)

Components & Materials

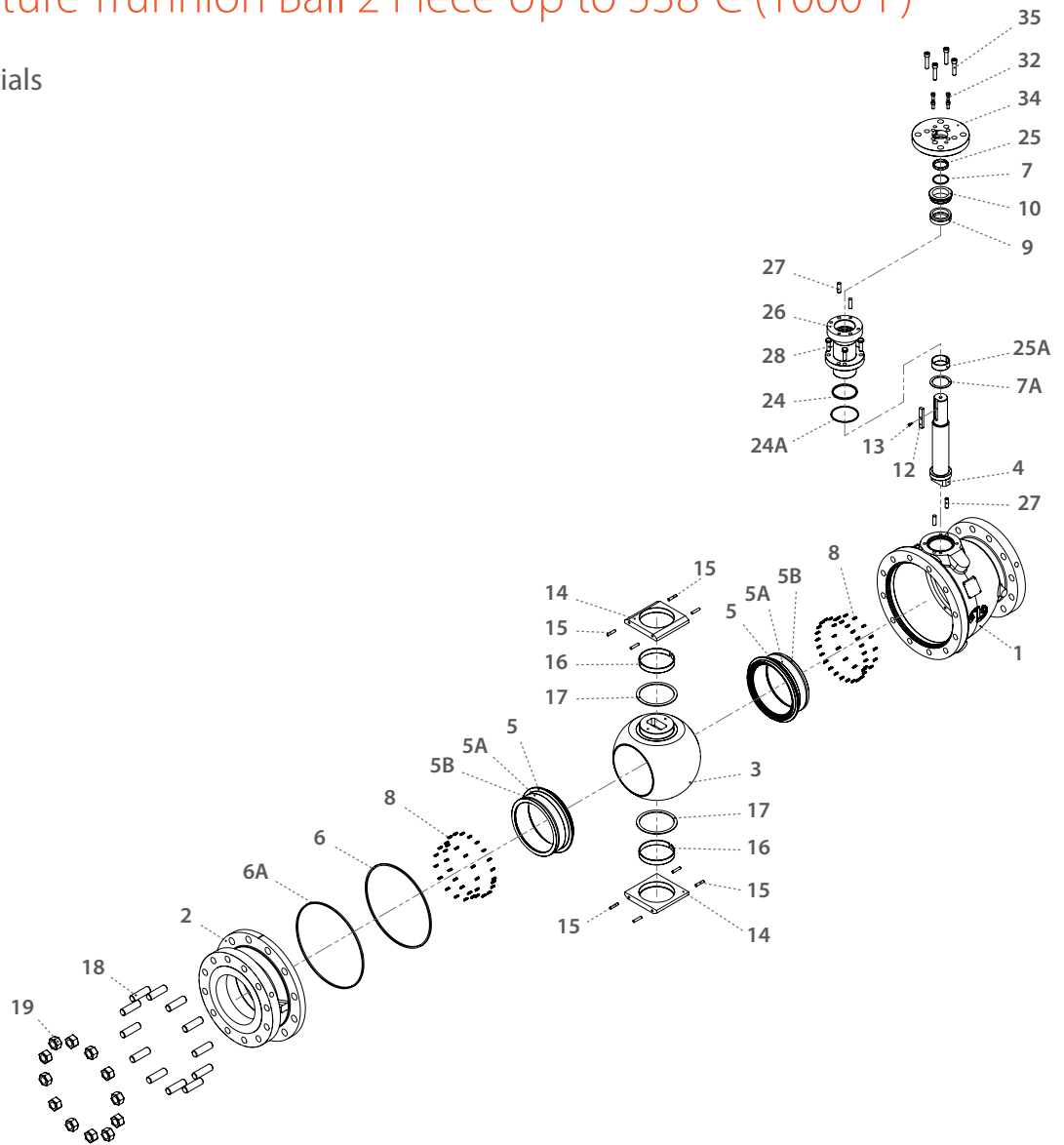

Item	Description	Material Spec. ASTM	Qty.
1	Body	Acc. Ordering code	1
2	End	Acc. Ordering code	1
3	Ball	Acc. Ordering code	1
4	Stem	Acc. Ordering code	1
5*	Seat	Acc. Ordering code	2
5A*	Seat Seal	Graphite	2
5B*	Seat Ring	Acc. Ordering code	2
6*	Body Inner Seal	Graphite	1
6A*	Body Outer Seal	Graphite	1
7	Upper Thrust Seal	S.steel / Inconel 625	1
7A	Lower Thrust Seal	S.steel / Inconel 625	1
8	Seat Spring	Inconel X750	68-76
9*	Stem Seal	Graphite	1
10	Follower	S.steel	1
12	Stem Key	S.steel / C.steel	1
13	Stem Key Bolt	S.steel / C.steel	1
14	Trunnion Plate	S.steel / C.steel	2

Item	Description	Material Spec. ASTM	Qty.
15	Trunnion Plate Pin	S.steel / C.steel	8
16	Ball Bearing	Inconel 625	2
17	Ball Thrust Washer	Inconel 625	2
18	Body Stud	A193-B8M / A320 L7	8-20
19	Body Nuts	A194 8M / A194 L7	8-20
24*	Bonnet Inner Seal	Graphite	1
24A*	Bonnet Outer Seal	Graphite	1
25	Upper Stem Bearing	Inconel 625	1
25A	Lower Stem Bearing	Inconel 625	1
26	Bonnet	S.steel / C.steel	1
27	Bonnet Pin	S.steel / C.steel	4
28	Bonnet Bolts	A193-B8M / A320 L7	4-8
32	Follower Drive Bolts	A193-B8M / A320 L7	4-8
34	Iso Plate	S.steel / C.steel	1
35	Iso Plate Bolts	A193-B8M / A320 L7	4-8

* Maintenance Seals kit components



High Temperature Trunnion Ball 2 Piece - Ordering Code System

"Mandatory option" options are marked with **green background** | "Standard offer" options are marked with **light green background**

1	2	3	4	5	6	7	8	9	10	11	12	13	14	15	16	17	18	19	20	21	22	23	24	...	30
4	0			Z	B	8	1	W	-	6	M	6	D	I	V	G	/	1	5	0					
Size		Features			Series		Design	Body & ends material			Stem material	Ball/Seat material	Seat feature	Hardening	Inner Seal	Outer Seal	End Connection			Special features					

Size (1-2)		
Code	inch	mm
20	2"	50
30	3"	80
40	4"	100
60	6"	150
80	8"	200
A0	10"	250
A2	12"	300

Features (3-6)	
Z	Metal seats
B	Full port

Series - 2 Piece Cast (7-8)	
81	ASME B16.5 #150 Flanged RF
82	ASME B16.5 #300 Flanged RF
83	ASME B16.5 #600 Flanged RF

Design (9)	
W	-46°C to 200°C (-50°F to 400°F)
Z	-46°C to 327°C (-50°F to 620°F)
Q	-60°C to 538°C (-76°F to 1000°F)

Body & ends material (11)	
4*	C. Steel A216 WCB
6	S. Steel A351 CF8M

* Up to 425°C (800°F)

Stem (12)	
M	High Strength S. Steel
Z	Inconel 718

Ball / Seat material (13)	
6	S. Steel A182 316
N*	ASTM A182 F6A (S.Steel 410)

* For O hardening only

Seat feature (14)	
D	Double Piston Effect (DPE) (API 6D DIB-1)
S	Single Piston Effect (SPE) (API 6D DBB)
C	DPE & SPE combination (API 6D DIB-2)

Hardening (15)	
I	Cr3C2- Chromium Carbide with Nickel Chrome binder - HVOF technique
O*	WC-Co- Tungsten Carbide with Cobalt binder HVO technique

* Only with N ball material

Inner Seal (16)	
V	Viton (-20°C to 200°C [-4°F to 400°F])
H	HNBR (-46°C to 150°C [-50°F to 300°F])
K	Kalrez (-20°C to 327°C [-4°F to 620°F])
G	Graphite

Outer Seal (17)	
G	Graphite

End connections (19-22)	
Flanged	
150	ASME B16.5 #150
300	ASME B16.5 #300
600	ASME B16.5 #600

Special features (23-30)	
L*	Seat greasing point
D**	Drain & Vent
Blank	Drain & vent is capped
H**	Drain ball valve & vent
PT***	Basic paint system
PT1	Offshore, Temp Ambient up to 93°C (200°F)
PT2	Offshore, up to 537°C (998°F)

* for 6" and up, not for Q-design

** not for Q-design

*** colors RAL 1018 or 7036
(other colors upon request)

Z47



High Temp. Valves

FLOATING BALL

3 PIECE

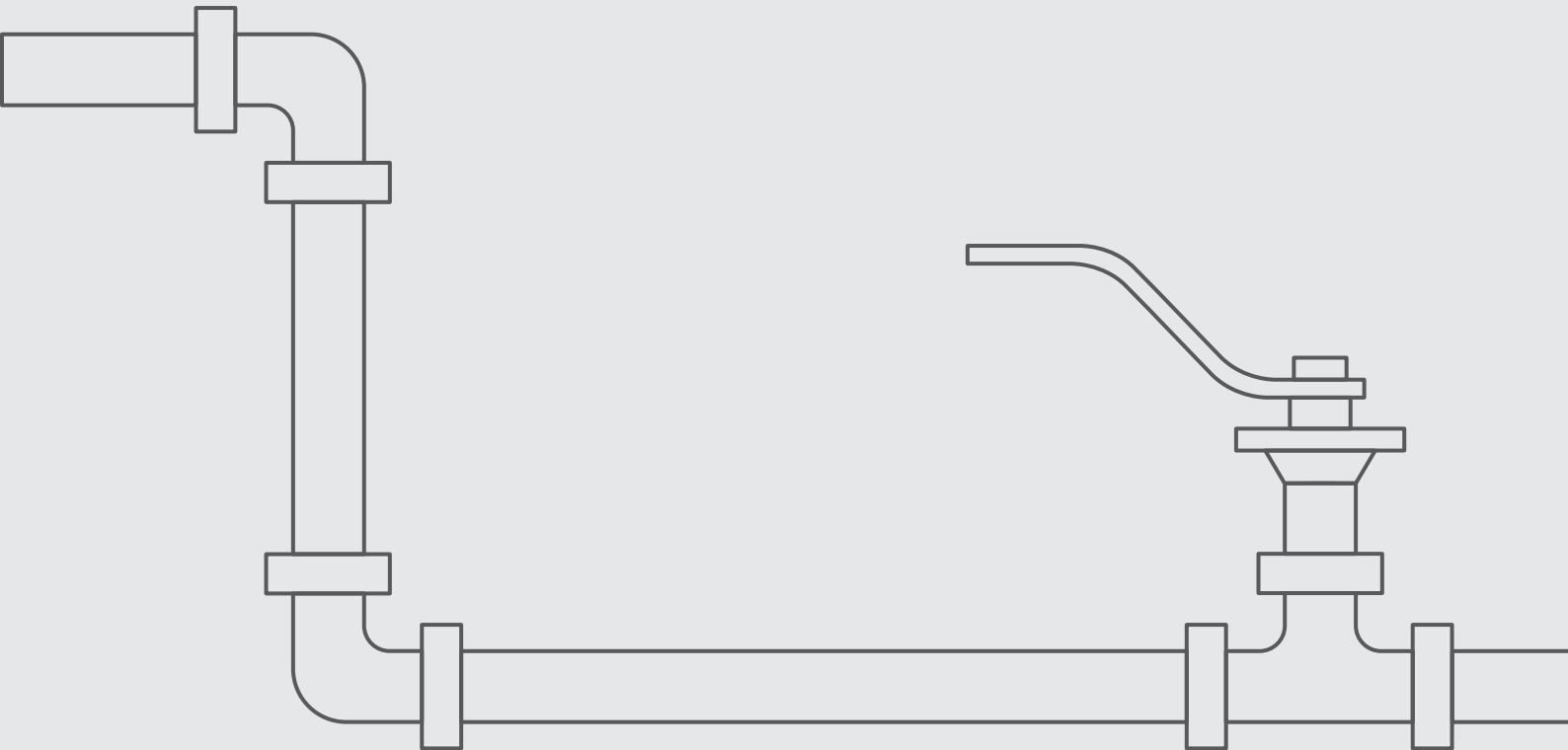

Z47W**Z47Z**

1/2"-1 1/4" | DN15-DN32 | CLASS 600

Floating Ball 3 Piece Up to **W** 260°C (500°F) | **Z** 450°C (842°F)

Valve Dimensions

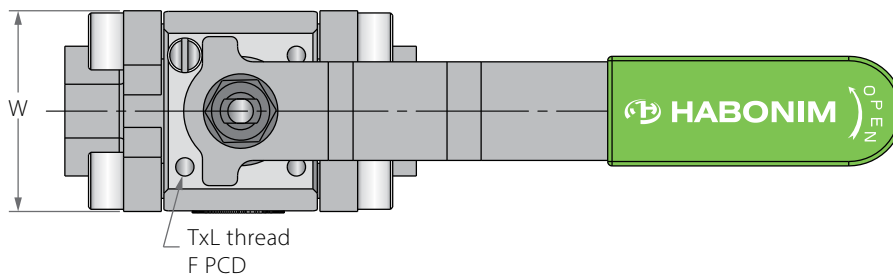
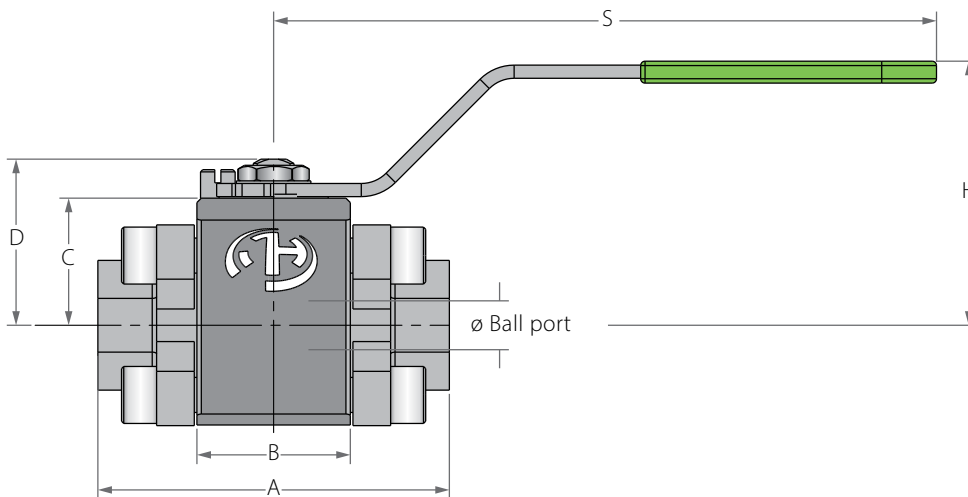

Preparation for actuation

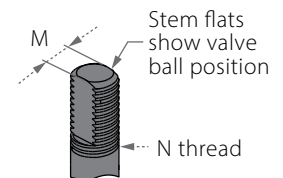
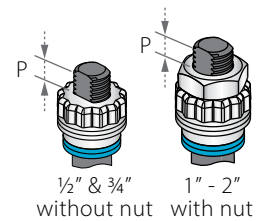

Valve Face To Face sizes are according to Habonim catalog data only, for Extended-weld/Flanged/Tri-clamp end see Face To Face sizes page.

Std. port	Full port	Unit	Ball port	A	B	C	D	H	S	W	M	N	P	F	TxL	Weight kg/lb	Kv Cv	
DN15	DN8, DN10	mm	11.15	80.2	35.0	29.0	37.9	63.0	150.0	45.5	5.5	3/8" UNF	6.65	F03	36.0	M5x6	1.0	7
1/2"	1/4", 3/8"	inch	0.44	3.16	1.38	1.14	1.49	2.48	5.91	1.79	0.22		0.26				1.42	2.26
DN20	DN15	mm	13.0	86.0	40.0	33.5	51.0	76.5	187.0	52.0	7.5	7/16" UNF	6.65	F04	36.0	M5x8	1.5	10
3/4"	1/2"	inch	0.51	3.39	1.57	1.32	2.01	3.01	7.36	2.05	0.30		0.26				1.42	3.27
DN25	DN20	mm	20.6	111.0	49.0	36.5	66.0	90.0	237.0	60.5	8.7	9/16" UNF	6.65	F05	50.0	M5x8	2.5	28
1"	3/4"	inch	0.81	4.37	1.93	1.44	2.60	3.54	9.33	2.38	0.34		0.26				1.97	5.52
DN32	DN25	mm	25.4	116.0	49.0	38.0	67.5	92.5	237.0	69.0	8.7	9/16" UNF	6.65	F05	50.0	M5x9	3.0	49
1 1/4"	1"	inch	1.0	4.57	1.93	1.50	2.66	3.64	9.33	2.72	0.34		0.26				1.97	6.69

Z47W**Z47Z**

1/2"-1 1/4" | DN15-DN32 | CLASS 600



Floating Ball 3 Piece Up to **W** 260°C (500°F) | **Z** 450°C (842°F)

Components & Materials

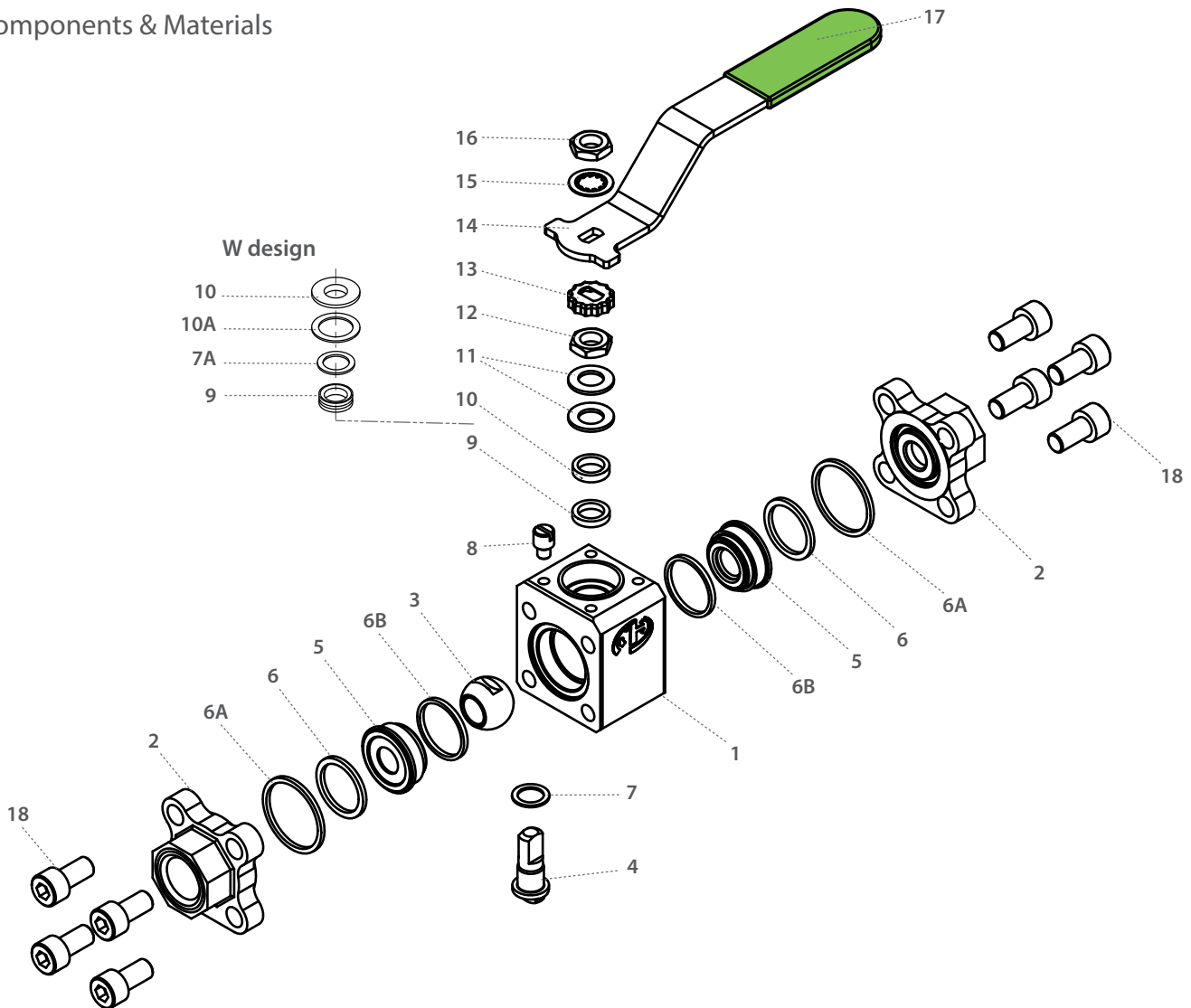

Item	Description	Material specification	Qty.
1	Body	Acc. Ordering Code	1
2	Ends	Acc. Ordering Code	2
3**	Ball	Acc. Ordering Code	1
4	Stem	Acc. Ordering Code	1
5**	Seat Assembly	Acc. Ordering Code	2
6*	Inner Body Seal	Graphite	2
6A*	Outer Body Seal	Graphite	2
6B*	Outer Body Seal	Graphite	2
7*	Stem Thrust Seal	Graphite + Inconel, PEEK	1
7A*	Anti Abrasion Ring	PEEK	1
8	Stop Pin	S. Steel	2
9*	Stem Seal	Graphite ,CF PTFE	1
10	Follower	S. Steel	1
10A*	Slide Bearing	S. Steel	1

Item	Description	Material specification	Qty.
11	Disc Spring	S. Steel	2
12	Stem Nut	S. Steel	1
13	Locking Clip	S. Steel	1
14	Handle	S. Steel	1
15	Serrated Washer	S. Steel	1
16	Handle Nut	S. Steel	1
17	Sleeve	PVC	1
18	Body Bolts	S. Steel	12-16
22	Arrow Flow	S. Steel	1
23	Tag (not shown)	S. Steel	1

* Seals kit components

** Ball and seats kit components

Z47W**Z47Z**

1½"-2½" | DN40-DN65 | CLASS 600

Floating Ball 3 Piece Up to **W** 260°C (500°F) | **Z** 450°C (842°F)

Valve Dimensions

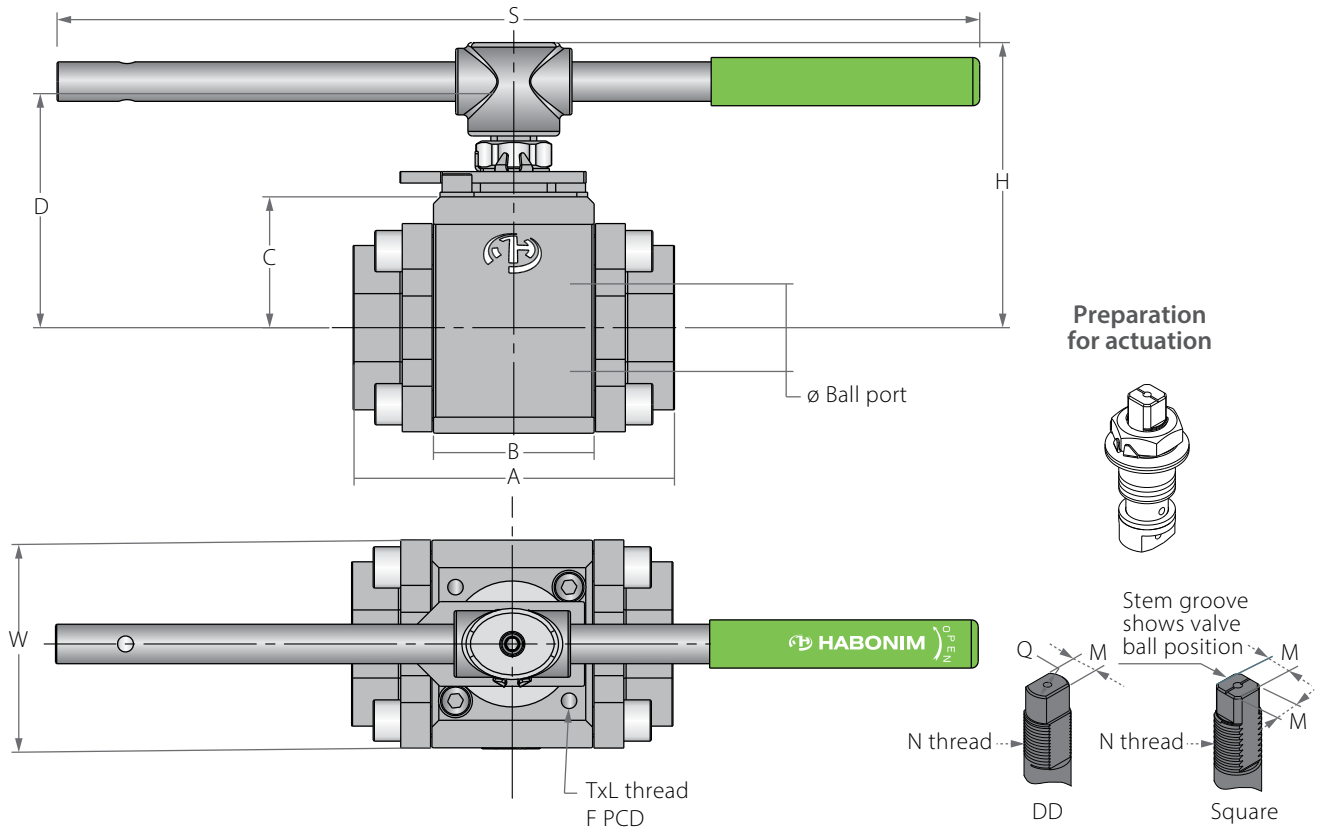

Valve Face To Face sizes are according to Habonim catalog data only, for Extended-weld/Flanged/Tri-clamp end see Face To Face sizes page.

Std. port	Full port	Unit	Ball port	A	B	C	D	H	S	W	M	N	P	F	TxL	Weight kg/lb	Kv Cv	
DN40	DN32	mm	31.8	137.0	70.0	53.0	94.6	120.0	400.0	79.0	13.9	M20x2.5	6.65	F07	70.0	M8X12	5.5	69
1½"	1¼"	inch	1.25	5.39	2.76	2.09	3.72	4.72	15.75	3.11	0.55		0.26		2.76		12.19	80
DN50	DN40	mm	38.1	140.0	70.0	57.0	98.6	124.0	400.0	90.5	13.9	M20x2.5	14.6	F07	70.0	M8X12	6.7	102
2"	1½"	inch	1.50	5.51	2.76	2.24	3.88	4.88	15.75	3.56	0.55		0.57		2.76		14.83	118
DN65	DN50	mm	50.8	179.4	94.0	71.7	118.2	158.5	610.0	108.0	18.9	1"-14	16.7	F10	102.0	M10X16	13.5	208
2½"	2"	inch	2.0	7.06	3.70	2.82	4.65	6.24	24.02	4.25	0.74	UNS-2A	0.66		4.02		29.65	241

Z47W**Z47Z**

1½"-2½" | DN40-DN65 | CLASS 600



Floating Ball 3 Piece Up to **W** 260°C (500°F) | **Z** 450°C (842°F)

Components & Materials

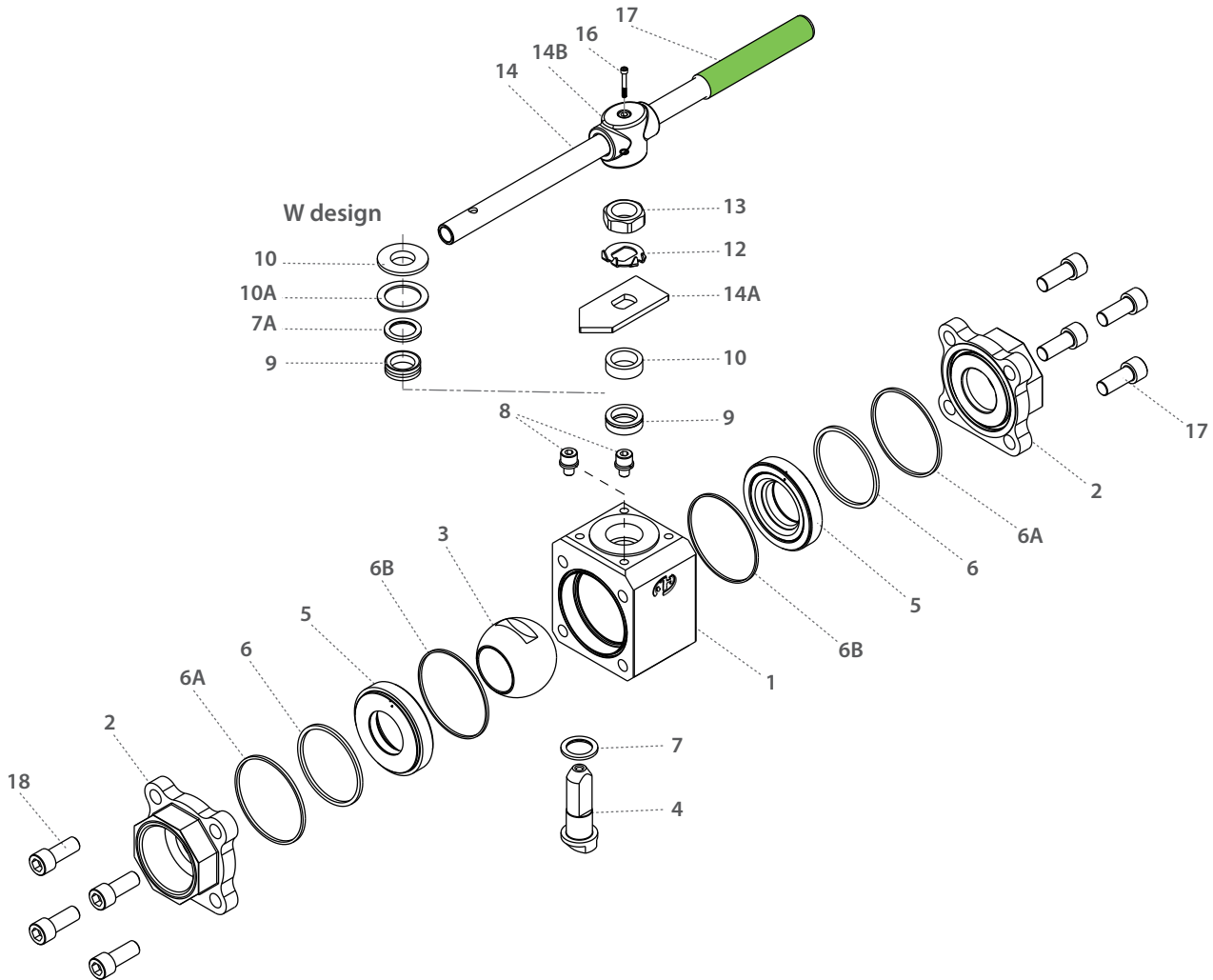

Item	Description	Material specification	Qty.
1	Body	Acc. Ordering Code	1
2	Ends	Acc. Ordering Code	2
3**	Ball	Acc. Ordering Code	1
4	Stem	Acc. Ordering Code	1
5**	Seat Assembly	Acc. Ordering Code	2
6*	Inner Body Seal	Graphite	2
6A*	Outer Body Seal	Graphite	2
6B*	Seat Seal	Graphite	2
7*	Stem Thrust Seal	Graphite + Inconel, PEEK	1
7A*	Anti Abrasion Ring	PEEK	1
8	Stop Pin	S. Steel	2
9*	Stem Seal	Graphite, CF PTFE	1
10	Follower	S. Steel	1
10A*	Slide Bearing	S. Steel	1
12	Stem Nut	S. Steel	1

Item	Description	Material specification	Qty.
13	Tab Lock Washer	S. Steel	1
14	Handle	S. Steel	1
14A	Stop Plate	S. Steel	1
14B	Wrench Head	S. Steel	1
16	Wrench Bolt	S. Steel	1
17	Sleeve	PVC	1
18	Body Bolts	S. Steel	8
23	Tag (not shown)	S. Steel	1
17	Sleeve	PVC	1
18	Body Bolts	S. Steel	20-32
22	Arrow Flow	S. Steel	1
23	Tag (not shown)	S. Steel	1

* Seals kit components

** Ball and seats kit components

Z47W**Z47Z**

3"-6" | DN80-DN150 | CLASS 600

Floating Ball 3 Piece Up to **W** 260°C (500°F) | **Z** 450°C (842°F)

Valve Dimensions

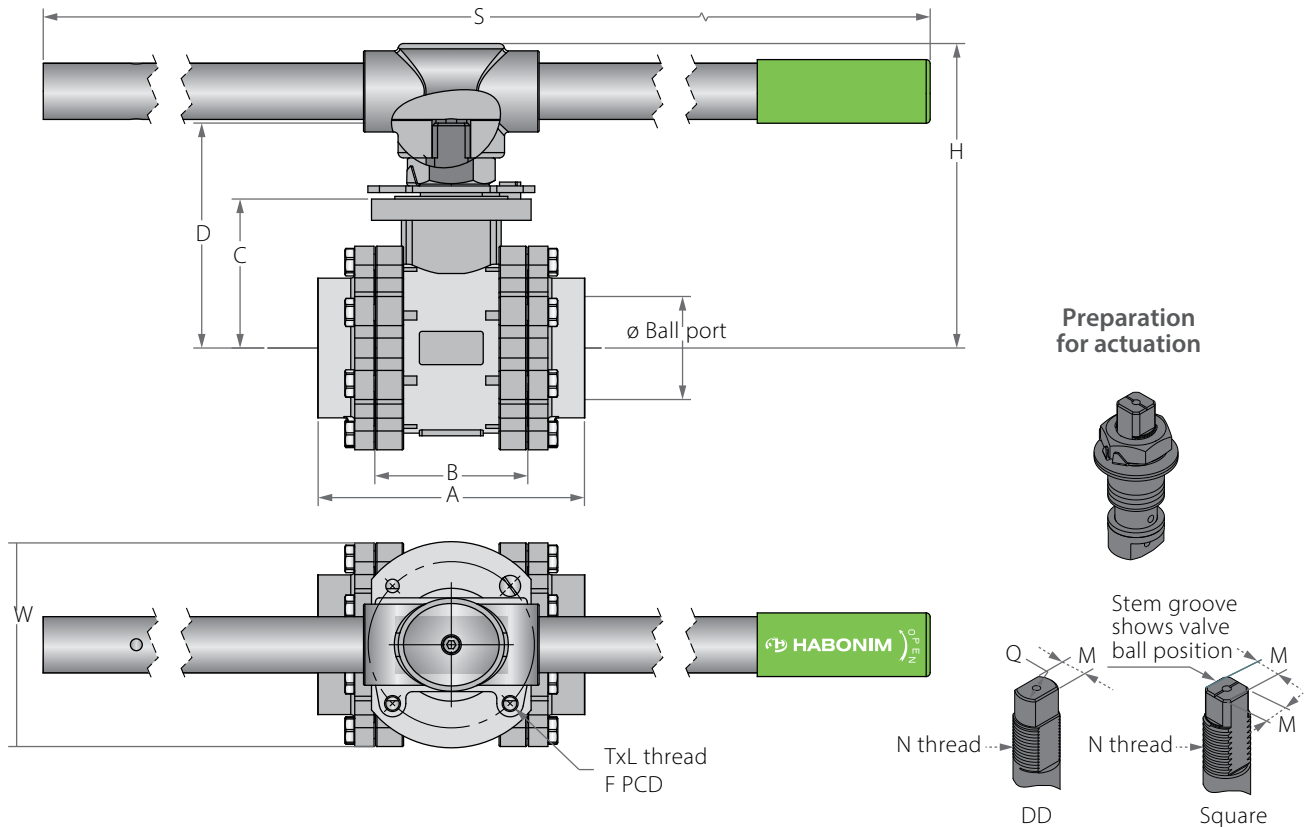

Valve Face To Face sizes are according to Habonim catalog data only, for Extended-weld/Flanged/Tri-clamp end see Face To Face sizes page.

Std. port	Full port	Unit	Ball port	A	B	C	D	H	S	W	M	N	P	F	TxL	Weight kg/lb	Kv Cv
DN80	DN65	mm	63.5	200.8	115.0	98.0	167.5	227.0	916.0	140.0	28.45	1"-14	26.2	125.0	M12X15	25.0	301
3"	2½"	inch	2.50	7.91	4.53	3.86	6.59	8.94	36.06	5.51	1.12	UNS-2A	1.03	4.92	M12X15	55.00	348
DN100	DN80	mm	82.7	234.8	130.0	136.0	205.5	265.0	916.0	177.0	28.45	1"-14	26.2	140.0	M16X20	38.0	616
4"	3"	inch	3.26	9.24	5.12	5.35	8.09	10.43	36.06	6.97	1.12	UNS-2A	1.03	5.51	M16X20	83.60	713
DN150	DN100	mm	100.0	375.0	175.0	157.0	269.6	-	-	217.0	35.9	2"	40.0	165.0	M20X24	60.0	746
6"	4"	inch	3.94	14.76	6.89	6.18	10.61	-	-	8.54	1.41	UN-2A	1.57	6.50	M20X24	132.00	863

Z47W**Z47Z**

3"-6" | DN80-DN150 | CLASS 600



Floating Ball 3 Piece Up to **W** 260°C (500°F) | **Z** 450°C (842°F)

Components & Materials

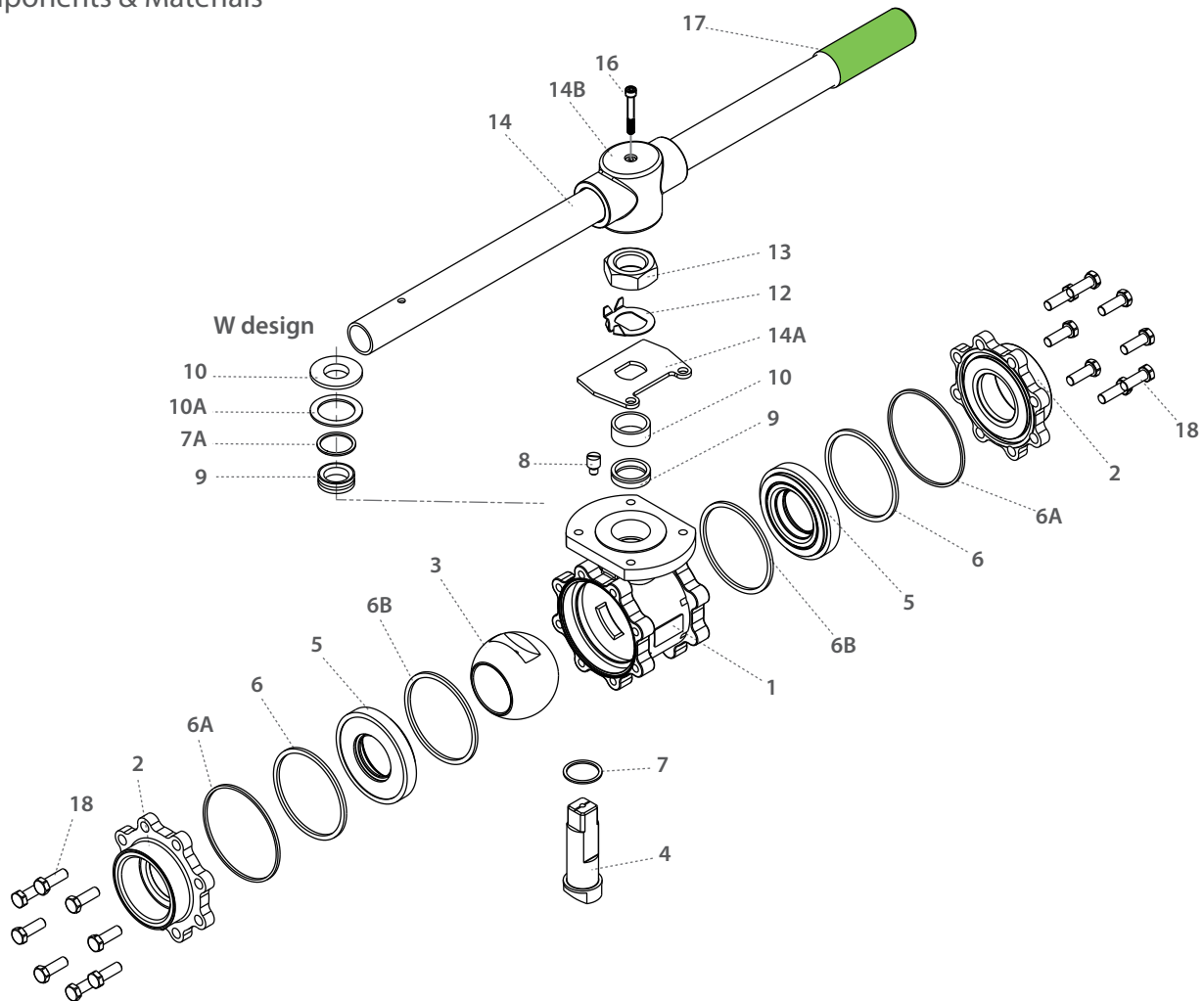

Item	Description	Material specification	Qty.
1	Body	Acc. Ordering Code	1
2	Ends	Acc. Ordering Code	2
3**	Ball	Acc. Ordering Code	1
4	Stem	Acc. Ordering Code	1
5**	Seat Assembly	Acc. Ordering Code	2
6*	Inner Body Seal	Graphite	2
6A*	Outer Body Seal	Graphite	2
6B*	Seat Seal	Graphite	2
7*	Stem Thrust Seal	Graphite + Inconel, PEEK	1
7A*	Anti Abrasion Ring	PEEK	1
8	Stop Pin	S. Steel	1
9*	Stem Seal	Graphite, CF PTFE	1

Item	Description	Material specification	Qty.
10	Follower	S. Steel	1
10A*	Slide Bearing	S. Steel	1
12	Stem Nut	S. Steel	1
13	Tab Lock Washer	S. Steel	1
14	Handle	S. Steel	1
14A	Stop Plate	S. Steel	1
14B	Wrench Head	S. Steel	1
16	Wrench Bolt	S. Steel	1
17	Sleeve	PVC	1
18	Body Bolts	S. Steel	16-24
23	Tag (not shown)	S. Steel	1

* Seals kit components

** Ball and seats kit components



High Temperature - Ordering Code System

"Mandatory option" options are marked with **green background** | "Standard offer" options are marked with **light green background**

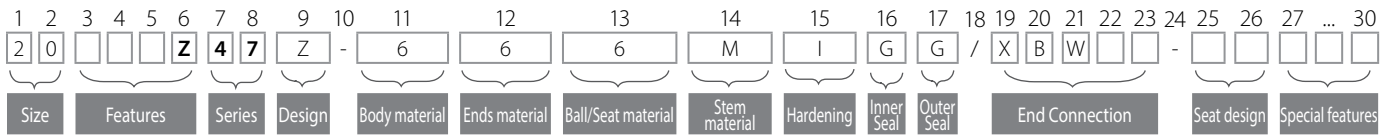

Size (1-2)		
Code	inch	mm
02	¼"	8
03	⅜"	10
05	½"	15
07	¾"	20
10	1"	25
12	1¼"	32
15	1½"	40
20	2"	50
25	2½"	65
30	3"	80
40	4"	100
60	6"	150

Features (3-6)	
Z	Metal seats
B	Full port
N	Control service

Series (7-8)	
Z47	Floating ball 3 piece

Design (9)	
Z	-60°C to 450°C (-76°F to 842°F)
W	-60°C to 260°C (-76°F to 500°F) HermetiX stem seal

Body material (11)	
6	CF8M (316H)
4*	A216 C.st WCB/ A105
F*	LF2

* Up to 425°C (800°F)

Ends material (12)	
6	CF3M / CF8M
4*	A216 C.st WCB/ A105
F*	LF2

* Up to 425°C (800°F)

Ball / Seat material (13) Sizes up to ¾" std. port	
M*	High Strength S. Steel

* ball - XM19, seat - 316

Ball / Seat material (13) Sizes ¾" full bore and up	
6	316
N*	St. Steel 410

* For O hardening only

Stem material (14)	
M	High Strength S. Steel
Z	Inconel 718

Hardening (15)	
I	Cr3C2- Chromium Carbide with Nickel Chrome binder- HVOF technique
O*	WC-Co- Tungsten Carbide with Coblat binder- HVOF technique

* Only with N ball material

Inner Seal (16)	
G	Expanded graphite
B*	NBR
V**	Viton

* Up to 80°C (175°F)
** Up to 120°C (250°F)

Outer Seal (17)	
G	Expanded graphite

End connections (19-23)	
Welded	
XBW	Extended butt weld schd. 40
XSW	Extended socket weld
Threaded	
NPT	ASME B1.20.1 - National Pipe Taper thread
BSPT	EN 10226 - Pipe Taper thread
BSPP	ISO228-1, DIN3852 - Pipe Parallel thread
DIN3852	DIN3852 - Pipe Parallel thread
Flanged	
150	ASME B16.5 #150 RF
300	ASME B16.5 #300 RF
600	ASME B16.5 #600 RF
900	ASME B16.5 #900 RF
PN16	EN1092 PN16 RF
PN40	EN1092 PN40 RF
PN63	EN1092 PN63 RF
PN100	EN1092 PN100 RF
PN160	EN1092 PN160 RF

Seat design (25-26)	
Blank	(New type)

Special Features (27-30)	
B	Body made from rolled bar
Vxx	Characterized control ball xx = angle



Z47Q 1/2"-1 1/4" | DN15-DN32 | CLASS 600

Floating Ball 3 Piece Up to **Q** 650°C (1200°F)

Valve Dimensions

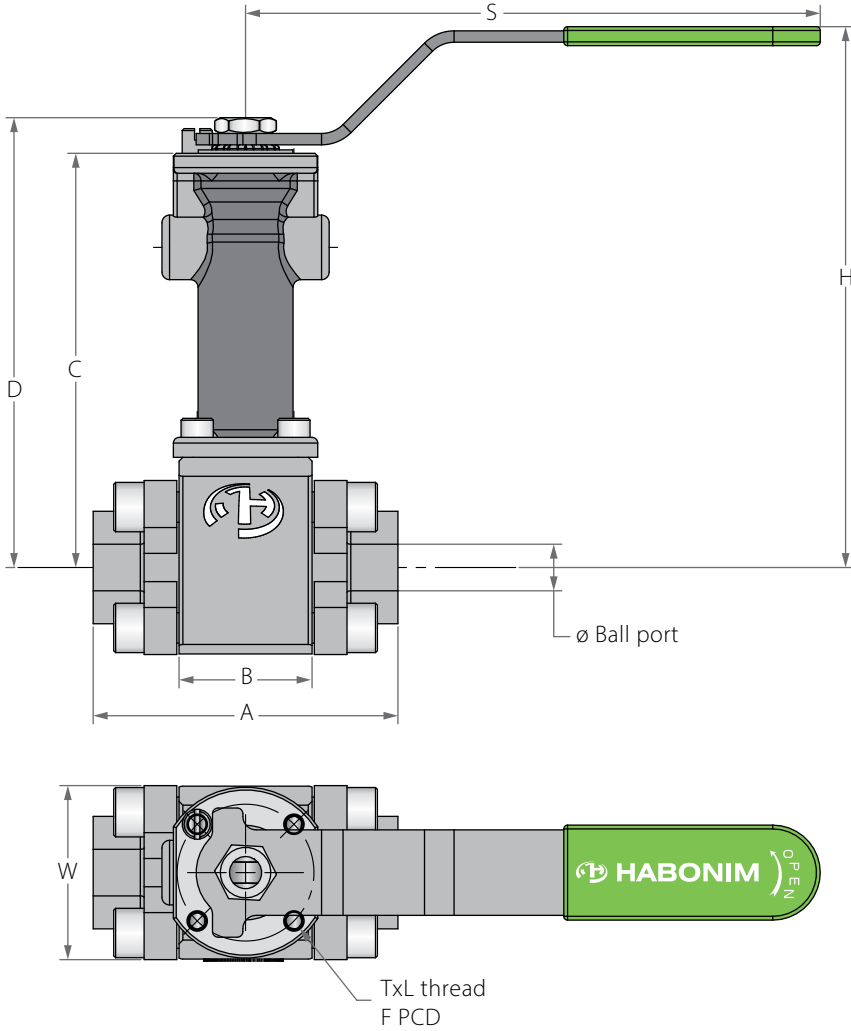

Preparation for actuation

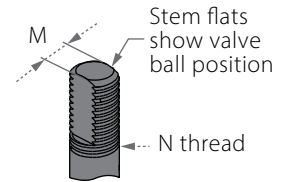
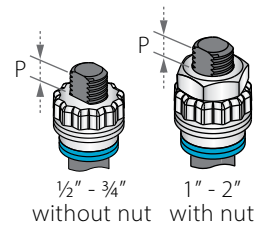

Valve Face To Face sizes are according to Habonim catalog data only, for Extended-weld/Flanged/Tri-clamp end see Face To Face sizes page.

Std. port	Full port	Unit	Ball port	A	B	C	D	H	S	W	M	N	P	F	TxL	Weight kg/lb	Kv Cv	
DN15	DN8, DN10	mm	11.15	80.2	35.0	129.0	137.9	163.0	150.0	45.5	5.5	3/8" UNF	6.65	F03	36.0	M5X6	2.5	7
1/2"	1/4", 3/8"	inch	0.44	3.16	1.38	5.08	5.43	6.42	5.91	1.79	0.22		0.26				1.42	5.51
DN20	DN15	mm	13.0	86.0	40.0	133.5	151.0	176.5	187.0	52.0	7.5	7/16" UNF	6.65	F04	42.0	M5X8	2.5	10
3/4"	1/2"	inch	0.51	3.39	1.57	5.26	5.94	6.95	7.36	2.05	0.30		0.26				1.65	5.51
DN25	DN20	mm	20.6	111.0	49.0	136.5	166.0	190.0	237.0	60.5	8.7	9/16" UNF	6.65	F05	50.0	M6X8	4.5	28
1"	3/4"	inch	0.81	4.37	1.93	5.37	6.54	7.48	9.33	2.38	0.34		0.26				1.97	9.92
DN32	DN25	mm	25.4	116.0	49.0	138.0	167.5	192.5	237.0	69.0	8.7	9/16" UNF	6.65	F05	50.0	M6X9	5.0	49
1 1/4"	1"	inch	1.0	4.57	1.93	5.43	6.59	7.58	9.33	2.72	0.34		0.26				1.97	11.09



Floating Ball 3 Piece Up to **Q** 650°C (1200°F)

Components & Materials

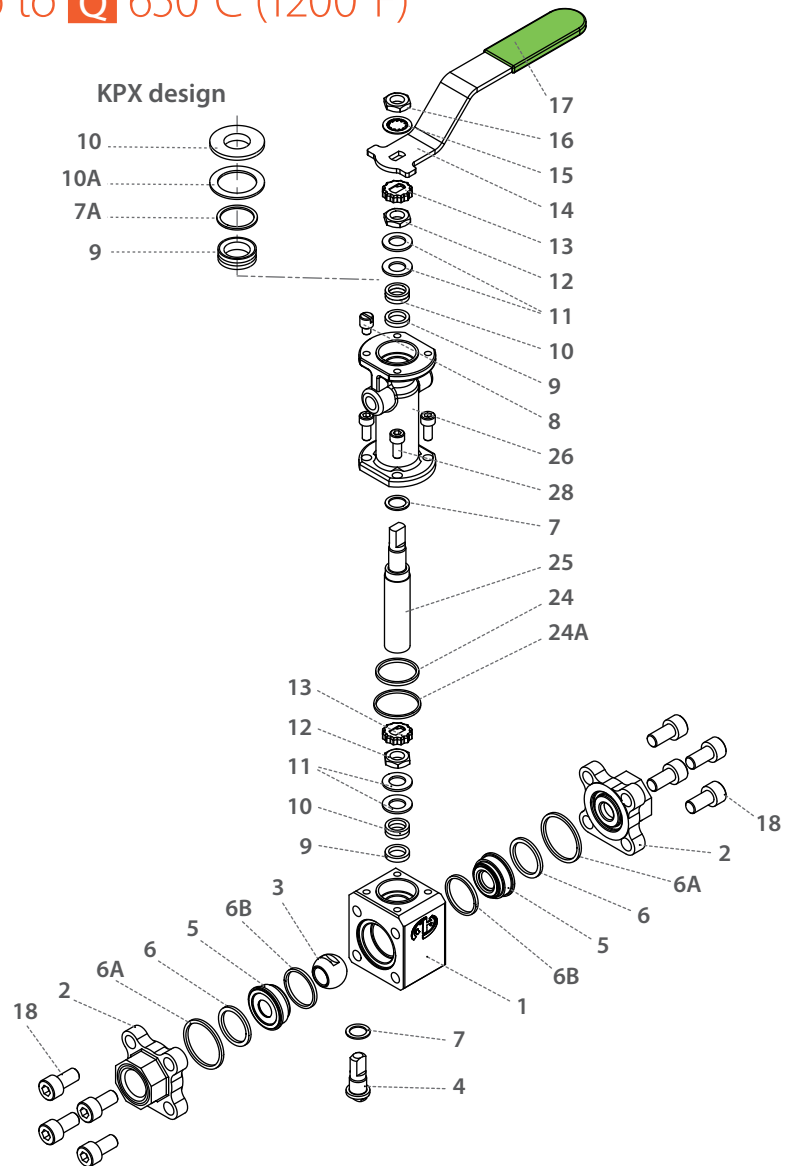

Item	Description	Material specification	Qty.
1	Body	Acc. Ordering Code	1
2	Ends	Acc. Ordering Code	2
3**	Ball	Acc. Ordering Code	1
4	Stem	Acc. Ordering Code	1
5**	Seat Assembly	Acc. Ordering Code	2
6*	Inner Body Seal	Graphite	2
6A*	Outer Body Seal	Graphite	2
6B*	Seat Seal	Graphite	2
7*	Stem Thrust Seal	Graphite + Inconel, PEEK	2
7A*	Anti Abrasion Ring	PEEK	1
8	Stop Pin	S. Steel	1
9*	Stem Seal	Graphite, CF PTFE	2
10	Follower	S. Steel	2
10A*	Slide Bearing	S. Steel	1
11	Disc Spring	S. Steel	4
12	Stem Nut	S. Steel	2

Item	Description	Material specification	Qty.
13	Locking Clip	S. Steel	2
14	Handle	S. Steel	1
15	Serrated Washer	S. Steel	1
16	Handle Nut	S. Steel	1
17	Sleeve	PVC	1
18	Body Bolts	S. Steel	8
23	Tag (not shown)	S. Steel	1
24*	Inner Bonnet Seal	Graphite	1
24A*	Outer Bonnet Seal	Graphite	1
25	Bonnet Stem High Temp	S. Steel	1
26	Bonnet High Temp	S. Steel	1
28	Bonnet Bolts	S. Steel	4

* Seals kit components

** Ball and seats kit components

Z47Q 1½"-2½" | DN40-DN65 | CLASS 600

Floating Ball 3 Piece Up to **Q** 650°C (1200°F)

Valve Dimensions

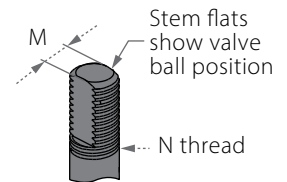
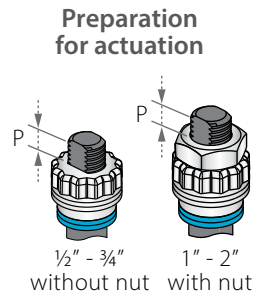
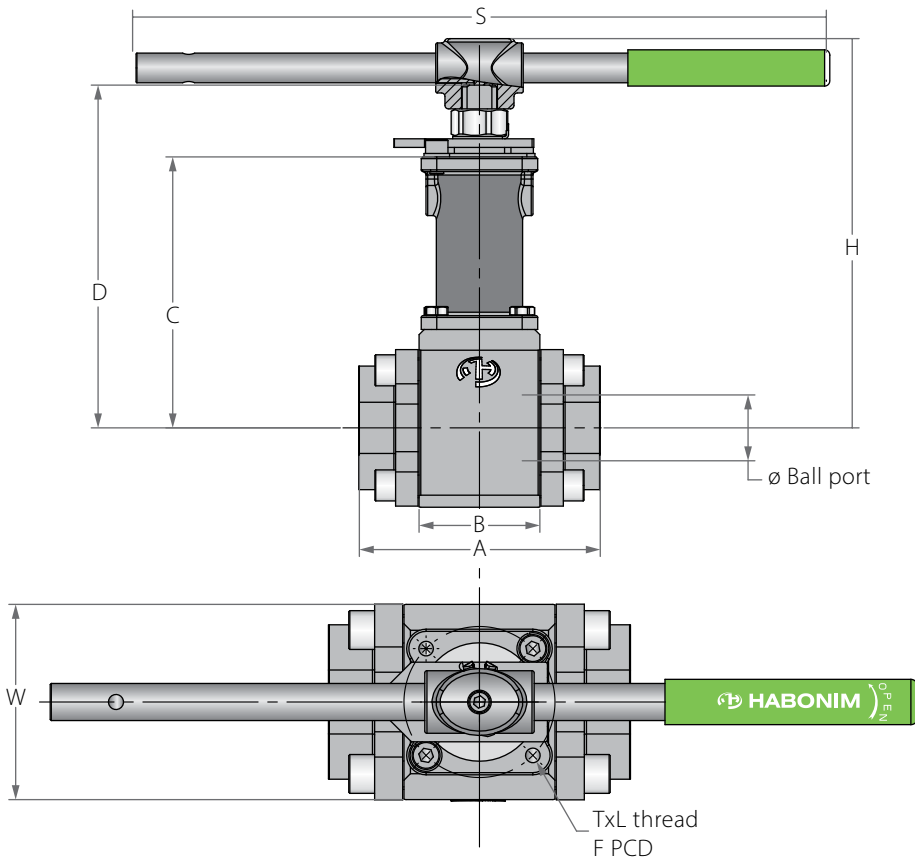

Valve Face To Face sizes are according to Habonim catalog data only, for Extended-weld/Flanged/Tri-clamp end see Face To Face sizes page.

Std. port	Full port	Unit	Ball port	A	B	C	D	H	S	W	M	N	P	F	TxL	Weight kg/lb	Kv Cv
DN40	DN32	mm	31.8	137.0	70.0	153.0	194.6	220.0	400.0	79.0	13.9	M20x2.5	6.65	F07	70.0	8.0	69
1½"	1¼"	inch	1.25	5.39	2.76	6.02	7.66	8.66	15.75	3.11	0.55		0.26		2.76	M8X12	17.69
DN50	DN40	mm	38.1	140.0	70.0	157.0	198.6	224.0	400.0	90.5	13.9	M20x2.5	14.6	F07	70.0	9.2	102
2"	1½"	inch	1.50	5.51	2.76	6.18	7.82	8.82	15.75	3.56	0.55		0.57		2.76	M8X12	20.33
DN65	DN50	mm	50.8	179.4	94.0	221.7	268.2	308.5	610.0	108.0	18.9	1"-14	16.7	F10	102.0	16.5	208
2½"	2"	inch	2.0	7.06	3.70	8.73	10.56	12.14	24.02	4.25	0.74	UNS-2A	0.66		4.02	M10X16	36.25



Floating Ball 3 Piece Up to **Q** 650°C (1200°F)

Components & Materials

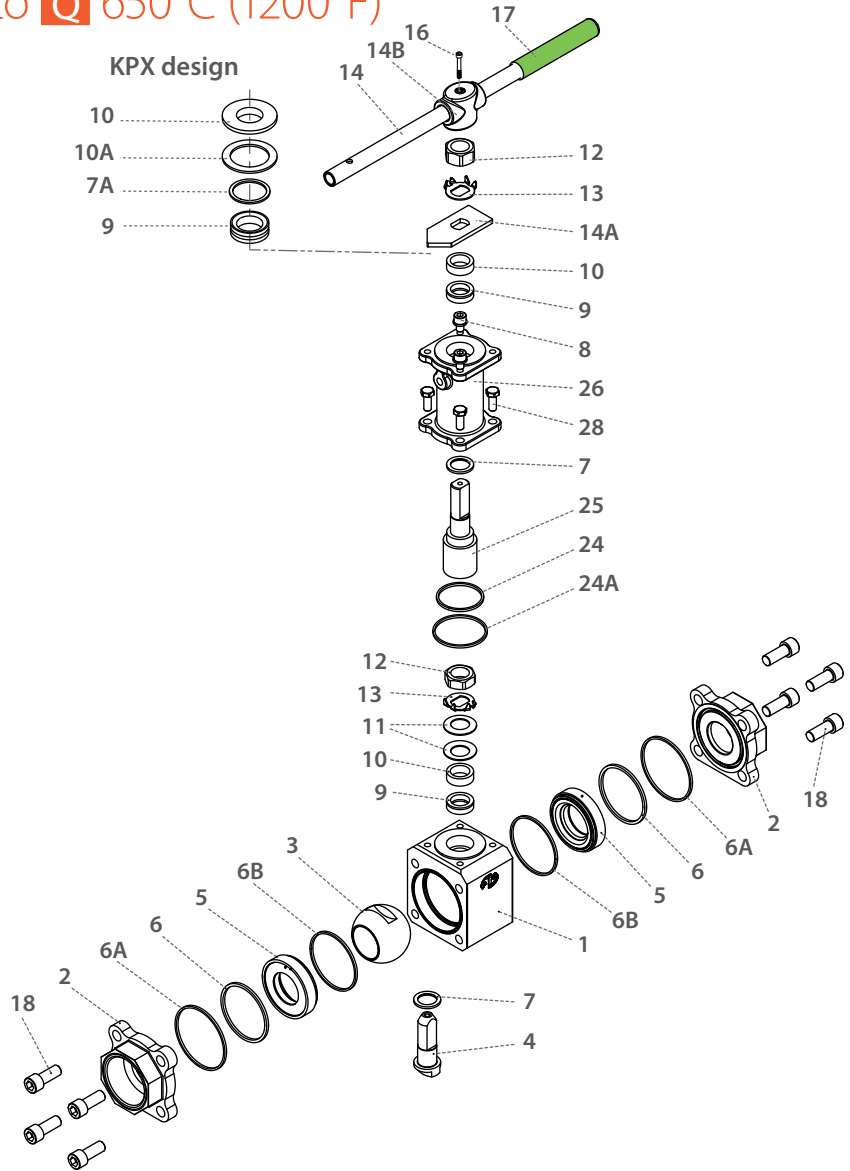

Item	Description	Material specification	Qty.
1	Body	Acc. Ordering Code	1
2	Ends	Acc. Ordering Code	2
3**	Ball	Acc. Ordering Code	1
4	Stem	Acc. Ordering Code	1
5**	Seat Assembly	Acc. Ordering Code	2
6*	Inner Body Seal	Graphite	2
6A*	Outer Body Seal	Graphite	2
6B*	Seat Sea	Graphite	2
7*	Stem Thrust Seal	Graphite + Inconel, PEEK	2
7A*	Anti Abrasion Ring	PEEK	4
8	Stop Pin	S. Steel	1
9*	Stem Seal	Graphite, CF PTFE	2
10	Follower	S. Steel	2
10A*	Slide Bearing	S. Steel	1
11	Disc Spring	S. Steel	4
12	Stem Nut	S. Steel	2

Item	Description	Material specification	Qty.
13	Locking Clip	S. Steel	2
14	Handle	S. Steel	1
15	Serrated Washer	S. Steel	1
16	Wrench Bolt	S. Steel	1
17	Sleeve	PVC	1
18	Body Bolts	S. Steel	8
23	Tag (not shown)	S. Steel	1
24*	Inner Bonnet Seal	Graphite	1
24A*	Outer Bonnet Seal	Graphite	1
25	Bonnet Stem High Temp	S. Steel	1
26	Bonnet High Temp	S. Steel	1
28	Bonnet Bolts	S. Steel	4
28	Bonnet Bolts	S. Steel	4

* Seals kit components

** Ball and seats kit components

Z47Q 3"-6" | DN80-DN150 | CLASS 600

Floating Ball 3 Piece Up to **Q** 650°C (1200°F)

Valve Dimensions

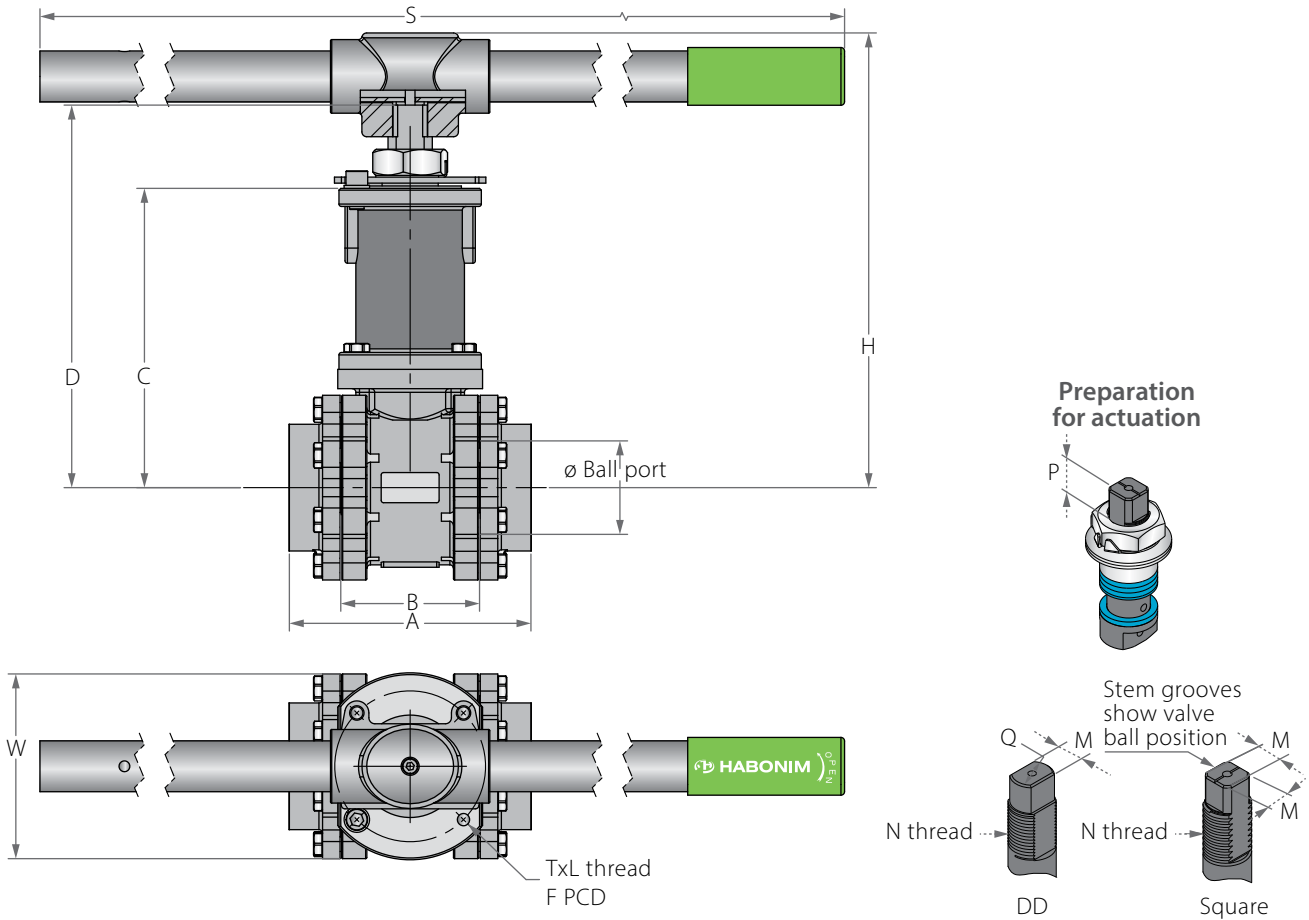

Valve Face To Face sizes are according to Habonim catalog data only, for Extended-weld/Flanged/Tri-clamp end see Face To Face sizes page.

Std. port	Full port	Unit	Ball port	A	B	C	D	H	S	W	M	N	P	F	TxL	Weight kg/lb	Kv Cv
DN80	DN65	mm	63.5	200.8	115.0	248.0	317.5	377.0	916.0	140.0	28.45	1½"-12 UNF-2A	26.2	125.0	M12X15	32.0	301
3"	2½"	inch	2.50	7.91	4.53	9.76	12.50	14.84	36.06	5.51	1.12	UNF-2A	1.03	4.92		70.40	348
DN100	DN80	mm	82.7	234.8	130.0	286.0	355.5	415.0	916.0	177.0	28.45	1½"-12 UNF-2A	26.2	125.0	M12X15	46.0	616
4"	3"	inch	3.26	9.24	5.12	11.26	14.0	16.34	36.06	6.97	1.12	UNF-2A	1.03	4.92		101.20	713
DN150	DN100	mm	100.0	375.0	175.0	307.0	419.6	-	-	217.0	35.9	2"-8 UN-2A	40.0	140.0	M16X20	75.0	746
6"	4"	inch	3.94	14.76	6.89	12.09	16.52	-	-	8.54	1.41	UN-2A	1.57	5.51		165.00	863



Floating Ball 3 Piece Up to **Q** 650°C (1200°F)

Components & Materials

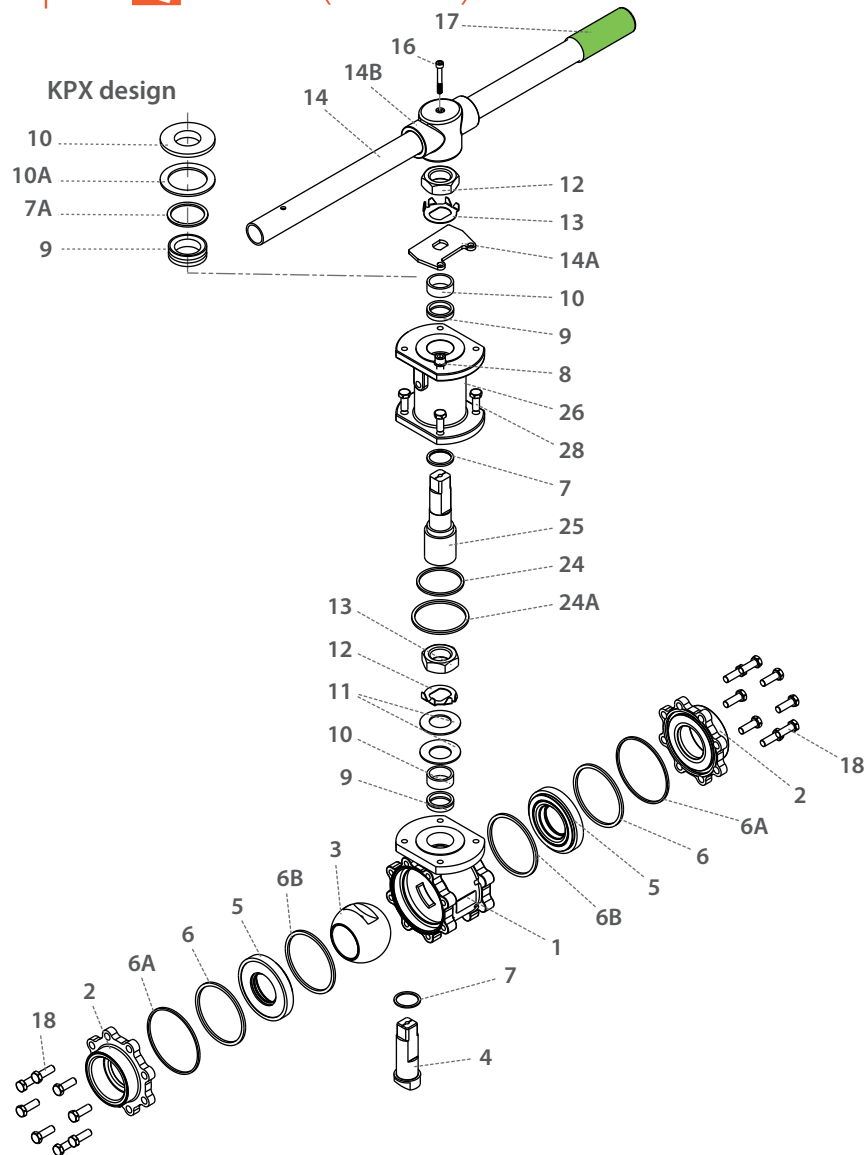

Item	Description	Material specification	Qty.
1	Body	Acc. Ordering Code	1
2	Ends	Acc. Ordering Code	2
3**	Ball	Acc. Ordering Code	1
4	Stem	Acc. Ordering Code	1
5**	Seat Assembly	Acc. Ordering Code	2
6*	Inner Body Seal	Graphite	2
6A*	Outer Body Seal	Graphite	2
6B*	Seat Seal	Graphite	2
7*	Stem Thrust Seal	Graphite + Inconel, PEEK	2
7A*	Anti Abrasion Ring	PEEK	1
8	Stop Pin	S. Steel	1
9*	Stem Seal	Graphite, CF PTFE	2
10A*	Slide Bearing	S. Steel	1
11	Disc Spring	S. Steel	2
12	Stem Nut	S. Steel	2
13	Tab Lock Washer	S. Steel	2

Item	Description	Material specification	Qty.
14	Handle	S. Steel	1
14A	Stop Plate	S. Steel	1
14B	Wrench Head	S. Steel	1
16	Wrench Bolt	S. Steel	1
17	Sleeve	PVC	1
18	Body Bolts	S. Steel	16-24
22	Arrow Flow	S. Steel	1
23	Tag (Not Shown)	S. Steel	1
24*	Inner Bonnet Seal	Graphite	1
24A*	Outer Bonnet Seal	Graphite	1
25	Bonnet Stem High Temp	S. Steel	1
26	Bonnet High Temp	S. Steel	1
28	Bonnet Bolts	S. Steel	4

* Seals kit components

** Ball and seats kit components



High Temperature - Ordering Code System

"Mandatory option" options are marked with **green background** | "Standard offer" options are marked with **light green background**

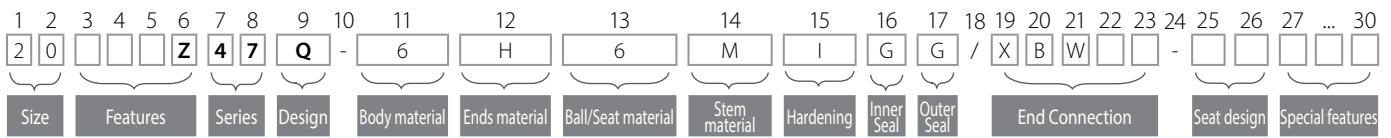

Size (1-2)		
Code	inch	mm
02	¼"	8
03	⅜"	10
05	½"	15
07	¾"	20
10	1"	25
12	1¼"	32
15	1½"	40
20	2"	50
25	2½"	65
30	3"	80
40	4"	100
60	6"	150

Features (3-6)	
Z	Metal seats
B	Full port
N	Control service

Series (7-8)	
Z47	Floating ball 3 piece

Design (9)	
Q	-60°C to 650°C (-76°F to 1200°F)

Body material (11)	
6	CF8M (316H)
J*	F22

Ends material (12)	
H	321H / 316H
J*	F22

* Up to 583°C (1000°F)

Ball / Seat material (13) Sizes up to ¾" std. port	
M*	High Strength S. Steel

* ball - XM19, seat - 316

Ball / Seat material (13) Sizes ¾" full bore and up	
6	316

Stem material (14)	
M	High Strength S. Steel
Z	Inconel 718

Hardening (15)	
I	Cr3C2- Chromium Carbide with Nickel Chrome binder- HVOF technique

Inner Seal (16)	
G	Expanded graphite

Outer Seal (17)	
G	Expanded graphite

End connections (19-23)	
Welded	
XBW	Extended butt weld schd. 40
XSW	Extended socket weld
Threaded	
NPT	ASME B1.20.1 - National Pipe Taper thread
BSPT	EN 10226 - Pipe Taper thread
BSPP	ISO228-1, DIN3852 - Pipe Parallel thread
DIN3852	DIN3852 - Pipe Parallel thread
Flanged	
150*	ASME B16.5 #150 RF
300	ASME B16.5 #300 RF
600	ASME B16.5 #600 RF
900	ASME B16.5 #900 RF
PN16	EN1092 PN16 RF
PN40	EN1092 PN40 RF
PN63	EN1092 PN63 RF
PN100	EN1092 PN100 RF
PN160	EN1092 PN160 RF

* Up to 538°C (1,000°F)

Seat design (25-26)	
Blank	(New type)

Special Features (27-30)	
B	Body made from rolled bar
Vxx	Characterized control ball xx = angle
KPX*	Bonnet top Hermetix

* Up to 550°C (1,022°F)



Face To Face Sizes

Valve Size	B		A-XBW, XSW , ETI, ETD		A-ETO	A-TC	A-Flange Class 150+ 300		A-Flange Class 600		A-Flanged DIN*	
	Std. Port	Full Port	Std. Port	Full Port	Std. Port	Std. Port	Std. Port	Full Port	Std. Port	Full Port	Std. Port	Full Port
DN8	35.0	-	155.0	-	119.0	-	-	-	-	-	-	-
1/4"	1.38	-	6.10	-	4.69	-	-	-	-	-	-	-
DN10	35.0	-	155.0	-	151.4	-	-	-	-	-	130.0	-
3/8"	1.38	-	6.10	-	5.96	-	-	-	-	-	5.12	-
DN15	35.0	40.0	155.0	162.4	151.4	103.2	140.0	140.0	165.0	165.0	130.0	130.0
1/2"	1.38	1.57	6.10	6.39	5.96	4.06	5.51	5.51	6.50	6.50	5.12	5.12
DN20	40.0	49.0	162.4	186.0	162.4	117.0	152.0	152.0	190.0	190.0	150.0	150.0
3/4"	1.57	1.93	6.39	7.32	6.39	4.61	5.98	5.98	7.48	7.48	5.91	5.91
DN25	49.0	49.0	186.0	187.0	181.3	131.6	165.0	165.0	216.0	216.0	160.0	160.0
1"	1.93	1.93	7.32	7.36	7.14	5.18	6.50	6.50	8.50	8.50	6.30	6.30
DN32	49.0	70.0	187.0	211.0	187.0	-	178.0	178.0	229.0	229.0	180.0	180.0
1 1/4"	1.93	2.76	7.36	8.31	7.36	-	7.01	7.01	9.02	9.02	7.09	7.09
DN40	70.0	70.0	211.0	214.0	205.6	161.4	190.0	190.0	241.0	241.0	200.0	200.0
1 1/2"	2.76	2.76	8.31	8.43	8.09	6.35	7.48	7.48	9.49	9.49	7.87	7.87
DN50	70.0	94.0	214.0	254.0	207.2	172.6	216.0	216.0	292.0	292.0	230.0	230.0
2"	2.76	3.70	8.43	10.0	8.16	6.80	8.50	8.50	11.50	11.50	9.06	9.06
DN65	94.0	115.0	254.0	315.0	254.0	234.4	241.0	241.0	330.0	330.0	290.0	290.0
2 1/2"	3.70	4.53	10.0	12.40	10.0	9.23	9.49	9.49	12.99	12.99	11.42	11.42
DN80	115.0	130.0	315.0	370.0	315.0	-	282.0	282.0	356.0	356.0	310.0	310.0
3"	4.53	5.12	12.40	14.57	12.40	-	11.10	11.10	14.02	14.02	12.20	12.20
DN100	130.0	175.0	370.0	442.0	370.0	-	305.0	305.0	432.0	432.0	350.0	350.0
4"	5.12	6.89	14.57	17.40	14.57	-	12.01	12.01	17.01	17.01	13.78	13.78
DN150	175.0	-	473.0	-	473.0	-	403.0	-	559.0	-	480.0	-
6"	6.89	-	18.62	-	18.62	-	15.87	-	22.01	-	18.90	-

* PN16-PN100

XBW / ETO / ETI / ETD

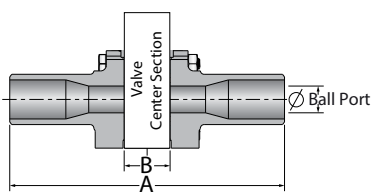

Flanged

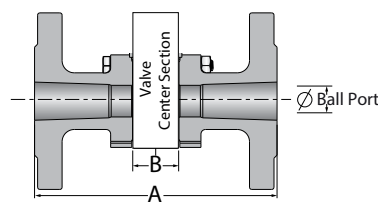

TC

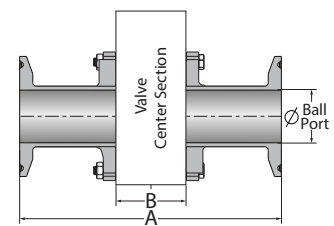
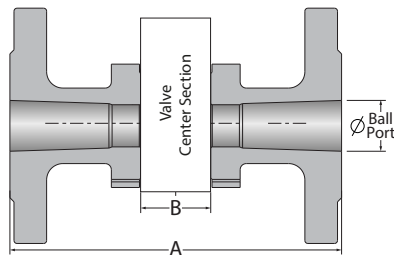
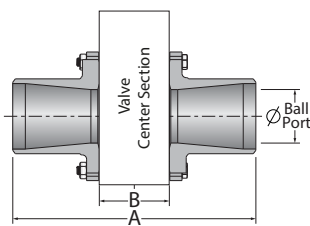
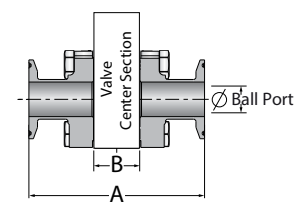

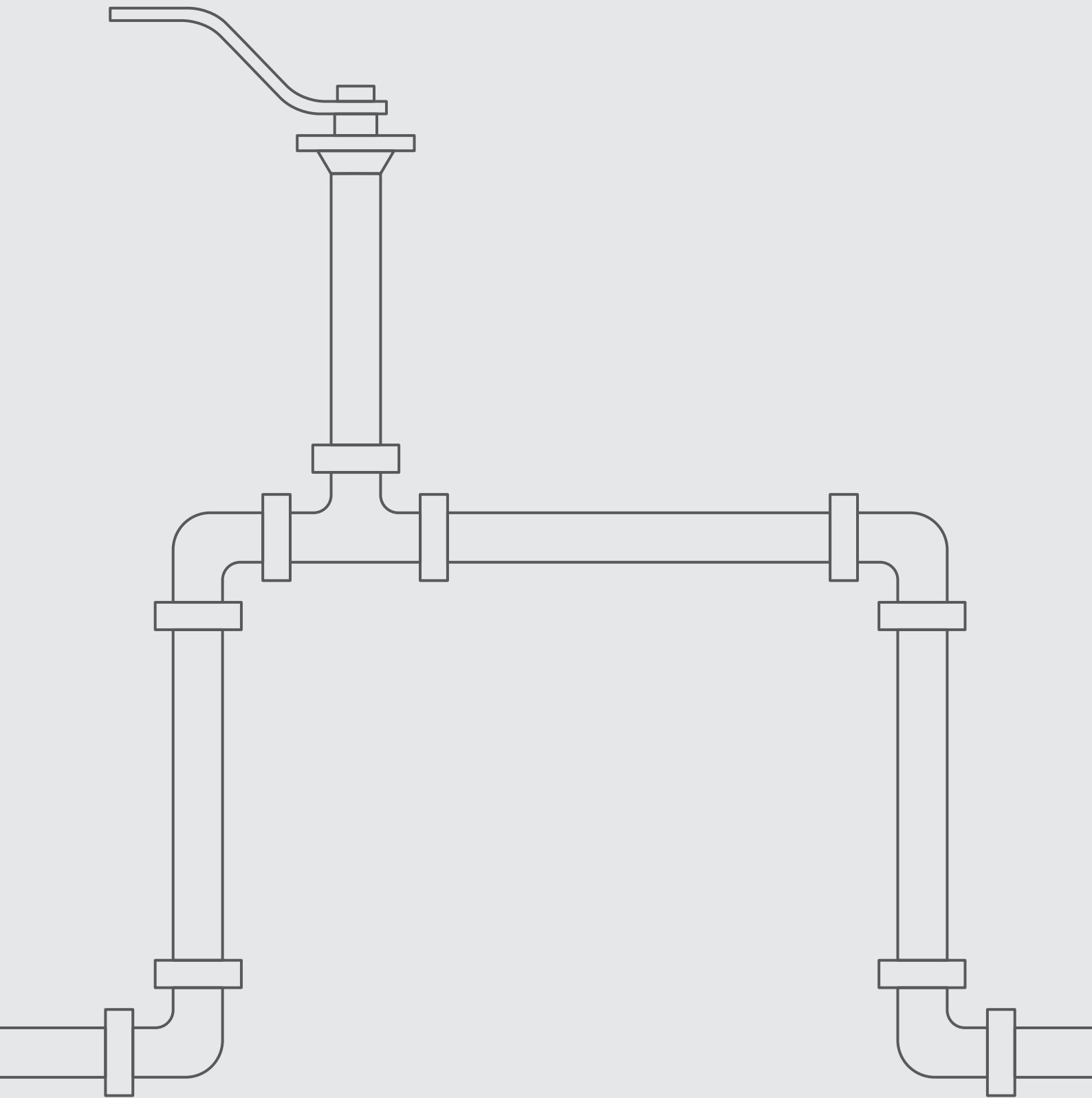

Z28



High Temp. Valves

FLOATING BALL

HIGH PRESSURE
3 PIECE

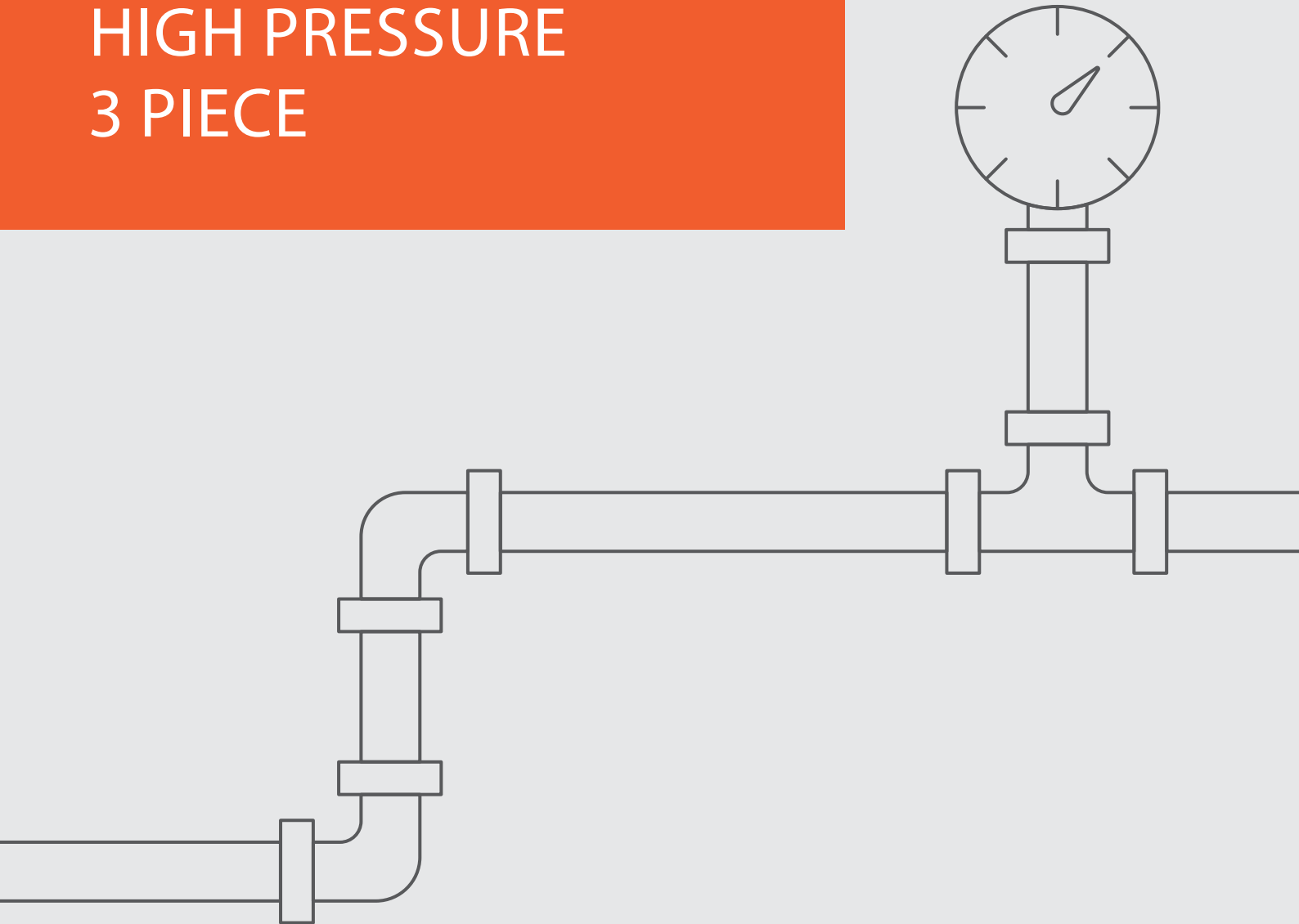

Z28W**Z28Z**

1/2"-1 1/4" | DN15-DN32 | CLASS 2500

HP Floating Ball 3 Piece Up to **W** 260°C (500°F) | **Z** 450°C (842°F)

Valve Dimensions

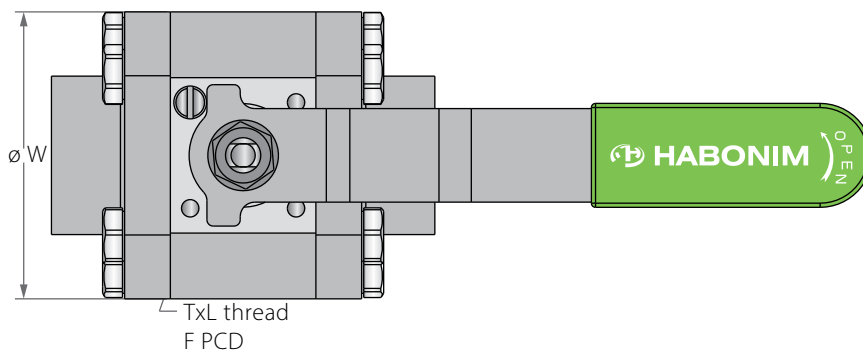
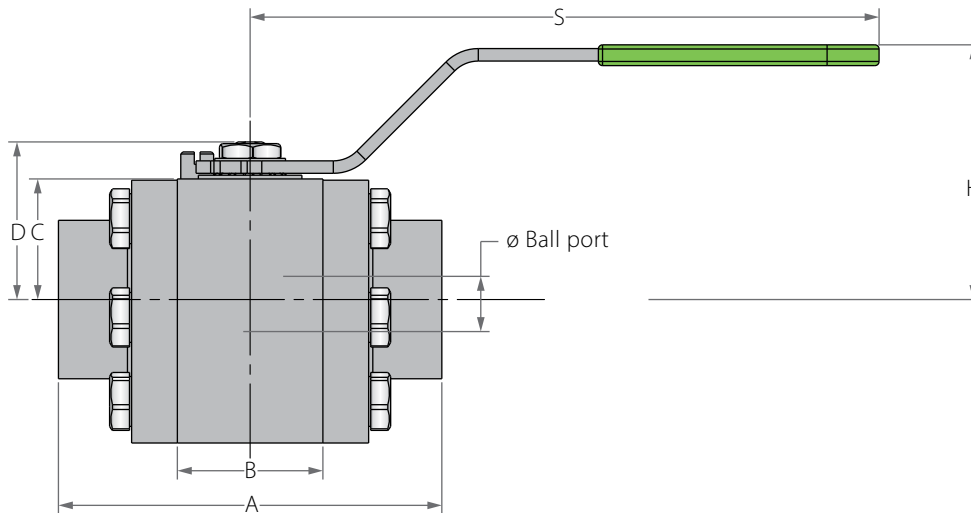

Preparation for actuation

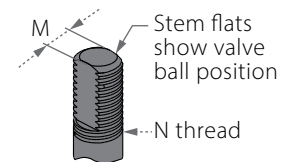
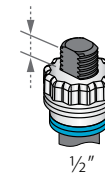

Std. port	Full port	Unit	Ball port	A THD	A XBW/XSW	B	C	D	H	S	W	M	N	P	F	TxL	Weight kg/lb	Kv Cv	
DN15	DN8, DN10	mm	11.15	92.2	158.6	35.0	29.0	37.9	63.0	150.0	45.5	5.5	3/8" UNF	6.65	F03	36.0	M5X6	2.8	7
1/2"	1/4", 3/8"	inch	0.44	3.63	6.24	1.38	1.14	1.49	2.48	5.91	1.79	0.22		0.26		1.42		6.16	8
DN20	DN15	mm	13.0	100.0	168.6	40.0	34.1	51.0	76.5	187.0	89.0	7.5	7/16" UNF	6.65	F04	42.0	M5X8	4.3	10
3/4"	1/2"	inch	0.51	3.94	6.64	1.57	1.34	2.01	3.01	7.36	3.50	0.30		0.26		1.65		9.46	12
DN25	DN20	mm	20.6	125.2	189.6	49.0	43.75	65.9	90.0	237.0	104.0	8.7	9/16" UNF	6.65	F05	50.0	M6X8	6.8	28
1"	3/4"	inch	0.81	4.93	7.46	1.93	1.72	2.59	3.54	9.33	4.09	0.34		0.26		1.97		14.96	32
DN32	DN25	mm	25.4	133.0	192.6	49.0	51.5	69.5	92.5	237.0	69.0	8.7	9/16" UNF	6.65	F05	50.0	M6X9	9.5	49
1 1/4"	1"	inch	1.0	5.24	7.58	1.93	2.03	2.74	3.64	9.33	2.72	0.34		0.26		1.97		20.90	57

Z28W**Z28Z**

1/2"-1 1/4" | DN15-DN32 | CLASS 2500



HP Floating Ball 3 Piece Up to **W** 260°C (500°F) | **Z** 450°C (842°F)

Components & Materials

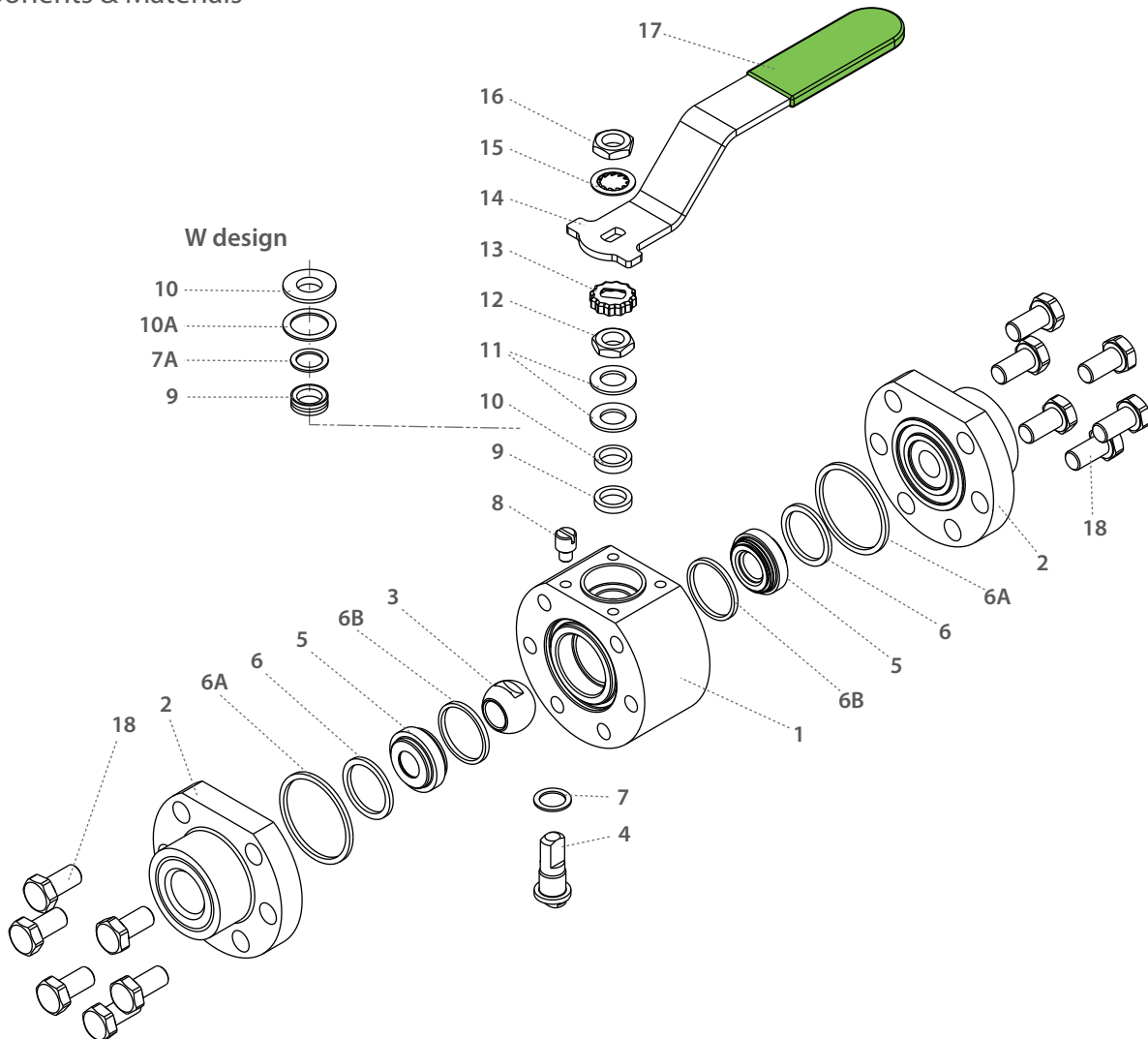

Item	Description	Material specification	Qty.
1	Body	Acc. Ordering Code	1
2	Ends	Acc. Ordering Code	2
3**	Ball	Acc. Ordering Code	1
4	Stem	Acc. Ordering Code	1
5**	Seat Assembly	Acc. Ordering Code	1
6*	Inner Body Seal	Graphite	2
6A*	Outer Body Seal	Graphite	2
6B*	Seat Seal	Graphite	2
7*	Stem Thrust Seal	Graphite + Inconel, PEEK	1
7A*	Anti Abrasion Ring	PEEK	1
8	Stop Pin	S. Steel	1
9*	Stem Seal	Graphite, CF PTFEM	1

Item	Description	Material specification	Qty.
10	Follower	S. Steel	1
10A*	Slide Bearing	S. Steel	1
12	Stem Nut	S. Steel	1
13	Tab Lock Washer	S. Steel	1
14	Handle	S. Steel	1
14A	Stop Plate	S. Steel	1
14B	Wrench Head	S. Steel	1
16	Wrench Bolt	S. Steel	1
17	Sleeve	PVC	1
18	Body Bolts	S. Steel	16-24
23	Tag (not shown)	S. Steel	1

* Seals kit components

** Ball and seats kit components

Z28W**Z28Z**

1½"-6" | DN40-DN150 | CLASS 2500

HP Floating Ball 3 Piece Up to **W** 260°C (500°F) | **Z** 450°C (842°F)

Valve Dimensions

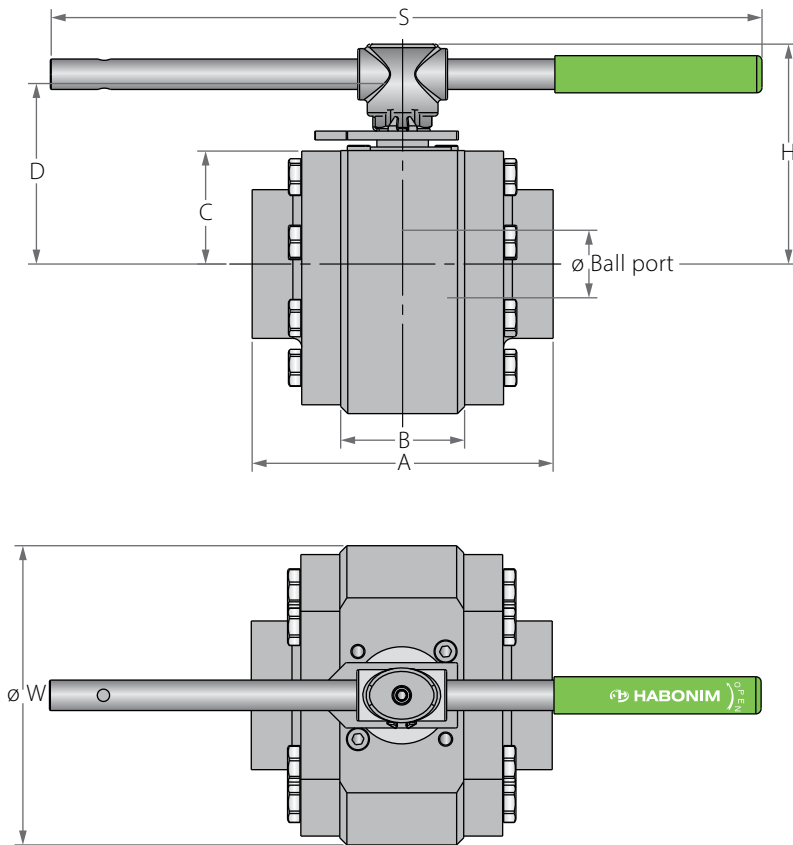

Preparation for actuation

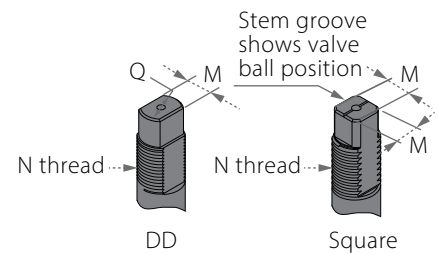
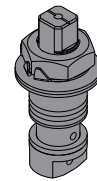

Std. port	Full port	Unit	Ball port	A THD	A XBW/XSW	B	C	D	H	S	W	M	N	P	F	TxL	Weight kg/lb	Kv Cv	
DN40	DN32	mm	31.8	154.0	237.0	70.0	53.0	94.6	120.0	400.0	79.0	13.9	M20x2.5	6.65	F07	70.0	M8X12	14.5	69
1½"	1¼"	inch	1.25	6.06	9.33	2.76	2.09	3.72	4.72	15.75	3.11	0.55		0.26		2.76		31.90	80
DN50	DN40	mm	38.1	170.0	241.0	70.0	64.1	105.7	124.0	400.0	90.5	13.9	M20x2.5	14.6	F07	70.0	M8X12	22.0	102
2"	1½"	inch	1.50	6.69	9.49	2.76	2.52	4.16	4.88	15.75	3.56	0.55		0.57		2.76		48.40	118
DN65	DN50	mm	50.8	214.0	302.4	94.0	87.5	134.0	158.5	610.0	108.0	18.9	1"-14 UNS-2A	16.7	F10	102.0	M10X16	36.0	208
2½"	2"	inch	2.0	8.43	11.91	3.70	3.44	5.28	6.24	24.02	4.25	0.74		0.66		4.02		79.20	241
DN80	DN65	mm	63.5	276.6	378.0	115.0	112.0	181.5	227.0	916.0	250.0	28.45	1½"-12 UNF-2A	26.2	F12	125.0	M12X15	76.0	301
3"	2½"	inch	2.50	10.89	14.88	4.53	4.41	7.15	8.94	36.06	9.84	1.12		1.03		4.92		167.20	348
DN100	DN80	mm	82.7	-	410.0	130.0	136.0	205.5	265.0	916.0	298.0	28.45	1½"-12 UNF-2A	26.2	F12	125.0	M12X15	110.0	616
4"	3"	inch	3.26	-	16.14	5.12	5.35	8.09	10.43	36.06	11.73	1.12		1.03		4.92		242.00	713
DN150	DN100	mm	100.0	-	615.0	175.0	177.0	289.6	-	-	389.0	35.9	2"-8 UN-2A	40.0	F14	140.0	M16X20	235.0	746
6"	4"	inch	3.94	-	24.21	6.89	6.97	11.40	-	-	15.31	1.41		1.57		5.51		517.00	863

Z28W**Z28Z**

1½"-6" | DN40-DN150 | CLASS 2500



HP Floating Ball 3 Piece Up to **W** 260°C (500°F) | **Z** 450°C (842°F)

Components & Materials

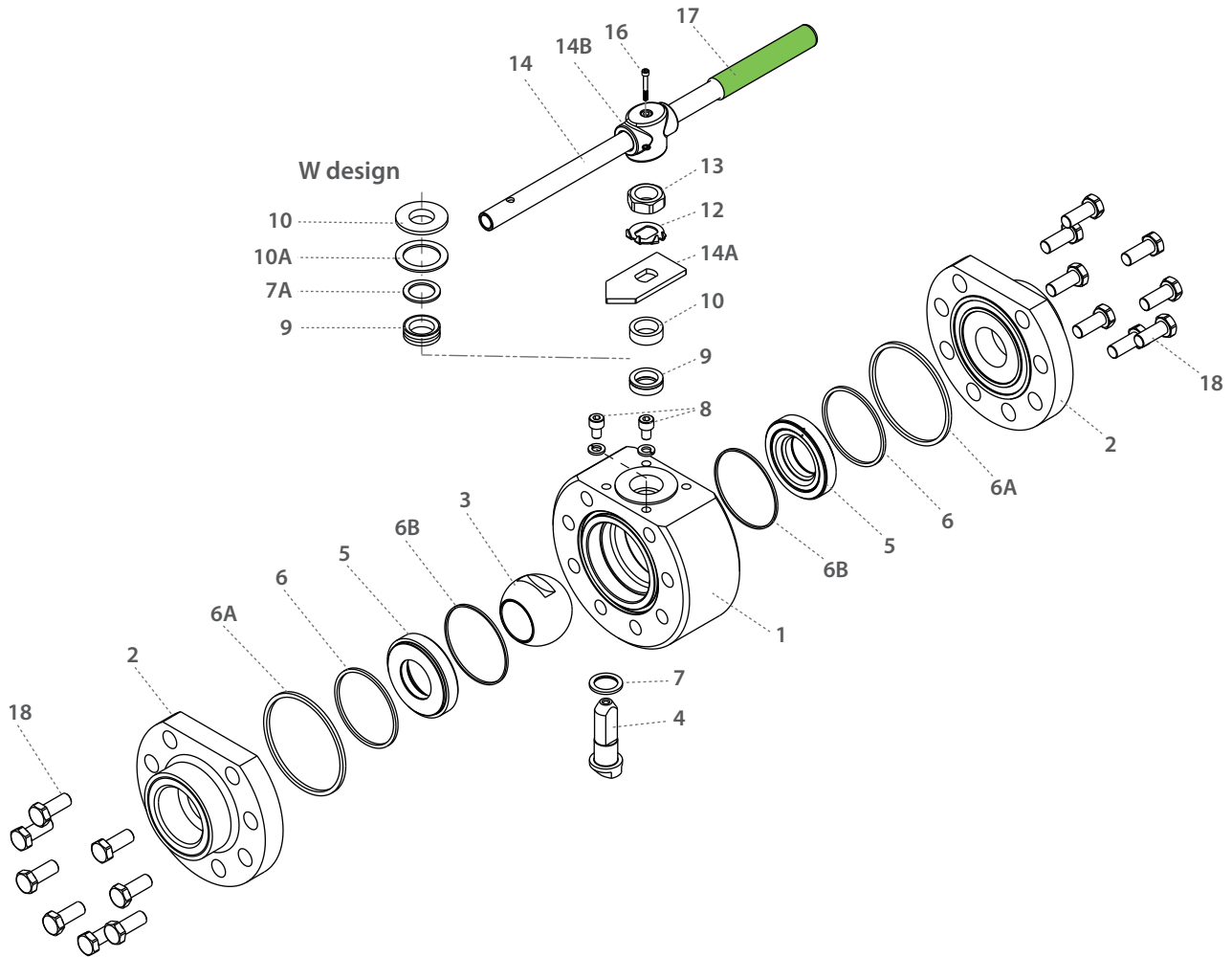

Item	Description	Material specification	Qty.
1	Body	Acc. Ordering Code	1
2	Ends	Acc. Ordering Code	2
3**	Ball	Acc. Ordering Code	1
4	Stem	Acc. Ordering Code	1
5**	Seat Assembly	Acc. Ordering Code	2
6*	Inner Body Seal	Graphite	2
6A*	Outer Seat Seal	Graphite	2
6B*	Seat Seal	Graphite	2
7*	Stem Thrust Seal	Graphite + Inconel, PEEK	1
7A*	Anti Abrasion Ring	PEEK	1
8	Stop Pin	S. Steel	2
9*	Stem Seal	Graphite, CF PTFE	1

Item	Description	Material specification	Qty.
10	Follower	S. Steel	1
10A*	Slide Bearing	S. Steel	1
12	Stem Nut	S. Steel	1
13	Tab Lock Washer	S. Steel	1
14	Handle	S. Steel	1
14A	Stop Plate	S. Steel	1
14B	Wrench Head	S. Steel	1
16	Wrench Bolt	S. Steel	1
17	Sleeve	PVC	1
18	Body Bolts	S. Steel	16-24
23	Tag (not shown)	S. Steel	1

* Seals kit components

** Ball and seats kit components

Z28W

Z28Z

Face To Face Sizes

Valve Size	B		A-XBW, XSW, GR		A-Flange #900		A-Flange #900 RTJ		A-Flange #1500		A-Flange #1500RTJ		A-Flange #2500		A-Flange #2500RTJ		PN250-PN400 F3	
	Std. port	Full port	Std. port	Full port	Std. port	Full port	Std. port	Full port	Std. port	Full port	Std. port	Full port	Std. port	Full port	Std. port	Full port	Std. port	Full port
DN8	35	-	158.6	-	-	-	-	-	-	-	-	-	-	-	-	-	-	-
1/4"	1.38	-	6.24	-	-	-	-	-	-	-	-	-	-	-	-	-	-	-
DN10	35	-	158.6	-	-	-	-	-	-	-	-	-	-	-	-	-	230.0	-
3/8"	1.38	-	6.24	-	-	-	-	-	-	-	-	-	-	-	-	-	9.06	-
DN15	35	40.0	158.6	168.6	216.0	216.0	216.0	216.0	216.0	216.0	216.0	216.0	264.0	264.0	264.0	264.0	230.0	230.0
1/2"	1.38	1.57	6.24	6.64	8.50	8.50	8.50	8.50	8.50	8.50	8.50	8.50	10.39	10.39	10.39	10.39	9.06	9.06
DN20	40	49.0	168.6	189.6	229.0	229.0	229.0	229.0	229.0	229.0	229.0	229.0	273.0	273.0	273.0	273.0	260.0	260.0
3/4"	1.57	1.93	6.64	7.46	9.02	9.02	9.02	9.02	9.02	9.02	9.02	9.02	10.75	10.75	10.75	10.75	10.24	10.24
DN25	49	49.0	189.6	192.6	254.0	254.0	254.0	254.0	254.0	254.0	254.0	254.0	308.0	308.0	308.0	308.0	260.0	260.0
1"	1.93	1.93	7.46	7.58	10.0	10.0	10.0	10.0	10.0	10.0	10.0	10.0	12.13	12.13	12.13	12.13	10.24	10.24
DN32	49.0	70.0	192.6	237.0	279.0	279.0	279.0	279.0	279.0	279.0	279.0	279.0	349.0	349.0	352.0	352.0	300.0	300.0
1 1/4"	1.93	2.76	7.58	9.33	10.98	10.98	10.98	10.98	10.98	10.98	10.98	10.98	13.74	13.74	13.86	13.86	11.81	11.81
DN40	70.0	70.0	237.0	241.0	305.0	305.0	305.0	305.0	305.0	305.0	305.0	305.0	384.0	384.0	387.0	387.0	300.0	300.0
1 1/2"	2.76	2.76	9.33	9.49	12.01	12.01	12.01	12.01	12.01	12.01	12.01	12.01	15.12	15.12	15.24	15.24	11.81	11.81
DN50	70.0	94.0	241.0	302.4	368.0	368.0	371.0	371.0	368.0	368.0	371.0	371.0	451.0	451.0	454.0	454.0	350.0	350.0
2"	2.76	3.70	9.49	11.91	14.49	14.49	14.61	14.61	14.49	14.49	14.61	14.61	17.76	17.76	17.87	17.87	13.78	13.78
DN65	94.0	115.0	302.4	378.0	419.0	419.0	422.0	422	419.0	419.0	422.0	422.0	508.0	508.0	514.0	514.0	400.0	400.0
2 1/2"	3.70	4.53	11.91	14.88	16.50	16.50	16.61	16.61	16.50	16.50	16.61	16.61	20.0	20.0	20.24	20.24	15.75	15.75
DN80	115.0	130.0	378.0	410.0	381.0	381.0	384.0	384.0	470.0	470.0	473.0	473.0	578.0	578.0	584.0	584.0	450.0	450.0
3"	4.53	5.12	14.88	16.14	15.0	15.0	15.12	15.12	18.50	18.50	18.62	18.62	22.76	22.76	22.99	22.99	17.72	17.72
DN100	130.0	175	410.0	510.0	457.0	457.0	460.0	460.0	546.0	546.0	549.0	549.0	673.0	673.0	683.0	683.0	520.0	520.0
4"	5.12	6.89	16.14	20.08	17.99	17.99	18.11	18.11	21.50	21.50	21.61	21.61	26.50	26.50	26.89	26.89	20.47	20.47
DN150	175.0	-	510.0	-	610.0	-	457.0	-	705.0	-	711.0	-	914.0	-	927.0	-	700.0	-
6"	6.89	-	20.08	-	24.02	-	17.99	-	27.76	-	27.99	-	35.98	-	36.50	-	27.56	-



High Temperature - Ordering Code System

"Mandatory option" options are marked with **green background** | "Standard offer" options are marked with **light green background**

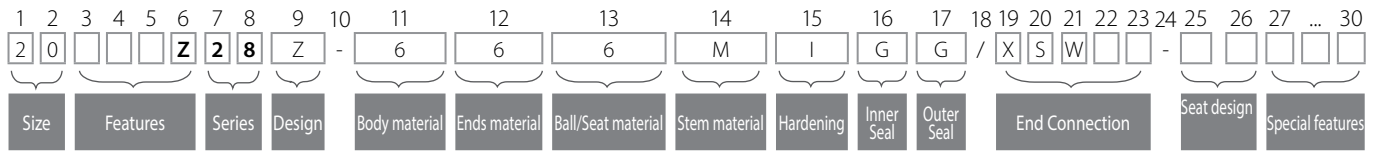

Size (1-2)		
Code	inch	mm
02	¼"	8
03	⅜"	10
05	½"	15
07	¾"	20
10	1"	25
12	1¼"	32
15	1½"	40
20	2"	50
25	2½"	65
30	3"	80
40	4"	100
60	6"	150

Features (3-6)	
Z	Metal seats
B	Full Port
N	Control service

Series (7-8)	
28	HP Floating ball 3 piece

Design (9)	
Z	-60°C to 450°C (-76°F to 842°F)
W	-60°C to 260°C (-76°F to 500°F) HermetiX stem seal

Body Material (11)	
6	S. Steel 316L
F*	LF2

* 425°C (800°F)

Ends Material (12)	
6	316
F*	LF2

* 425°C (800°F)

Ball / Seat material (13) Sizes up to ¾" std. port	
M*	High Strength S. Steel

* ball - XM19, seat - 316

Ball / Seat material (13) Sizes ¾" full bore and up	
6	316
N*	St. Steel 410

* For O hardening only

Stem material (14)	
M	High Strength S. Steel
Z	Inconel 718

Hardening (15)	
I	Cr3C2- Chromium Carbide with Nickel Chrome binder- HVOF technique
O*	WC-Co- Tungsten Carbide with Coblat binder- HVOF technique

* Only with N ball material

Inner Seal (16)	
G	Expanded graphite
B*	NBR
V**	Viton
K***	FFKM

* Up to 80°C (175°F)
 ** Up to 120°C (250°F)
 *** Up to 327°C (620°F)

Outer Seal (17)	
G	Expanded graphite

End connections (19-23)	
Welded Ends	
XBW160*	Extended butt weld ends (sch160)
XSW	Extended socket weld ends
SW	Socket weld ends
BW80	butt weld ends (sch80)
BW160*	butt weld ends (sch160)
XBW80	Extended butt weld ends (sch80)
XBWXXS *	Extended butt weld ends (sch XXS)
Threaded Ends	
NPT	ASME B1.20.1 - National Pipe Taper thread
BSPT	EN 10226 - Pipe Taper thread
BSPP	ISO228-1, DIN3852 - Pipe Parallel thread
DIN3852	DIN3852 - Pipe Parallel thread
AS5202	AS 5202 on-face gasket sealing threaded connection
Flanged	
1500	ANSI B16.5 #1500 RF
2500	ANSI B16.5 #2500 RF
PN160-F3	EN1092 PN160, FTF F3
PN250-F3	EN1092 PN250, FTF F3
PN320-F3	EN1092 PN320, FTF F3
PN400-F3	EN1092 PN400, FTF F3
Flanged RTJ	
1500RTJ	ANSI B16.5 #1500 RTJ
2500RTJ	ANSI B16.5 #2500 RTJ
Flanged SAE J518 / ISO 6162 Threaded	
SAE3000	Code 61/ISO 6162-1 Flat face
SAE6000	Code 62/ISO 6162-2 Flat face

* Std. port only

Seat design (25-26)	
Blank	(New type)

Special Features (27-30)	
Vxx	Characterized control ball xx = angle

Z28Q 1/4"-1 1/4" | DN8-DN32 | CLASS 2500

High Temperature HP Floating Ball 3 Piece Up to 650°C (1200°F)

Valve Dimensions

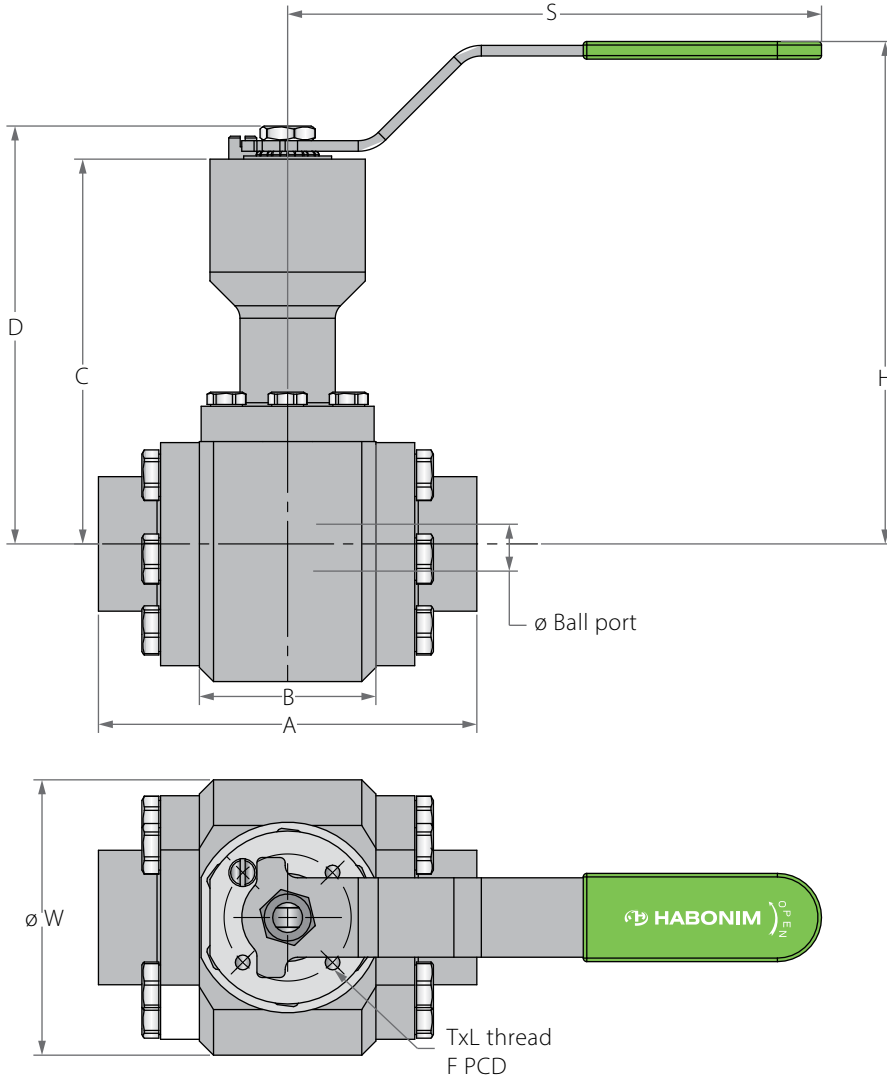

Preparation for actuation

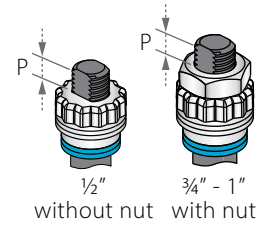

1/2" without nut
3/4" - 1" with nut

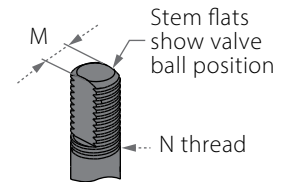

Std. port	Full port	Unit	Ball port	A THD	A XBW/XSW	B	C	D	H	S	W	M	N	P	F	TxL	Weight kg/lb	Kv Cv	
DN15	DN8, DN10	mm	11.15	107.2	173.6	50	129	137.9	163	150.0	78.0	5.5	3/8" UNF	6.5	F03	36.0	M5X6	3.5	7
1/2"	1/4", 3/8"	inch	0.44	4.22	6.83	1.97	5.08	5.43	6.42	5.91	3.07	0.22		0.26		1.42		7.70	8
DN20	DN15	mm	13.0	120.0	188.6	60.0	134.1	151	176.5	187.0	98.0	7.5	7/16" UNF	6.5	F04	42.0	M5X8	6.5	10
3/4"	1/2"	inch	0.51	4.72	7.43	2.36	5.28	5.94	6.95	7.36	3.86	0.30		0.26		1.65		14.30	12
DN25	DN20	mm	20.6	144.2	208.6	68.0	143.75	165.85	190	237.0	114.0	8.7	9/16" UNF	6.5	F05	50.0	M6X8	10.0	28
1"	3/4"	inch	0.81	5.68	8.21	2.68	5.66	6.53	7.48	9.33	4.49	0.34		0.26		1.97		22.0	32
DN32	DN25	mm	25.4	152	211.6	68	151.5	169.5	192.5	237.0	128.0	8.7	9/16" UNF	6.5	F05	50.0	M6X9	12.0	49
1 1/4"	1"	inch	1.0	5.98	8.33	2.68	5.96	6.67	7.58	9.33	5.04	0.34		0.26		1.97		26.40	57



High Temperature HP Floating Ball 3 Piece Up to 650°C (1200°F)

Components & Materials

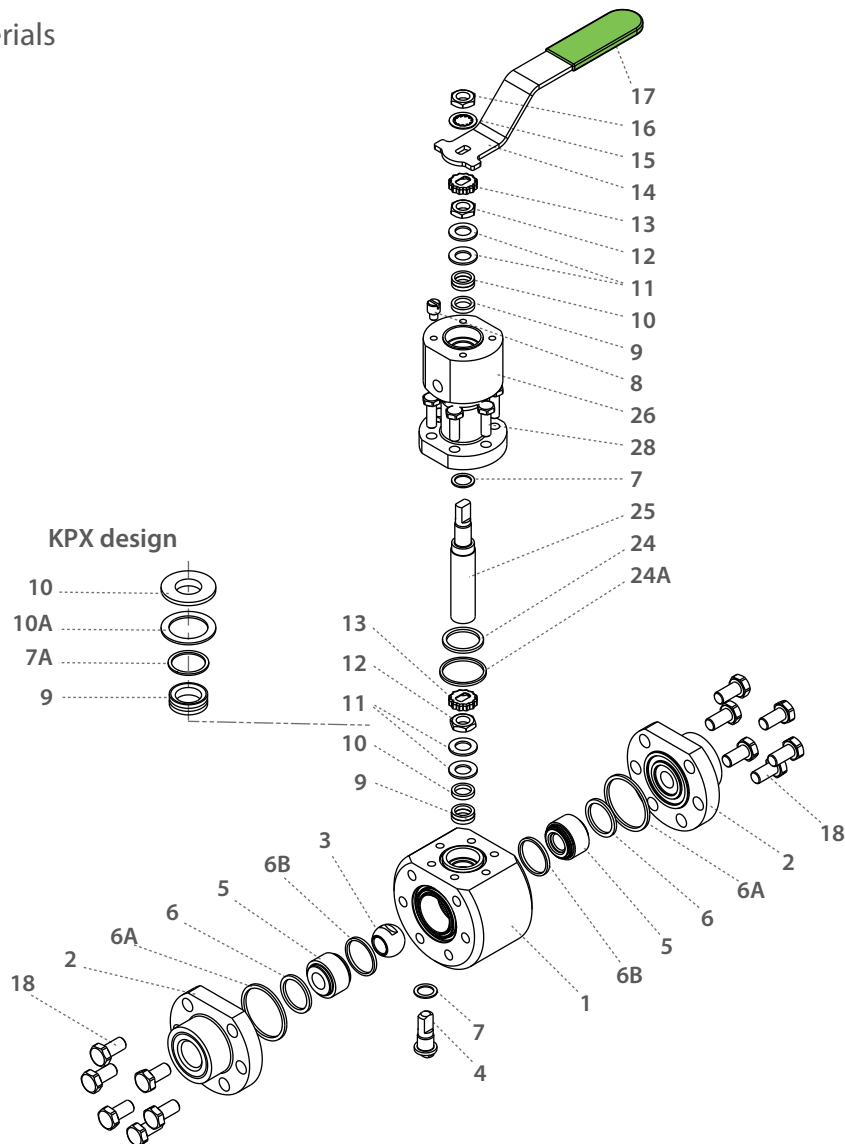

Item	Description	Material specification	Qty.
1	Body	Acc. Ordering Code	1
2	Ends	Acc. Ordering Code	2
3**	Ball	Acc. Ordering Code	1
4	Stem	Acc. Ordering Code	1
5**	Seat Assembly	Acc. Ordering Code	2
6*	Inner Body Seal	Graphite	2
6A*	Outer Body Seal	Graphite	2
6B*	Inner Body Seal	Graphite	2
7*	Stem Thrust Seal	Graphite + Inconel, PEEK	2
7A*	Anti Abrasion Ring	PEEK	1
8	Stop Pin	S. Steel	1
9*	Stem Seal	Graphite, CF PTFE	2
10	Follower	S. Steel	1
10A*	Slide Bearing	S. Steel	1
11	Disc Spring	S. Steel	4
12	Stem Nut	S. Steel	2

Item	Description	Material specification	Qty.
13	Locking Clip	S. Steel	2
14	Handle	S. Steel	1
15	Serrated Washer	S. Steel	1
16	Handle Nut	S. Steel	1
17	Sleeve	PVC	1
18	Body Bolts	S. Steel	12-16
22	Arrow Flow	S. Steel	1
23	Tag (not shown)	S. Steel	1
24*	Inner Bonnet Seal	Graphite	1
24A*	Outer Bonnet Seal	Graphite	1
25	Bonnet stem High Temp	S. Steel	1
26	Bonnet High Temp	S. Steel	1
28	Bonnet Bolts	S. Steel	6

* Seals kit components

** Ball and seats kit components

Z28Q 1½"-6" | DN40-DN150 | CLASS 2500

High Temperature HP Floating Ball 3 Piece Up to 650°C (1200°F)

Valve Dimensions

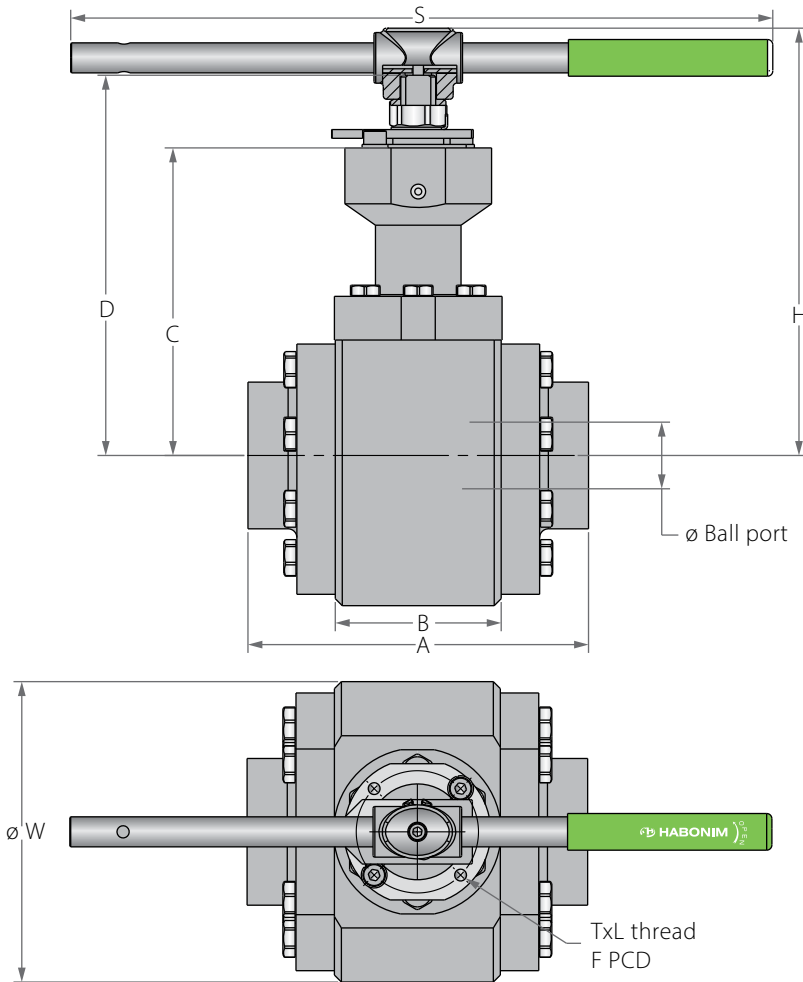

Preparation for actuation

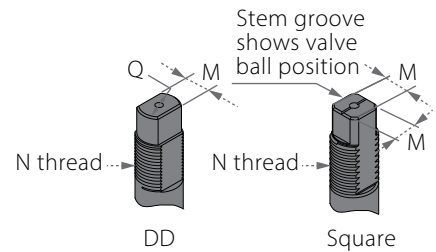
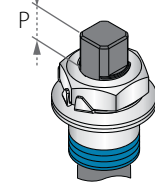

Std. port	Full port	Unit	Ball port	A THD	A XBW/XSW	B	C	D	H	S	W	M	N	P	F	TxL	Weight kg/lb	Kv Cv	
DN40	DN32	mm	31.8	179.0	262.0	95.0	203.0	244.6	270.0	400.0	140.0	13.9	M20x2.5	13.5	F07	70.0	M8X12	20.0	69
1½"	1¼"	inch	1.25	7.05	10.31	3.74	7.99	9.63	10.63	15.75	5.51	0.55		0.53		2.76		44.0	80
DN50	DN40	mm	38.1	195.0	266.0	95.0	214.1	255.7	274.0	400.0	172.0	13.9	M20x2.5	14.6	F07	70.0	M8X12	30.0	102
2"	1½"	inch	1.50	7.68	10.47	3.74	8.43	10.07	10.79	15.75	6.77	0.55		0.57		2.76		66.0	118
DN65	DN50	mm	50.8	225.0	313.4	105.0	237.5	284.0	308.5	610.0	204.0	18.9	1"-14 UNS-2A	16.7	F10	102.0	M10X16	42.0	208
2½"	2"	inch	2.0	8.86	12.34	4.13	9.35	11.18	12.15	24.02	8.03	0.74		0.66		4.02		92.40	241
DN80	DN65	mm	63.5	301.6	403.0	140.0	262.0	331.5	377.0	916.0	268.0	28.5	1½"-12 UNF-2A	26.2	F12	125.0	M12X15	93.0	301
3"	2½"	inch	2.50	11.87	15.87	5.51	10.31	13.05	14.84	36.06	10.55	1.12		1.03		4.92		204.60	348
DN100	DN80	mm	82.7	-	420.0	140.0	286.0	355.5	415.0	916.0	298.0	28.5	1½"-12 UNF-2A	26.2	F12	125.0	M12X15	120.0	616
4"	3"	inch	3.26	-	16.54	5.51	11.26	14.0	16.34	36.06	11.73	1.12		1.03		4.92		264.0	713
DN150	DN100	mm	100.0	-	510.0	175.0	377.0	489.6	-	-	399.0	35.9	2"-8 UN-2A	40.0	F14	140.0	M16X20	260.0	746
6"	4"	inch	3.94	-	20.08	6.89	14.84	19.28	-	-	15.71	1.41		1.57		5.51		572.0	863



High Temperature HP Floating Ball 3 Piece Up to 650°C (1200°F)

Components & Materials

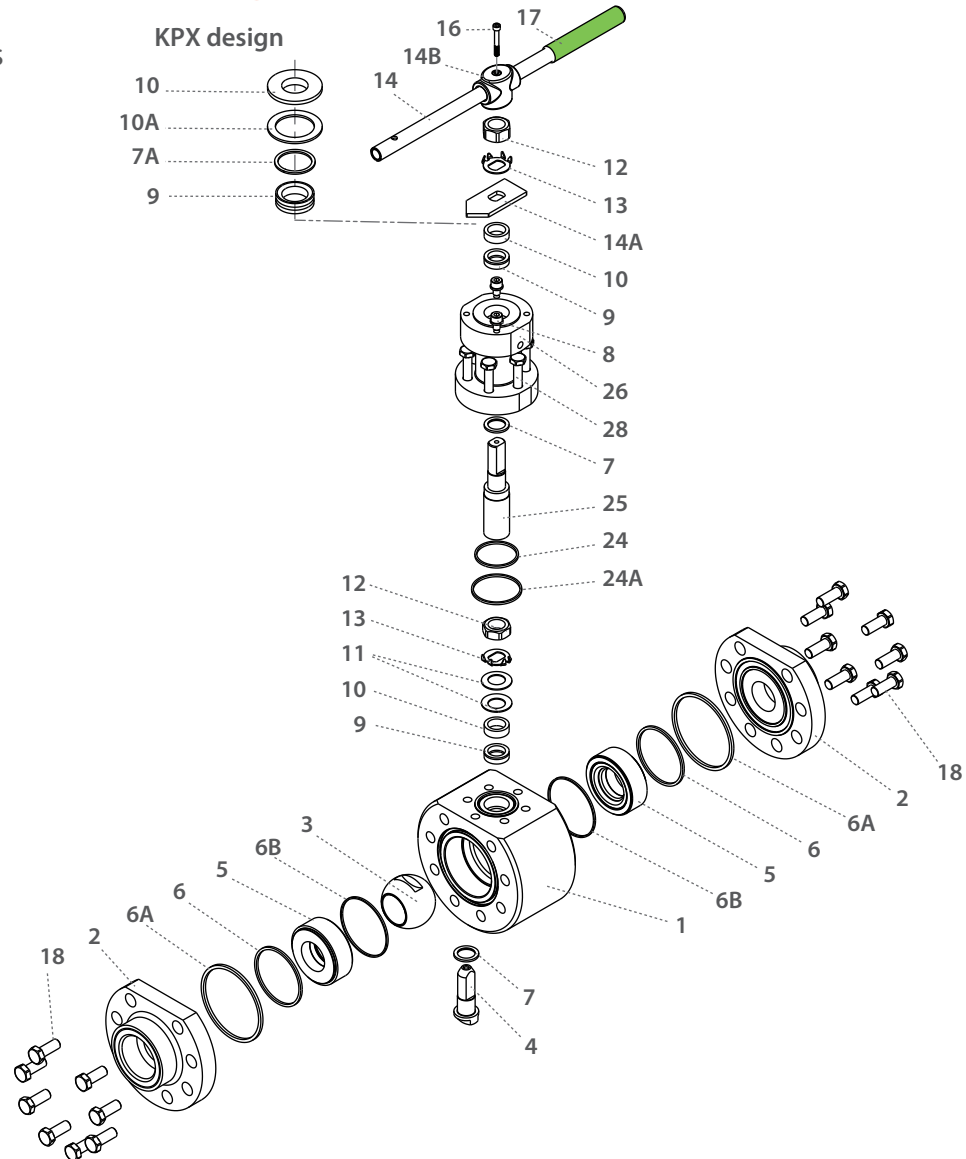

Item	Description	Material specification	Qty.
1	Body	Acc. Ordering Code	1
2	Ends	Acc. Ordering Code	2
3**	Ball	Acc. Ordering Code	1
4	Stem	Acc. Ordering Code	1
5**	Seat Assembly	Acc. Ordering Code	2
6*	Inner Body Seal	Graphite	2
6A*	Outer body Seal	Graphite	2
6B*	Seat Seal	Graphite	2
7*	Stem Thrust Seal	Graphite + Inconel, PEEK	2
7A*	Anti abrasion ring	PEEK	1
8	Stop Pin	S. Steel	2
9*	Stem Seal	Graphite, CF PTFE	2
10	Follower	S. Steel	2
10A*	Slide Bearing	S. Steel	1
11	Disc Spring	S. Steel	2
12	Stem Nut	S. Steel	2

Item	Description	Material specification	Qty.
13	Tab Lock Washer	S. Steel	2
14***	Handle	S. Steel	1
14A	Stop Plate	S. Steel	1
14B	Wrench Head	S. Steel	1
16	Wrench Bolt	S. Steel	1
17	Sleeve	PVC	1
18	Body Bolts	S. Steel	16-24
23	Tag (not shown)	S. Steel	1
24*	Inner Bonnet Seal	Graphite	1
24A	Outer Bonnet Seal	Graphite	1
25	Bonnet Stem High Temp	S. Steel	1
26	Bonnet High Temp	S. Steel	1
28	Bonnet Bolts	S. Steel	6-8

* Seals kit components

** Ball and seats kit components

*** Gear operator should be used for size 3" DN80 and above (handle components are not included)

Face To Face Sizes

Valve Size	B		A-XBW, XSW, GR		A-Flange #900		A-Flange #900 RTJ		A-Flange #1500		A-Flange #1500RTJ		A-Flange #2500		A-Flange #2500RTJ		PN250-PN400 F3	
	Std. port	Full port	Std. port	Full port	Std. port	Full port	Std. port	Full port	Std. port	Full port	Std. port	Full port	Std. port	Full port	Std. port	Full port	Std. port	Full port
DN8	50.0	-	173.6	-	-	-	-	-	-	-	-	-	-	-	-	-	-	-
1/4"	1.97	-	6.83	-	-	-	-	-	-	-	-	-	-	-	-	-	-	-
DN10	50.0	-	173.6	-	-	-	-	-	-	-	-	-	-	-	-	-	230.0	-
3/8"	1.97	-	6.83	-	-	-	-	-	-	-	-	-	-	-	-	-	9.06	-
DN15	50.0	60.0	173.6	188.6	216.0	216.0	216.0	216.0	216.0	216.0	216.0	216.0	264.0	264.0	264.0	264.0	230.0	230.0
1/2"	1.97	2.36	6.83	7.43	8.50	8.50	8.50	8.50	8.50	8.50	8.50	8.50	10.39	10.39	10.39	10.39	9.06	9.06
DN20	60.0	68.0	188.6	208.6	229.0	229.0	229.0	229.0	229.0	229.0	229.0	229.0	273.0	273.0	273.0	273.0	260.0	260.0
3/4"	2.36	2.68	7.43	8.21	9.02	9.02	9.02	9.02	9.02	9.02	9.02	9.02	10.75	10.75	10.75	10.75	10.24	10.24
DN25	68.0	68.0	208.6	211.6	254.0	254.0	254.0	254.0	254.0	254.0	254.0	254.0	308.0	308.0	308.0	308.0	260.0	260.0
1"	2.68	2.68	8.21	8.33	10.0	10.0	10.0	10.0	10.0	10.0	10.0	10.0	12.13	12.13	12.13	12.13	10.24	10.24
DN32	68.0	95.0	211.6	262.0	279.0	279.0	279.0	279.0	279.0	279.0	279.0	279.0	349.0	349.0	352.0	352.0	300.0	300.0
1 1/4"	2.68	3.74	8.33	10.31	10.98	10.98	10.98	10.98	10.98	10.98	10.98	10.98	13.74	13.74	13.86	13.86	11.81	11.81
DN40	95.0	95.0	262.0	266.0	305.0	305.0	305.0	305.0	305.0	305.0	305.0	305.0	384.0	384.0	387.0	387.0	300.0	300.0
1 1/2"	3.74	3.74	10.31	10.47	12.01	12.01	12.01	12.01	12.01	12.01	12.01	12.01	15.12	15.12	15.24	15.24	11.81	11.81
DN50	95.0	105.0	266.0	313.4	368.0	368.0	371.0	371.0	368.0	368.0	371.0	371.0	451.0	451.0	454.0	454.0	350.0	350.0
2"	3.74	4.13	10.47	12.34	14.49	14.49	14.61	14.61	14.49	14.49	14.61	14.61	17.76	17.76	17.87	17.87	13.78	13.78
DN65	105.0	140.0	313.4	403.0	419.0	419.0	422.0	422.0	419.0	419.0	422.0	422.0	508.0	508.0	514.0	514.0	400.0	400.0
2 1/2"	4.13	5.51	12.34	15.87	16.50	16.50	16.61	16.61	16.50	16.50	16.61	16.61	20.0	20.0	20.24	20.24	15.75	15.75
DN80	140.0	150.0	403.0	430.0	381.0	381.0	384.0	384.0	470.0	470.0	473.0	473.0	578.0	578.0	584.0	584.0	450.0	450.0
3"	5.51	5.91	15.87	16.93	15.0	15.0	15.12	15.12	18.50	18.50	18.62	18.62	22.76	22.76	22.99	22.99	17.72	17.72
DN100	150	175	430	510.0	457.0	457.0	460.0	460.0	546.0	546.0	549.0	549.0	673.0	673.0	683.0	683.0	520.0	520.0
4"	5.91	6.89	16.93	20.08	17.99	17.99	18.11	18.11	21.50	21.50	21.61	21.61	26.50	26.50	26.89	26.89	20.47	20.47
DN150	175.0	-	510.0	-	610.0	-	457.0	-	705.0	-	711.0	-	914.0	-	927.0	-	700.0	-
6"	6.89	-	20.08	-	24.02	-	17.99	-	27.76	-	27.99	-	35.98	-	36.50	-	27.56	-



High Temperature - Ordering Code System

"Mandatory option" options are marked with **green background** | "Standard offer" options are marked with **light green background**

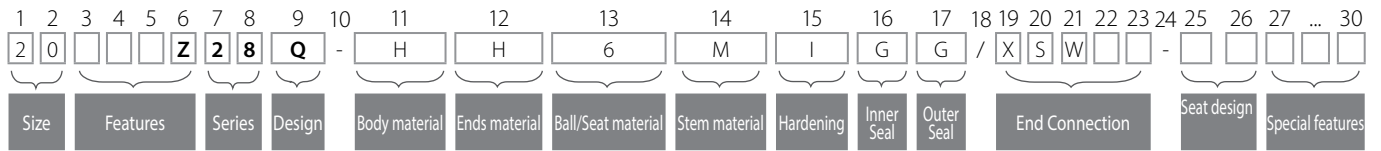

Size (1-2)		
Code	inch	mm
02	¼"	8
03	⅜"	10
05	½"	15
07	¾"	20
10	1"	25
12	1¼"	32
15	1½"	40
20	2"	50
25	2½"	65
30	3"	80
40	4"	100
60	6"	150
80*	8"	200

* std. port only

Features (3-6)	
Z	Metal seats
B	Full Port
N	Control service

Series (7-8)	
28	HP Floating ball 3 piece
Design (9)	
Q	-60°C to 650°C (-76°F to 1200°F)
Body Material (11)	
H	321H
J*	F22
* Up to 595°C (1100°F)	
Ends Material (12)	
H	321H
J*	F22
* Up to 595°C (1100°F)	
Ball / Seat material (13) Sizes up to ¾" std. port	
M*	High Strength S. Steel
* ball - XM19, seat - 316	
Ball / Seat material (13) Sizes ¾" full bore and up	
6	316
Stem material (14)	
M	High Strength S. Steel
Z	Inconel 718
Hardening (15)	
I	Cr3C2- Chromium Carbide with Nickel Chrome binder- HVOF technique
Inner Seal (16)	
G	Expanded graphite

Outer Seal (17)	
G	Expanded graphite
End connections (19-23)	
Welded Ends	
XBW160*	Extended butt weld ends (sch160)
XSW	Extended socket weld ends
SW	Socket weld ends
BW80	butt weld ends (sch80)
BW160*	butt weld ends (sch160)
XBW80	Extended butt weld ends (sch80)
XBWXXS*	Extended butt weld ends (sch XXS)
Threaded Ends	
NPT	ASME B1.20.1 - National Pipe Taper thread
BSPT	EN 10226 - Pipe Taper thread
BSPP	ISO228-1, DIN3852 - Pipe Parallel thread
DIN3852	DIN3852 - Pipe Parallel thread
AS5202	AS 5202 on-face gasket sealing threaded connection
* Std. port only	
Flanged*	
1500	ANSI B16.5 #1500 RF
2500	ANSI B16.5 #2500 RF
PN160-F3	EN1092 PN160, FTF F3
PN250-F3	EN1092 PN250, FTF F3
PN320-F3	EN1092 PN320, FTF F3
PN400-F3	EN1092 PN400, FTF F3
Flanged RTJ*	
1500RTJ	ANSI B16.5 #1500 RTJ
2500RTJ	ANSI B16.5 #2500 RTJ
* Up to 538°C (1,000°F)	
Seat design (25-26)	
Blank	(New type)
Special Features (27-30)	
Vxx	Characterized control ball xx = angle
KPX*	Bonnet top Hermetix
* Up to 550°C (1,022°F)	





YP0005123 CAT-PRD-MTNA-IM M Ver04_180326

About Habonim

Ball Valves & Actuators for the most demanding, challenging and hazardous applications are our passion and profession for the last 70 years.

We believe in designing, manufacturing and supplying control and shutoff components and solutions that improves the overall safety, integrity and sustainability of the systems they are installed in.

Designed, manufactured and tested according to the highest standards, our products allow us to partner within systems that flow and control varied gases and liquids in diverse markets especially where extreme temperatures and pressures are involved, hazardous materials are used and system performances are critical.

We are leading in cryogenic ball valve-based control solutions, emergency shutoff and specially designed solutions.

Believing that supplying and developing the most effective, safe and reliable products for the global leaders in the LNG and Gas distribution market continually challenges us to improve our capabilities and products.

Best coping with our prestigious customers' most challenging requirements technically, operationally and commercially is our promise fulfilled for decades.

Performing in Demanding Applications



www.habonim.com

Habonim USA +1 866 261 8400 | Habonim Canada +1 866 261 8400 | Habonim EU +31 79 204 0781 | Habonim Singapore +65 8127 0221
Habonim China +86 186 168 08766 | Habonim Israel +972 (0) 4 691 4911 | Habonim Australia +65 8127 0221 | Habonim Mexico +52 55 1384 3048