

Installation, Operating & Maintenance

Three Piece High Pressure Ball Valves

H21 Valves Series



Importer for European Union: Habonim Europe B.V. (EROI NL861781491B0)

Habonim USA 1 866 261 8400 | Habonim EU +31 79 204 0780 | Habonim Singapore +65 8127 0221 | Habonim China +86 18616808766
Habonim Israel +972 (0) 4 691 4911 | Habonim Australia +65 8127 0221

www.habonim.com

Item number: YP0009815

REV00-02/25

WARNINGS & SAFETY INSTRUCTIONS

Habonim cannot anticipate all the situations user may encounter while installing and using Habonim valves. The user **MUST** know and follow all applicable industry specifications on the safe installation and use of these valves.

Misapplication of the product may result in injuries or property damage. Refer to Habonim product catalogues, product brochures and installation, operating and maintenance manuals for additional product safety information or contact Habonim.

1. Always keep hands and objects away from the valve ports. Actuated valves could be accidentally operated, resulting in serious injury or valve damage.
2. Before removing a valve from the line, always make sure the line has been depressurized and drained. Cycle the valve a few times to relieve any pressure that could be trapped in the body cavity.
3. Utmost caution must be taken when handling a valve that has toxic, corrosive, flammable, or a contaminant nature media flowing through its pipeline. The following safety precautions are recommended when dismantling valves with hazardous media:
 - 3.1. Wear safety glasses, protective headgear, clothing, gloves and footwear.
 - 3.2. Have available running water.
 - 3.3. Have a suitable fire extinguisher when media is flammable.
4. Do not try to operate a valve that exhibits any sign of leakage. Isolate the valve and either repair or replace it.
5. Do not use or substitute non Habonim components or parts in Habonim valves and assemblies.

Three Piece High Pressure Ball Valves H21 Valves Series

Series included:
H21 Series

Sizes included:
1/4" – 2" (DN8 – DN50)



Contents

1. General	3
2. SIL	3
3. ATEX – Explosive Environment	3
4. Valves marking and labeling	4
5. Storage	5
6. Limitations	6
6.1. Erosion allowance	6
6.2. Lubrication and greasing	7
7. Installation	7
7.1. General	7
7.2. Installation of Uni-Directional valves	7
7.3. Installation in a vibrating environment	7
7.4. Installation of threaded end valves	8
8. Operating Instructions	8
9. Maintenance	8
10. Disassembly & Assembly Manual	10
10.1. General	10
10.2. Disassembly	10
10.3. Assembly	11

1. General

This Installation, Operating & Maintenance manual represents the instructions required for safe use of Habonim ball valve. The manual relates to reduce and full-bore valves.

Before using any of these series valves, read the entire IOM carefully and make sure everything is clear. If in doubt, please consult with Habonim.

2. SIL

Under severe operating conditions inspection should be more frequently; detected defects should be repaired promptly. Severe operating conditions can be defined as:

- Application temperature less or above than specified on the valve tag label.
- Flow velocity higher than 5 m/sec for liquids, and 200 m/sec for gaseous!
- Acidic media PH < 5 or alkaline media PH > 9

Habonim recommends a proof test interval of 12 months; in case of Fail to Open ESD system, a partial stroke is acceptable to confirm that the installation is functioning properly.

For ESD systems with a Fail-To-Close demand, it is necessary to plan a system shut-down; de-energize the system and inspect the valve turning to its fully closed position.

It is essential to log-in with the following parameters on site QA records.

as proof for preserving SIL capabilities: date, hour, name and signature of the responsible engineer, air pressure on site, time to close the valve, time to open the valve.

The combined corrosion and erosion allowance for the valve body wall thickness is 1 mm. When this allowance has been eroded or corroded, mechanically removed or otherwise, the valve should no longer be used. Inspect the valve wall thickness every time the valve is maintained.

The estimated mean time to repair (MTTR) a valve, i.e. time net (line draining or cooling down time excluded from the valve MTTR) of replacing old valve with a new one is 60 minutes. The maintenance team must read and understand the Habonim product IOM before starting the operation. In case of a doubt please consult the Habonim engineering team.

When a valve has been repaired or any maintenance was performed, check the valve for proper function (proof testing). Any failures affecting functional safety should be reported to the Habonim factory.

Proof test and maintenance

During a proof test operation, all the inner soft parts (seats, seals, stem packing and bearings) to be examine and replaced (only Habonim OEM repair kits can be used!) in interval less than 5 years to claim the valve assembly "**as-good-as-new**".

Habonim recommends valve full maintenance operation every **500,000 cycles or 5 years**, whichever comes first.

Client should consult the Habonim factory to obtain the product assessment, FMEDA report, and other associated statistical data to satisfy SIL level.

3. ATEX – Explosive Environment

The ball valves have been assessed as simple equipment within the assessment performed for the actuator. When used separately from the actuator, the ball valves shall be used within the parameters permitted for the actuator.

Habonim recommend replacing all bearings, seals, seats, and soft parts every **500,000 cycles or 5 years**, whichever comes first.

For valve actuation, actuated valves and more **ATEX** information please refer to the **Valves Actuation Assembly Guide**.

4. Valves marking and labeling

- 4.1. All valves marking is on a nameplate which is spot welded to the valve body or marked directly on the body.
- 4.2. Valves for the European market and above 1" carry the CE mark with the information required by the PED.
- 4.3. The valve markings that are according to API-6D standard are presented to provide the user full traceability and information regarding the valve. Unless otherwise requested, nameplates will be secured to the valve body and will be visible to the user. The information on the nameplate is as described below:

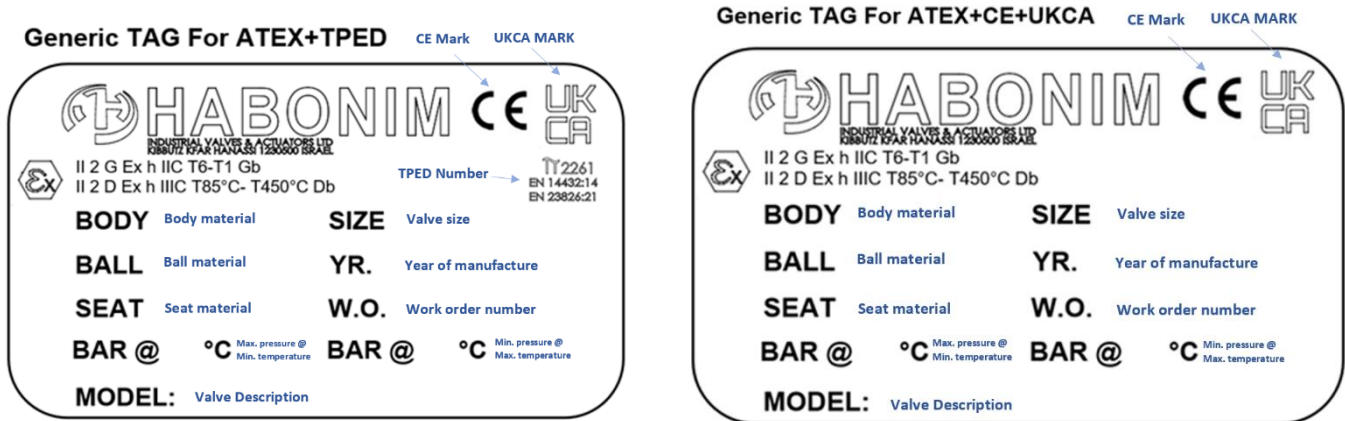

Gas Group Protection Markings

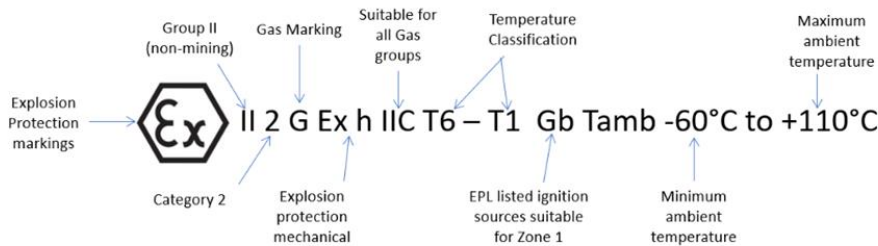

Dust Group Protection Markings

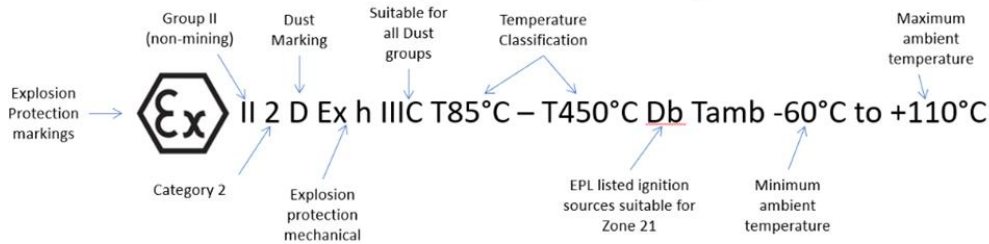

The manufacturer marks the temperature classification as T6 – T1 for Gas Group and T85°C to T450°C and the corresponding ambient temperatures. This is because the maximum surface temperature of the valves depends on the temperature of the medium (process fluid) that flows through the valve, see table below. It is therefore the responsibility of the user/installer to determine which values are applicable to their application.

Maximum Process Temperature (°C)	Associated Temperature Classification
80°C	T6 Zone 1 and T85°C Zone 21
95°C	T5 Zone 1 and T100°C Zone 21
130°C	T4 Zone 1 and T135°C Zone 21
190°C	T3 Zone 1 and T200°C Zone 21
290°C	T2 Zone 1 and T300°C Zone 21
440°C	T1 Zone 1 and T450°C Zone 21

Standard API-6D Tag

*Tag may be different then showed above depending on the application, region, registration etc.

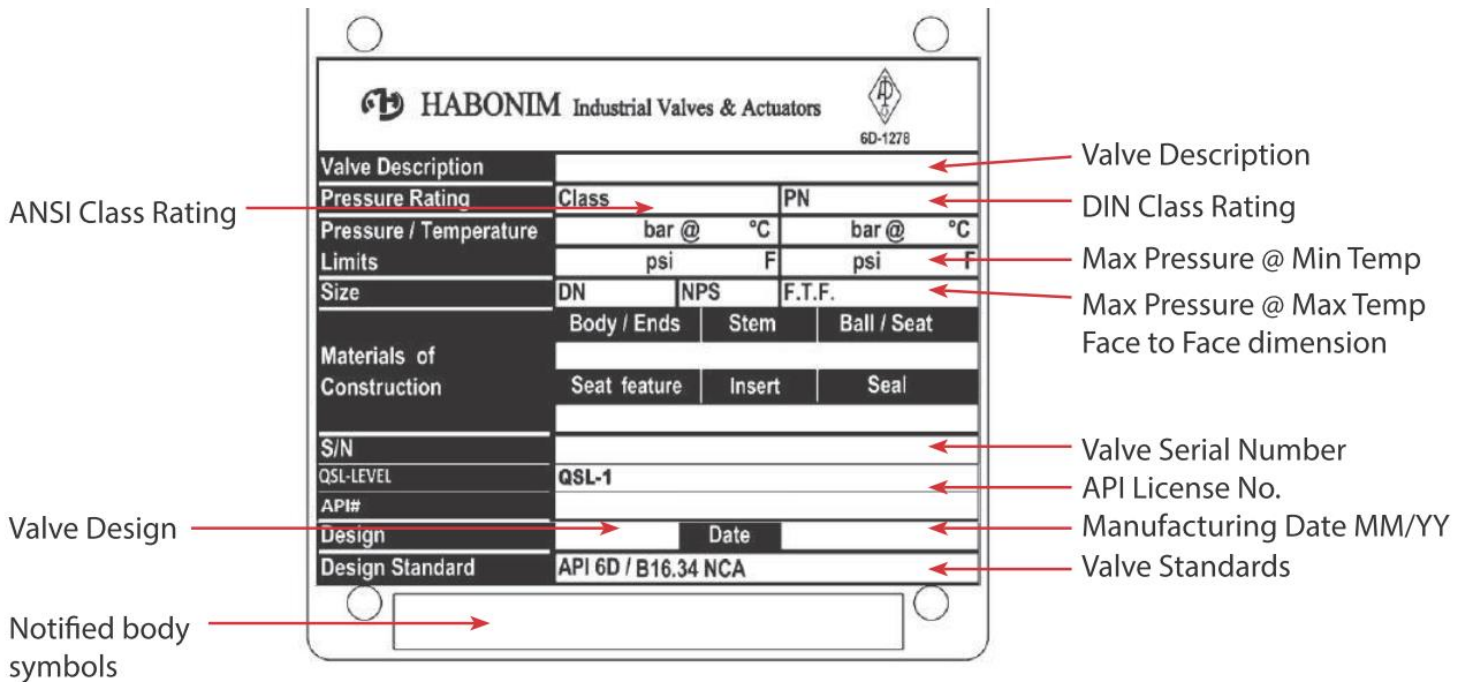

Standard Habonim Tag



5. Storage

Prior to storage, inspect the valve for shipping damage. Keep all protective packaging, flange covers, and end caps attached to the valves during storage. It is recommended to keep the valves in a clean and dry environment until they are ready for use.

Carbon Steel valves have a “black oxide” and oil dipped finish. This nontoxic process is performed to retard rusting during storage.

Black oxide is **not a substitute** for paint or other means of protective coating to be applied to the valve once installed.

Stainless steel valves have their natural finish and do not need any additional protection once installed.

6. Limitations

The correct selection of materials of construction, seats and seals, internal valve components and pressure/temperature ratings determines the safe use of the valves and the performance requirements for the application.

This information can be found on the name plate welded to the valve body.

WARNING: DO NOT EXCEED THE VALVE PERFORMANCE LIMITATIONS! EXCEEDING THE PRESSURE OR TEMPERATURE LIMITATIONS MARKED ON THE VALVE LABEL PLATE MAY CAUSE DAMAGE AND LEAD TO UNCONTROLLED PRESSURE RELEASE, DAMAGE OR PERSONAL INJURY MAY RESULT.

Habonim's standard valves design is for relative humidity of 50% and SATP (Standard Ambient Temperature and Pressure) environment conditions.

It is the owner's responsibility to use the valves as recommended and in accordance with the pressure/temperature limits and chemical compatibility for both inner & outer parts as stated in this manual.

If in doubt, please consult with Habonim.

Any unstable fluid or gas should be identified by its manufacturer and must not be used with Habonim valves.

CAUTION: The valves should be used in a well-designed, adequately protected system to ensure that external and internal pressure and temperature limits do not exceed the valve limits. The valve rating is defined as the lower rating of the seat and valve body. Valve surface temperature may become extremely hot or cold due to operating conditions. Prevent any type of direct contact with the valve that may cause harm or injury. Avoid direct contact with the valve by wearing protective gloves. The valves should be used in a well-designed, adequately supported piping system such that it will not be subjected to undue forces, stresses, or shock loads during service. The valves are not designed to operate during or after earthquakes or under fatigue conditions.

It is the responsibility of the owner to determine if fatigue conditions exist.

Do not allow dust layers to build up on the equipment.

The process fluid temperature shall not exceed the ignition temperature of the dust.

WARNING: USE OF THE VALVE IS APPLICATION SPECIFIC. BE SURE THAT THE VALVE IS SUITABLE FOR ITS INTENDED SERVICE. IF YOU HAVE ANY QUESTIONS CONCERNING THE USE, APPLICATION OR COMPATIBILITY OF THE VALVE WITH THE INTENDED SERVICE, CONTACT HABONIM FOR MORE INFORMATION.

6.1. Erosion allowance

The combined corrosion and erosion allowance for the valve body wall thickness is **1(mm)**. When this allowance has gone, the valve should no longer be used. Inspect the valve wall thickness every time the valve is maintained.

Refer to Habonim Chemical Compatibility Chart to determine the corrosion rate for your application. As the variety of applications these valves can be used in is large, it is impossible to cover all installation and maintenance instructions for servicing the valves.

6.2. Lubrication and greasing

A lubricant is applied to assist valve torque break in on all Habonim valves as a standard unless specified otherwise! The lubricant, if unacceptable, may be removed by disassembling the valve, a solvent wash and assembling it back.

For lubricant removal and recommended grease please refer to the [Disassembly and Assembly chapter](#).

7. Installation

The installation procedure for Habonim ball valves is critical to ensuring both long life and satisfying performance. Valves stored on site, awaiting installation, should be kept in their original packaging, in dry conditions, where damage will not occur (See [storage chapter](#)).

Before carrying out the installation, it is important to follow the basic procedures described below:

7.1. General

- 7.1.1. It is essential to flush the line prior to assembling any valve on the line.
- 7.1.2. Carefully unpack the valve and check valve [nameplate for identification of materials](#).
- 7.1.3. Remove any special packing materials surrounding the valve.
- 7.1.4. Check the valve for the [flow direction](#) indication marks. Appropriate care must be taken to install the valve for proper flow orientation.
- 7.1.5. Inspect the valve interior through the end ports to determine it is clean and free from foreign matter.
- 7.1.6. Cycle the valve and inspect any functionally significant features.
- 7.1.7. Read all the literature and note any special warning tags or plates attached to the valve.
- 7.1.8. Before installation check to ensure that the flow line balls are in the fully open position to prevent possible damage to the ball and seats. The valve performance depends on its original conditions. At any stage do not leave the valve in the partially open position on either of the lines.
- 7.1.9. If a shut-off valve is installed for end of line service, it must be ensured that it is closed with a blind end connection and the valve is secured against being opened unintentionally.

7.2. Installation of Uni-Directional valves

Habonim unidirectional valves must be installed for flow in one direction as indicated by the flow arrow welded on the valve body. **Usually, the arrow points to the shutoff direction of the valve.** In case of uncertainty related to direction. Relate to the arrowhead as the low-pressure side and the arrow tail as the high-pressure side ([Fig.A](#)).

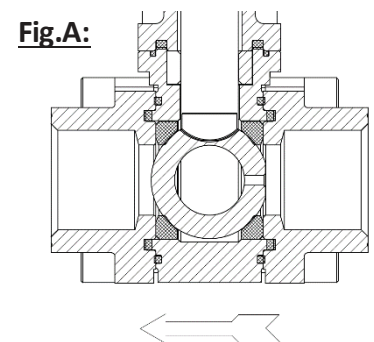

7.3. Installation in a vibrating environment

When installing a cryogenic valve with an actuator in a normal vibrating environment the whole unit **MUST** be fixed with a stable fixation to a rigid area.

When installing a cryogenic valve with an actuator in an **inclination angle it is CRITICAL** to do a stable fixation to the whole unit to a rigid area.

Note: The fixation MUST be made to the top of the valve bonnet - below the actuator.

For non-cryogenic valves it is **recommended** to do fixation in a normal vibrating environment. When installing a valve in a **high vibrating** environment such as for an off-road application - please contact Habonim.

7.4. Installation of threaded end valves

- 7.4.1. Valves with threaded ends should be treated as a single unit and should not be dismantled when installed to pipeline.
- 7.4.2. Before installing the valves, make sure that the threads on the mating pipe are free from excessive grit, dirt, or burrs.
- 7.4.3. When tightening the valve, apply a pipe wrench or spanner to the end connector closest to the pipe being worked, using standard piping practices.
- 7.4.4. Use appropriate joining sealants material in correct quantities.
- 7.4.5. If “back-welding” is required on threaded end valves, refer to the instructions for Weld End valves or to the “Habonim Welding Instructions” bulletin.

8. Operating Instructions

Habonim Valves provide tight shut off when used under normal conditions and in accordance with Habonim’s published pressure/temperature chart.

Habonim valves are designed to work only in a fully open or closed position. If the application requires to operate the valve in a partially open (throttled) position, please consult with Habonim!

WARNING: If these valves are used in a partially open (throttled) position, seat life may be reduced. Damage may occur to the seats which may lead to valve leakage.

On manual operated valves, the valve operation is done by turning the valve handle 90° counterclockwise to open (handle is parallel to flow line), and 90° clockwise to close (handle is perpendicular to flow line).

WARNING: Never look into the valve bore while the valve is in a flow line. Pressure and fluids could escape from the valve causing harm or injury.

9. Maintenance

HABONIM valves have a long and reliable life, and maintenance is seldom required. When maintenance is necessary, valves can be refurbished on site.

Habonim recommend replacing all bearings, seals, seats, and soft parts every **500,000 cycles or 5 years**, whichever comes first.

To extend valve performance and reduce possible plant problems, the following procedures should be followed:

- 9.1. If leakage around the stem is noticed, check the stem nut torque according to value in Table 1 in the Disassembly and assembly manual. If the leak continues, tighten the gland nut about a 1/4-turn as a routine maintenance procedure. This will compensate for any wear or settling of the gland packing.

Caution: Excessive tightening of the stem nut can result in accelerated seal wear and high valve operating torque.

- 9.2. It is **strongly recommended** to tighten the stem nut torque according to value in Table 1 in the disassembly and assembly manual every 15,000 cycles.

IMPORTANT: Up to 4 stem tightening operations every 15,000 cycles and 60,000 cycles in total are permitted.

Afterwards, all stem packing seals replacement is required (items 7,9 and 22) following the instructions in the disassembly and assembly manual.

- 9.3. If the valve is removed from the line and disassembled, replacement of all seats and seals is **required** by using the appropriate Habonim Repair kit. Examine all metallic sealing surfaces such as ball, stem, and the surfaces on the end connectors that contact the seats for wear, corrosion, or damage.
- 9.4. Only Habonim authorized spare parts should be used. Default repair kit parts from Habonim can be found at "components & materials" in Habonim catalog.
- 9.5. In addition to repair kits, other spare parts are available from Habonim, such as the stem, glands, bolts, screws, and nuts.
- 9.6. Should additional parts be required, it is recommended that the complete valve be replaced.
- 9.7. When ordering repair kits, please provide the valve size and full figure number code and series, engraved on the valve ID tag.

To prevent leakage, malfunctions resulting from internal wear or seal degradation, the user must establish a preventive maintenance and inspection program. This program must include:

- 1. Inspection of parts to detect loss of wall thickness which may result in decreased pressure capacity (see Para. "Limitations" - for acceptable reduction of wall thickness).**
- 2. Routine replacement of seals and inspection for proper operation.**

Valve operating torques, as published in the Habonim literature, are the normal expected maximum break-out torques. These torques have been confirmed by laboratory testing of each valve under controlled conditions. Highly viscous or abrasive media, frequency of operation and temperature fluctuations could cause an increase in valve torque.

10. Disassembly & Assembly Manual

10.1. General

- 10.1.1. It is strongly recommended to review both the disassembly and assembly chapters before getting started.
- 10.1.2. For stem thrusts/seals and threads Habonim recommends using **Molykote HP-870** or any equivalent grease.
- 10.1.3. For any discrepancies, please contact Habonim.

WARNING: Only lubricants that are compatible with the media and the valve may be applied.

10.2. Disassembly

- 10.2.1. Cycle the valve with the line pressure fully relieved before attempting to remove the valve from the pipeline, to ensure pressure has also been discharged from the valve cavity.
- 10.2.2. Set the valve to an open position.
- 10.2.3. Remove the body bolts pins.
- 10.2.4. Carefully remove the ends from the valve body.
- 10.2.5. Remove and discard the seats, body seals and all the valve parts.

WARNING: Be careful not to damage the sealing surfaces.

- 10.2.6. Set the valve to a close position.
- 10.2.7. Support the ball to prevent it from falling out of the valve body and set the ball aside in a clean secure area for reuse.
- 10.2.8. Remove the bonnet bolts and the bonnet from the top of the valve.
- 10.2.9. Remove stem nut and all the stem assembly components.
- 10.2.10. Place all the removed components in a clean and secure area.
- 10.2.11. Push the stem down into the body and remove it.
- 10.2.12. Discard the stem thrust seal, care taken not to scratch or nick the stem bore area of the body.
- 10.2.13. Clean the stem and the stem bore area.

10.3. Assembly

Bonnet and stem assembly for all valves sizes:

- 10.3.1. Lubricate the stem thrust seal (7), O-ring (22), bonnet O-ring (24) and the stem seal (9) with appropriate lubricant.
- 10.3.2. Insert the stem O-ring (22) and stem O-ring backup (22A) into the bonnet (26).
- 10.3.3. Place the stem thrust seal (7) on the stem (4).
- 10.3.4. Insert the stem (4) horizontally into bonnet (26) with the threaded side first and carefully guide it up through the stem bore.
- 10.3.5. Holding the stem (4) up insert the stem seal (9) over the stem (4) and into the stem bore. Place the anti-abrasion ring (7A), follower (10), two-disc springs (11), and Thread the stem nut (12) onto the stem (4).
- 10.3.6. Place the bonnet seal (24B), bonnet O-ring (24) and the bonnet OR backup (24A) into the bonnet (26).
- 10.3.7. Inset the bonnet FS seal (24C) and the Stem bearing (25) into the valve body.
- 10.3.8. Place the assembled bonnet (26) on the top of the valve body (1) and hand tighten the bonnet bolts (28).
- 10.3.9. Tighten the stem nut onto the stem according to **table 1**.
- 10.3.10. Add the locking clip (13).
- 10.3.11. Tighten the bonnet bolts according to **table 1**.

Detail B – Stem & Bonnet Section View

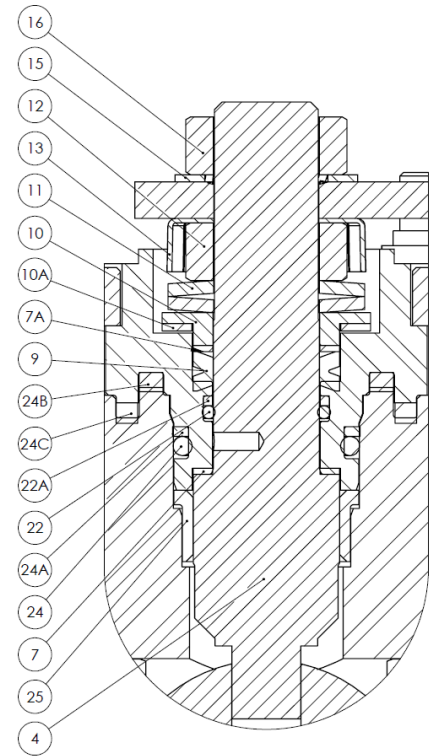

Table 1:

Valve Size	Stem Nut Tightening Torque		Bonnet Bolts Tightening Torque			Ends Bolts Tightening Torque		
	N-m	[Lb-in]	Bolts	Nm	Lb-In	Bolts	Nm	Lb-In
¼" -1"	15	133	M8	30-35	265-310	M12	100-120	885-1062
1-1/4"-2"	60	530	M12	100-120	885-1062	M20	820-915	7258-8100

Important: An excessively tightened stem nut can cause excessive packing wear and increase stem torque.

- 10.3.12. Place the handle (14), serrated washer (15) and the handle nut (16) on top of the stem (4).
- 10.3.13. Tighten the handle nut (16) onto the stem (4) according to **table 1**.
- 10.3.14. Place the stop plate (14A) on top of the valve body (1).
- 10.3.15. Insert the stop pins (8A) through the spring washers (8A) into the stop plate (14A).
- 10.3.16. Hand tight the stop pins (8A) on top of the body.

Seals and seats assembly for all valves sizes:

- 10.3.17. Bring the valve to a close position and insert the ball (3).
- 10.3.18. Place the ball into the valve body (1) until the stem tongue is engaged and turn the stem so the valve is at an open position, to prevent the ball from falling out.
- 10.3.19. **Recommended:** If applicable lubricate the ball and seats with appropriate grease.
- 10.3.20. Place the seat seal (5A) between the two-seat seal backup (5B) on the seat (5) groove.
- 10.3.21. Assemble the housing FS seal (5H), inner seal (6) and the seat spring (5C) into the back of the seat (5).
- 10.3.22. Insert the outer seal (6A) into the valve body (1).
- 10.3.23. Place the assembled seats (5) into the valve body.

Detail C – Seat Section View

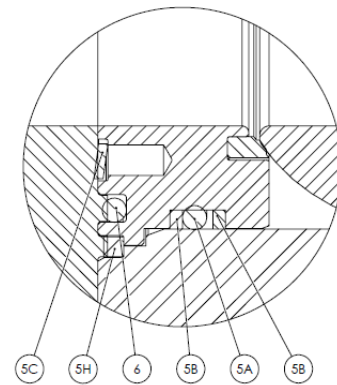

Valve body and end connectors assembly for all valves sizes:

- 10.3.24. To prevent galling of threads of the bolts or nuts, lubricate threads with an anti-galling compound.
- 10.3.25. Ease back the body assembly between end connectors (2), taking care not to score faces or damage seals, and reinstall body bolts (18).
- 10.3.26. Apply initial tightening of the body bolts according to tightening sequence as illustrated:

Sizes ¼" - 1"

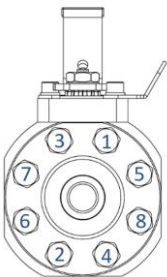

Sizes 1¼" - 2"

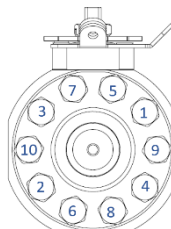

- 10.3.27. Tighten the body bolts according to **table 1:**
- 10.3.28. Set the valve to the open position.

Valve Section View:

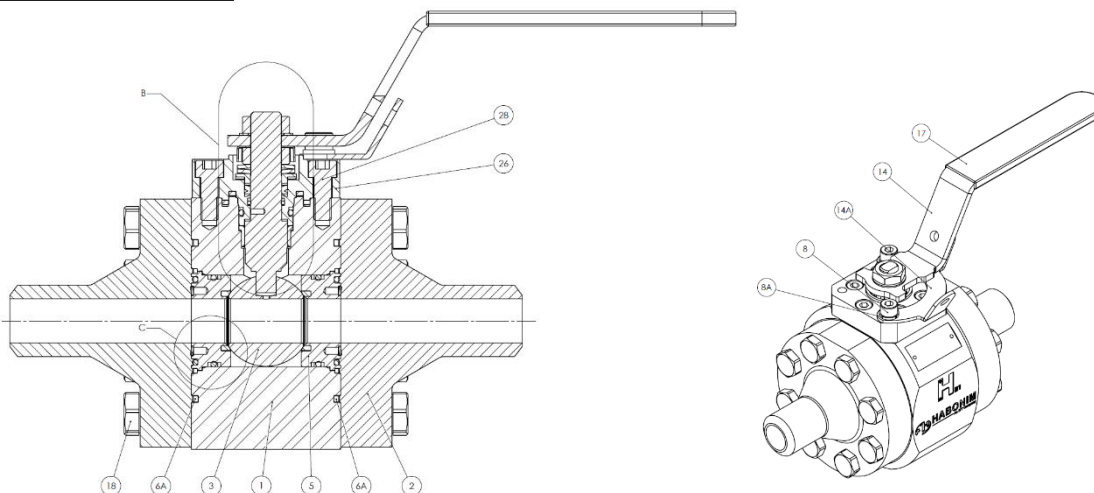

Components and materials:

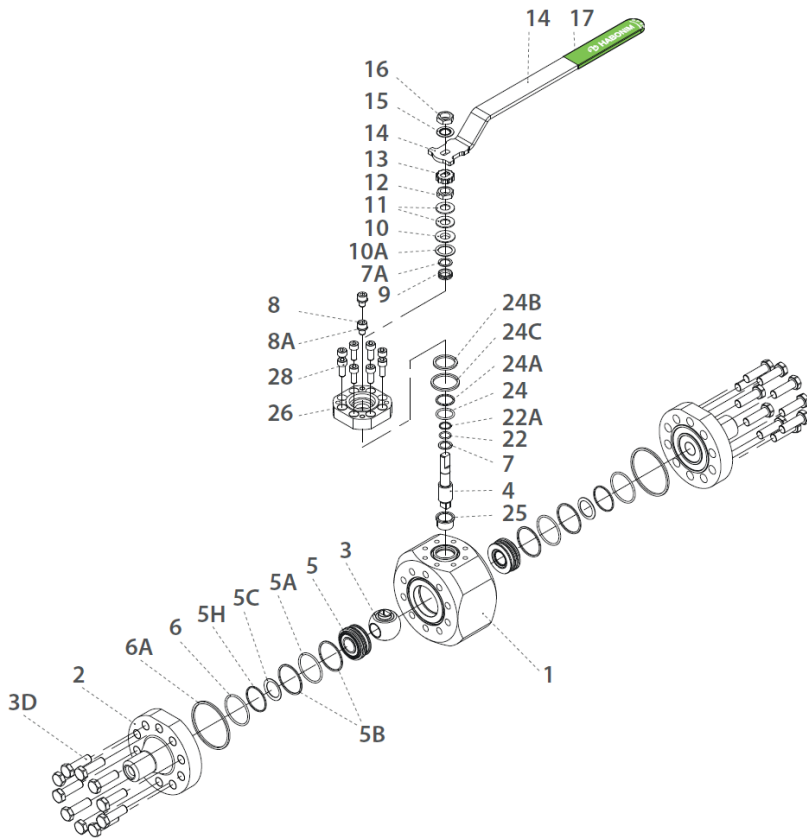

Item	Description	Material specification	Qty.
1	Body Acc.	Ordering Code	
2	Ends Acc.	Ordering Code	2
3	Ball Acc.	Ordering Code	
4	Acc. Ordering	Code	1
5	Seat	S. steel + V. peek	2
5A	Seat seal	Acc. Ordering Code	2
5B	Seat seal backup	V. peek	4
5C	Seat spring	Inconel 718	
5H	Housing FS seal	Graphit 2	1
6	Inner seal	Acc. Ordering Code	2
6A	Outer seal	Acc. Ordering Code	2
7	Stem thrust seal	V. peek, PCTFE	1
7A	Anti-abrasion ring	V. peek, PCTFE	1
8	Stop pin	S. steel	2
8A	Spring washer	S. steel	2
9	Stem seal	CF PTFE, TFM	1
10	Follower	S. steel	1
10A	Slide bearing	S. steel	1
11	Disc spring	S. steel	2
12	Stem nut	S. steel	1
13	Locking clip	S. steel	1
14	Handle	S. steel	1
15	Serrated washer	S. steel	1
16	Handle nut	S. steel	1
17	Sleeve	PVC	1
18	Body bold	S. steel	20
22	Stem OR	Acc. Ordering Code	1
22A	Stem OR backup	V. peek	1
24	Bonnet OR	Acc. Ordering Code	1
24A	Bonnet OR backup	V. peek	1
24B	Boonet seal	TFM	1
24C	Boonet FS seal	Graphite 1	
25	Stem bearing	PTFE	1
26	Bonnet	S. steel	1
28	Bolt	S. steel	8