

# Technical information Flange dimensions



## Flange dimensions

ANSI B16.5

DIN EN1092

### ANSI B16.5 | Class 150

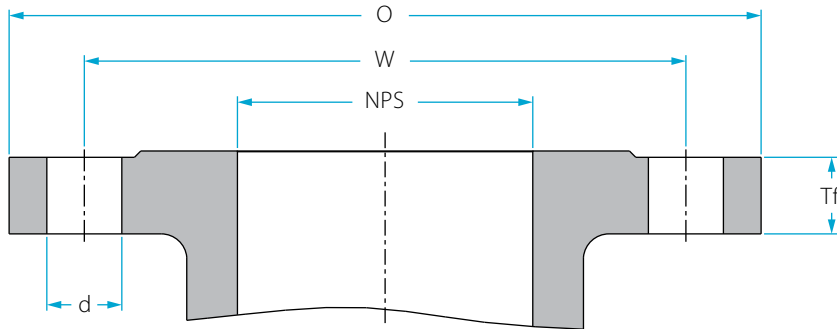

| NPS<br>Nominal<br>Pipe Size | O      |       | W      |       | Tf    |      | d     |       | Number<br>holes |
|-----------------------------|--------|-------|--------|-------|-------|------|-------|-------|-----------------|
|                             | mm     | inch  | mm     | inch  | mm    | inch | mm    | inch  |                 |
| 1/2"                        | 90.00  | 3.54  | 60.30  | 2.37  | 9.60  | 0.38 | 15.88 | 5/8   | 4               |
| 3/4"                        | 100.00 | 3.94  | 69.90  | 2.75  | 11.20 | 0.44 | 15.88 | 5/8   | 4               |
| 1"                          | 110.00 | 4.33  | 79.40  | 3.13  | 12.70 | 0.50 | 15.88 | 5/8   | 4               |
| 1 1/4"                      | 115.00 | 4.53  | 88.90  | 3.50  | 14.30 | 0.56 | 15.88 | 5/8   | 4               |
| 1 1/2"                      | 125.00 | 4.92  | 98.40  | 3.87  | 15.90 | 0.63 | 15.88 | 5/8   | 4               |
| 2"                          | 150.00 | 5.91  | 120.70 | 4.75  | 17.50 | 0.69 | 19.05 | 3/4   | 4               |
| 2 1/2"                      | 180.00 | 7.09  | 139.70 | 5.50  | 20.70 | 0.81 | 19.05 | 3/4   | 4               |
| 3"                          | 190.00 | 7.48  | 152.40 | 6.00  | 22.30 | 0.88 | 19.05 | 3/4   | 4               |
| 3 1/2"                      | 215.00 | 8.46  | 177.80 | 7.00  | 22.30 | 0.88 | 19.05 | 3/4   | 8               |
| 4"                          | 230.00 | 9.06  | 190.50 | 7.50  | 22.30 | 0.88 | 19.05 | 3/4   | 8               |
| 5"                          | 255.00 | 10.04 | 215.90 | 8.50  | 22.30 | 0.88 | 22.23 | 7/8   | 8               |
| 6"                          | 280.00 | 11.02 | 241.30 | 9.50  | 23.90 | 0.94 | 22.23 | 7/8   | 8               |
| 8"                          | 345.00 | 13.58 | 298.50 | 11.75 | 27.00 | 1.06 | 22.23 | 7/8   | 8               |
| 10"                         | 405.00 | 15.94 | 362.00 | 14.25 | 28.60 | 1.13 | 25.40 | 1     | 12              |
| 12"                         | 485.00 | 19.09 | 431.80 | 17.00 | 30.20 | 1.19 | 25.40 | 1     | 12              |
| 14"                         | 535.00 | 21.06 | 476.30 | 18.75 | 33.40 | 1.31 | 28.58 | 1 1/8 | 12              |
| 16"                         | 595.00 | 23.43 | 539.80 | 21.25 | 35.00 | 1.38 | 28.58 | 1 1/8 | 16              |
| 18"                         | 635.00 | 25.00 | 577.90 | 22.75 | 38.10 | 1.50 | 31.75 | 1 1/4 | 16              |
| 20"                         | 700.00 | 27.56 | 635.00 | 25.00 | 41.30 | 1.63 | 31.75 | 1 1/4 | 20              |
| 24"                         | 815.00 | 32.09 | 749.30 | 29.50 | 46.10 | 1.81 | 31.75 | 1 3/8 | 20              |

ANSI B16.5 | Class 300

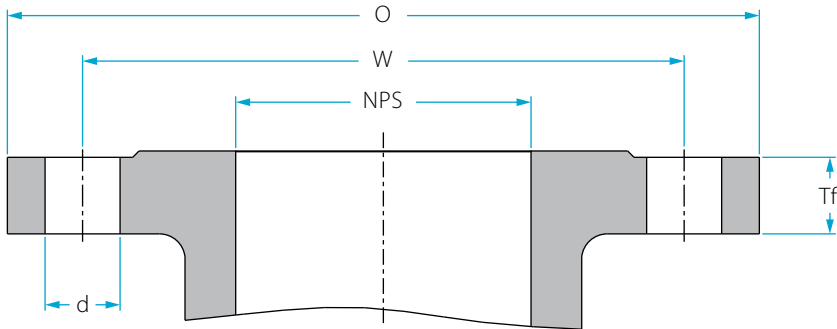

| NPS<br>Nominal<br>Pipe Size | O      |       | W      |       | Tf    |      | d     |       | Number<br>holes |
|-----------------------------|--------|-------|--------|-------|-------|------|-------|-------|-----------------|
|                             | mm     | inch  | mm     | inch  | mm    | inch | mm    | inch  |                 |
| 1/2"                        | 95.00  | 3.74  | 66.70  | 2.63  | 12.70 | 0.50 | 15.88 | 5/8   | 4               |
| 3/4"                        | 115.00 | 4.53  | 82.60  | 3.25  | 14.30 | 0.56 | 19.05 | 3/4   | 4               |
| 1"                          | 125.00 | 4.92  | 88.90  | 3.50  | 15.90 | 0.63 | 19.05 | 3/4   | 4               |
| 1 1/4"                      | 135.00 | 5.31  | 98.40  | 3.87  | 17.50 | 0.69 | 19.05 | 3/4   | 4               |
| 1 1/2"                      | 155.00 | 6.10  | 114.30 | 4.50  | 19.10 | 0.75 | 22.23 | 7/8   | 4               |
| 2"                          | 165.00 | 6.50  | 127.00 | 5.00  | 20.70 | 0.81 | 19.05 | 5/8   | 8               |
| 2 1/2"                      | 190.00 | 7.48  | 149.20 | 5.87  | 23.90 | 0.94 | 22.23 | 5/8   | 8               |
| 3"                          | 210.00 | 8.27  | 168.30 | 6.63  | 27.00 | 1.06 | 22.23 | 5/8   | 8               |
| 3 1/2"                      | 230.00 | 9.06  | 184.20 | 7.25  | 28.60 | 1.13 | 22.23 | 5/8   | 8               |
| 4"                          | 255.00 | 10.04 | 200.00 | 7.87  | 30.20 | 1.19 | 22.23 | 5/8   | 8               |
| 5"                          | 280.00 | 11.02 | 235.00 | 9.25  | 33.40 | 1.31 | 22.23 | 5/8   | 8               |
| 6"                          | 320.00 | 12.60 | 269.90 | 10.63 | 35.00 | 1.38 | 22.23 | 5/8   | 12              |
| 8"                          | 380.00 | 14.96 | 330.20 | 13.00 | 39.70 | 1.56 | 25.40 | 1     | 12              |
| 10"                         | 445.00 | 17.52 | 387.40 | 15.25 | 46.10 | 1.81 | 28.58 | 1 1/8 | 16              |
| 12"                         | 520.00 | 20.47 | 450.80 | 17.75 | 49.30 | 1.94 | 31.75 | 1 1/4 | 16              |
| 14"                         | 585.00 | 23.03 | 514.40 | 20.25 | 52.40 | 2.06 | 31.75 | 1 1/4 | 20              |
| 16"                         | 650.00 | 25.59 | 571.50 | 22.50 | 55.60 | 2.19 | 34.93 | 1 3/8 | 20              |
| 18"                         | 710.00 | 27.95 | 628.60 | 24.75 | 58.80 | 2.31 | 34.93 | 1 3/8 | 24              |
| 20"                         | 775.00 | 30.51 | 685.80 | 27.00 | 62.00 | 2.44 | 34.93 | 1 3/8 | 24              |
| 24"                         | 915.00 | 36.02 | 812.80 | 32.00 | 68.30 | 2.69 | 41.28 | 1 5/8 | 24              |

## Flange dimensions

ANSI B16.5

DIN EN1092

### ANSI B16.5 | Class 400

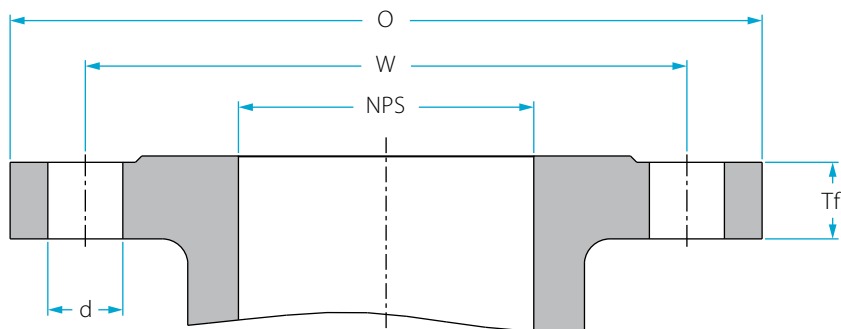

| NPS<br>Nominal<br>Pipe Size | O      |       | W      |       | Tf    |      | d     |       | Number<br>holes |
|-----------------------------|--------|-------|--------|-------|-------|------|-------|-------|-----------------|
|                             | mm     | inch  | mm     | inch  | mm    | inch | mm    | inch  |                 |
| 1/2"                        | 95.00  | 3.74  | 66.70  | 2.63  | 14.30 | 0.56 | 15.88 | 5/8   | 4               |
| 3/4"                        | 115.00 | 4.53  | 82.60  | 3.25  | 15.90 | 0.63 | 19.05 | 3/4   | 4               |
| 1"                          | 125.00 | 4.92  | 88.90  | 3.50  | 17.50 | 0.69 | 19.05 | 3/4   | 4               |
| 1 1/4"                      | 135.00 | 5.31  | 98.40  | 3.87  | 20.70 | 0.81 | 19.05 | 3/4   | 4               |
| 1 1/2"                      | 155.00 | 6.10  | 114.30 | 4.50  | 22.30 | 0.88 | 22.23 | 7/8   | 4               |
| 2"                          | 165.00 | 6.50  | 127.00 | 5.00  | 25.40 | 1.00 | 19.05 | 3/4   | 8               |
| 2 1/2"                      | 190.00 | 7.48  | 149.20 | 5.87  | 28.60 | 1.13 | 22.23 | 7/8   | 8               |
| 3"                          | 210.00 | 8.27  | 168.30 | 6.63  | 31.80 | 1.25 | 22.23 | 7/8   | 8               |
| 3 1/2"                      | 230.00 | 9.06  | 184.20 | 7.25  | 35.00 | 1.38 | 25.40 | 1     | 8               |
| 4"                          | 255.00 | 10.04 | 200.00 | 7.87  | 35.00 | 1.38 | 25.40 | 1     | 8               |
| 5"                          | 280.00 | 11.02 | 235.00 | 9.25  | 38.10 | 1.50 | 25.40 | 1     | 8               |
| 6"                          | 320.00 | 12.60 | 269.90 | 10.63 | 41.30 | 1.63 | 25.40 | 1     | 12              |
| 8"                          | 380.00 | 14.96 | 330.00 | 12.99 | 47.70 | 1.88 | 28.58 | 1 1/8 | 12              |
| 10"                         | 445.00 | 17.52 | 387.40 | 15.25 | 54.00 | 2.13 | 31.75 | 1 1/4 | 16              |
| 12"                         | 520.00 | 20.47 | 450.80 | 17.75 | 57.20 | 2.25 | 34.93 | 1 3/8 | 16              |
| 14"                         | 585.00 | 23.03 | 514.40 | 20.25 | 60.40 | 2.38 | 34.93 | 1 3/8 | 20              |
| 16"                         | 650.00 | 25.59 | 571.50 | 22.50 | 63.50 | 2.50 | 38.10 | 1 1/2 | 20              |
| 18"                         | 710.00 | 27.95 | 628.60 | 24.75 | 66.70 | 2.63 | 38.10 | 1 1/2 | 24              |
| 20"                         | 775.00 | 30.51 | 685.80 | 27.00 | 69.90 | 2.75 | 41.28 | 1 5/8 | 24              |
| 24"                         | 915.00 | 36.02 | 812.80 | 32.00 | 76.20 | 3.00 | 47.63 | 1 7/8 | 24              |

ANSI B16.5 | Class 600

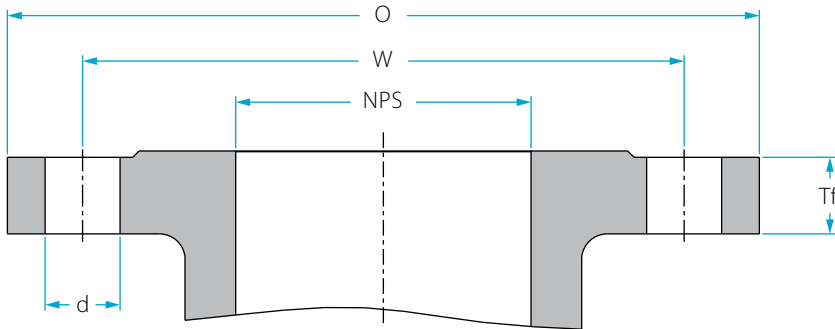

| NPS<br>Nominal<br>Pipe Size | O      |       | W      |       | Tf     |      | d     |       | Number<br>holes |
|-----------------------------|--------|-------|--------|-------|--------|------|-------|-------|-----------------|
|                             | mm     | inch  | mm     | inch  | mm     | inch | mm    | inch  |                 |
| 1/2"                        | 95.00  | 3.74  | 66.70  | 2.63  | 14.30  | 0.56 | 15.88 | 5/8   | 4               |
| 3/4"                        | 115.00 | 4.53  | 82.60  | 3.25  | 15.90  | 0.63 | 19.05 | 3/4   | 4               |
| 1"                          | 125.00 | 4.92  | 88.90  | 3.50  | 17.50  | 0.69 | 19.05 | 3/4   | 4               |
| 1 1/4"                      | 135.00 | 5.31  | 98.40  | 3.87  | 20.70  | 0.81 | 19.05 | 3/4   | 4               |
| 1 1/2"                      | 155.00 | 6.10  | 114.30 | 4.50  | 22.30  | 0.88 | 22.23 | 7/8   | 4               |
| 2"                          | 165.00 | 6.50  | 127.00 | 5.00  | 25.40  | 1.00 | 19.05 | 3/4   | 8               |
| 2 1/2"                      | 190.00 | 7.48  | 149.20 | 5.87  | 28.60  | 1.13 | 22.23 | 7/8   | 8               |
| 3"                          | 210.00 | 8.27  | 168.30 | 6.63  | 31.80  | 1.25 | 22.23 | 7/8   | 8               |
| 3 1/2"                      | 230.00 | 9.06  | 184.20 | 7.25  | 35.00  | 1.38 | 25.40 | 1     | 8               |
| 4"                          | 275.00 | 10.83 | 215.90 | 8.50  | 38.10  | 1.50 | 25.40 | 1     | 8               |
| 5"                          | 330.00 | 12.99 | 266.70 | 10.50 | 44.50  | 1.75 | 28.58 | 1 1/8 | 8               |
| 6"                          | 355.00 | 13.98 | 292.10 | 11.50 | 47.70  | 1.88 | 28.58 | 1 1/8 | 12              |
| 8"                          | 420.00 | 16.54 | 349.20 | 13.75 | 55.60  | 2.19 | 31.75 | 1 1/4 | 12              |
| 10"                         | 510.00 | 20.08 | 431.80 | 17.00 | 63.50  | 2.50 | 34.93 | 1 3/8 | 16              |
| 12"                         | 560.00 | 22.05 | 489.00 | 19.25 | 66.70  | 2.63 | 34.93 | 1 3/8 | 20              |
| 14"                         | 605.00 | 23.82 | 527.00 | 20.75 | 69.90  | 2.75 | 38.10 | 1 1/2 | 20              |
| 16"                         | 685.00 | 26.97 | 603.20 | 23.75 | 76.20  | 3.00 | 41.28 | 1 5/8 | 20              |
| 18"                         | 745.00 | 29.33 | 654.00 | 25.75 | 82.60  | 3.25 | 44.45 | 1 3/4 | 20              |
| 20"                         | 815.00 | 32.09 | 723.90 | 28.50 | 88.90  | 3.50 | 44.45 | 1 3/4 | 24              |
| 24"                         | 940.00 | 37.01 | 838.20 | 33.00 | 101.60 | 4.00 | 50.80 | 2     | 24              |

## Flange dimensions

ANSI B16.5

DIN EN1092

### ANSI B16.5 | Class 900

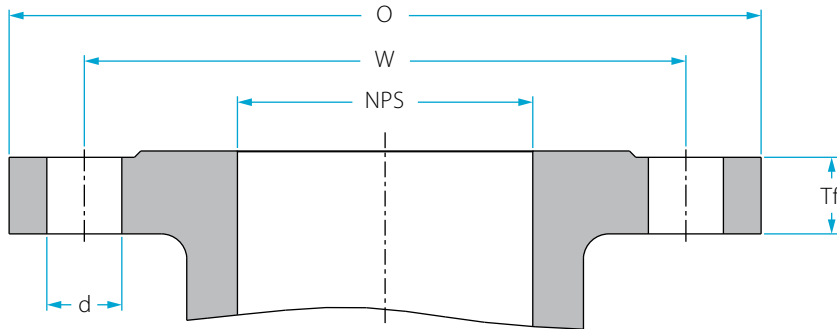

| NPS<br>Nominal<br>Pipe Size | O        |       | W      |       | Tf     |      | d     |       | Number<br>holes |
|-----------------------------|----------|-------|--------|-------|--------|------|-------|-------|-----------------|
|                             | mm       | inch  | mm     | inch  | mm     | inch | mm    | inch  |                 |
| 1/2"                        | 120.00   | 4.72  | 82.60  | 3.25  | 22.30  | 0.88 | 22.23 | 7/8   | 4               |
| 3/4"                        | 130.00   | 5.12  | 88.90  | 3.50  | 25.40  | 1.00 | 22.23 | 7/8   | 4               |
| 1"                          | 150.00   | 5.91  | 101.60 | 4.00  | 28.60  | 1.13 | 25.40 | 1     | 4               |
| 1 1/4"                      | 160.00   | 6.30  | 111.10 | 4.37  | 28.60  | 1.13 | 25.40 | 1     | 4               |
| 1 1/2"                      | 180.00   | 7.09  | 123.80 | 4.87  | 31.80  | 1.25 | 28.58 | 1 1/8 | 4               |
| 2"                          | 215.00   | 8.46  | 165.10 | 6.50  | 38.10  | 1.50 | 25.40 | 1     | 8               |
| 2 1/2"                      | 245.00   | 9.65  | 190.50 | 7.50  | 41.30  | 1.63 | 28.58 | 1 1/8 | 8               |
| 3"                          | 240.00   | 9.45  | 190.50 | 7.50  | 38.10  | 1.50 | 25.40 | 1     | 8               |
| 4"                          | 290.00   | 11.42 | 235.00 | 9.25  | 44.50  | 1.75 | 31.75 | 1 1/4 | 8               |
| 5"                          | 350.00   | 13.78 | 279.40 | 11.00 | 50.80  | 2.00 | 34.93 | 1 3/8 | 8               |
| 6"                          | 380.00   | 14.96 | 317.50 | 12.50 | 55.60  | 2.19 | 31.75 | 1 1/4 | 12              |
| 8"                          | 470.00   | 18.50 | 393.70 | 15.50 | 63.50  | 2.50 | 38.10 | 1 1/2 | 12              |
| 10"                         | 545.00   | 21.46 | 469.90 | 18.50 | 69.90  | 2.75 | 38.10 | 1 1/2 | 16              |
| 12"                         | 610.00   | 24.02 | 533.40 | 21.00 | 79.40  | 3.13 | 38.10 | 1 1/2 | 20              |
| 14"                         | 640.00   | 25.20 | 558.80 | 22.00 | 85.80  | 3.38 | 41.28 | 1 5/8 | 20              |
| 16"                         | 705.00   | 27.76 | 616.00 | 24.25 | 88.90  | 3.50 | 44.45 | 1 3/4 | 20              |
| 18"                         | 785.00   | 30.91 | 685.80 | 27.00 | 101.60 | 4.00 | 50.80 | 2     | 20              |
| 20"                         | 855.00   | 33.66 | 749.30 | 29.50 | 108.00 | 4.25 | 53.98 | 2 1/8 | 20              |
| 24"                         | 1,040.00 | 40.94 | 901.70 | 35.50 | 139.70 | 5.50 | 66.68 | 2 5/8 | 20              |

ANSI B16.5 | Class 1500

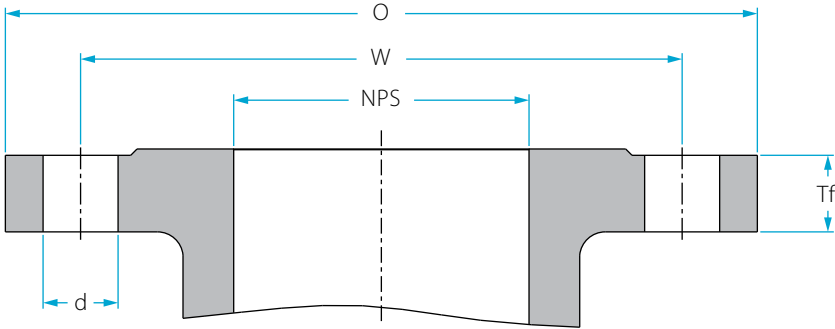

| NPS<br>Nominal<br>Pipe Size | O       |       | W      |       | Tf     |      | d     |       | Number<br>holes |
|-----------------------------|---------|-------|--------|-------|--------|------|-------|-------|-----------------|
|                             | mm      | inch  | mm     | inch  | mm     | inch | mm    | inch  |                 |
| 1/2"                        | 120.00  | 4.72  | 82.60  | 3.25  | 22.30  | 0.88 | 22.23 | 7/8   | 4               |
| 3/4"                        | 130.00  | 5.12  | 88.90  | 3.50  | 25.40  | 1.00 | 22.23 | 7/8   | 4               |
| 1"                          | 150.00  | 5.91  | 101.60 | 4.00  | 28.60  | 1.13 | 25.40 | 1     | 4               |
| 1 1/4"                      | 160.00  | 6.30  | 111.10 | 4.37  | 28.60  | 1.13 | 25.40 | 1     | 4               |
| 1 1/2"                      | 180.00  | 7.09  | 123.80 | 4.87  | 31.80  | 1.25 | 28.58 | 1 1/8 | 4               |
| 2"                          | 215.00  | 8.46  | 165.10 | 6.50  | 38.10  | 1.50 | 25.40 | 1     | 8               |
| 2 1/2"                      | 245.00  | 9.65  | 190.50 | 7.50  | 41.30  | 1.63 | 28.58 | 1 1/8 | 8               |
| 3"                          | 265.00  | 10.43 | 203.20 | 8.00  | 47.70  | 1.88 | 31.75 | 1 1/4 | 8               |
| 4"                          | 310.00  | 12.20 | 241.30 | 9.50  | 54.00  | 2.13 | 34.93 | 1 3/8 | 8               |
| 5"                          | 375.00  | 14.76 | 292.10 | 11.50 | 73.10  | 2.88 | 41.28 | 1 5/8 | 8               |
| 6"                          | 395.00  | 15.55 | 317.50 | 12.50 | 82.60  | 3.25 | 38.10 | 1 1/2 | 12              |
| 8"                          | 485.00  | 19.09 | 393.70 | 15.50 | 92.10  | 3.63 | 44.45 | 1 3/4 | 12              |
| 10"                         | 585.00  | 23.03 | 482.60 | 19.00 | 108.00 | 4.25 | 50.80 | 2     | 12              |
| 12"                         | 675.00  | 26.57 | 571.50 | 22.50 | 123.90 | 4.88 | 53.98 | 2 1/8 | 16              |
| 14"                         | 750.00  | 29.53 | 635.00 | 25.00 | 133.40 | 5.25 | 60.33 | 2 3/8 | 16              |
| 16"                         | 825.00  | 32.48 | 704.80 | 27.75 | 146.10 | 5.75 | 66.68 | 2 5/8 | 16              |
| 18"                         | 915.00  | 36.02 | 774.70 | 30.50 | 162.00 | 6.38 | 73.03 | 2 7/8 | 16              |
| 20"                         | 985.00  | 38.78 | 831.80 | 32.75 | 177.80 | 7.00 | 79.38 | 3 1/8 | 16              |
| 24"                         | 1170.00 | 46.06 | 990.60 | 39.00 | 203.20 | 8.00 | 92.08 | 3 5/8 | 16              |

## Flange dimensions

ANSI B16.5

DIN EN1092

### ANSI B16.5 | Class 2500

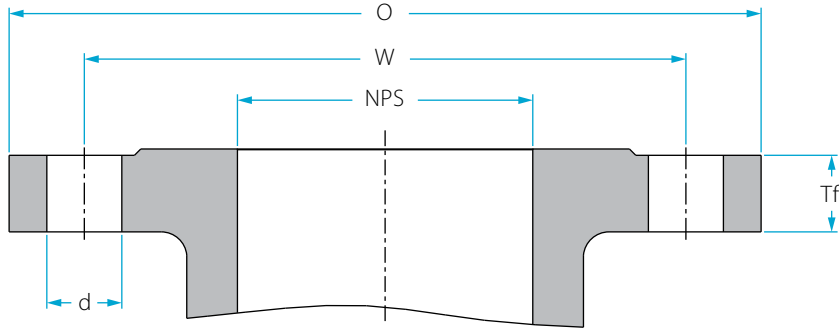

| NPS<br>Nominal<br>Pipe Size | O      |       | W      |       | Tf     |      | d     |       | Number<br>holes |
|-----------------------------|--------|-------|--------|-------|--------|------|-------|-------|-----------------|
|                             | mm     | inch  | mm     | inch  | mm     | inch | mm    | inch  |                 |
| 1/2"                        | 135.00 | 5.31  | 88.90  | 3.50  | 30.20  | 1.19 | 22.23 | 7/8   | 4               |
| 3/4"                        | 140.00 | 5.51  | 95.20  | 3.75  | 31.80  | 1.25 | 22.23 | 7/8   | 4               |
| 1"                          | 160.00 | 6.30  | 108.00 | 4.25  | 35.00  | 1.38 | 25.40 | 1     | 4               |
| 1 1/4"                      | 185.00 | 7.28  | 130.20 | 5.13  | 38.10  | 1.50 | 28.58 | 1 1/8 | 4               |
| 1 1/2"                      | 205.00 | 8.07  | 146.00 | 5.75  | 44.50  | 1.75 | 31.75 | 1 1/4 | 4               |
| 2"                          | 235.00 | 9.25  | 171.40 | 6.75  | 50.90  | 2.00 | 28.58 | 1 1/8 | 8               |
| 2 1/2"                      | 265.00 | 10.43 | 196.80 | 7.75  | 57.20  | 2.25 | 31.75 | 1 1/4 | 8               |
| 3"                          | 305.00 | 12.01 | 228.60 | 9.00  | 66.70  | 2.63 | 34.93 | 1 3/8 | 8               |
| 4"                          | 355.00 | 13.98 | 273.00 | 10.75 | 76.20  | 3.00 | 41.28 | 1 5/8 | 8               |
| 5"                          | 420.00 | 16.54 | 323.80 | 12.75 | 92.10  | 3.63 | 47.63 | 1 7/8 | 8               |
| 6"                          | 485.00 | 19.09 | 368.30 | 14.50 | 108.00 | 4.25 | 53.98 | 2 1/8 | 8               |
| 8"                          | 550.00 | 21.65 | 438.20 | 17.25 | 127.00 | 5.00 | 53.98 | 2 1/8 | 12              |
| 10"                         | 675.00 | 26.57 | 539.80 | 21.25 | 165.10 | 6.50 | 66.68 | 2 5/8 | 12              |
| 12"                         | 760.00 | 29.92 | 619.10 | 24.37 | 184.20 | 7.25 | 73.03 | 2 7/8 | 12              |



Flange dimensions

ANSI B16.5

DIN EN1092

DIN EN1092 | DIN PN10

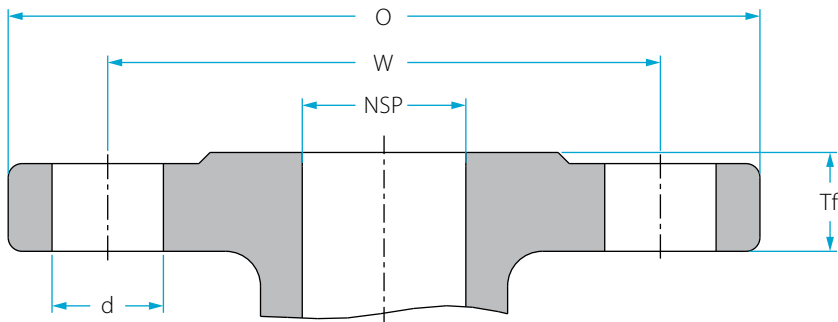

| NPS<br>Nominal<br>Pipe Size | O      |       | W      |       | Tf    |      | d     |        | Number<br>holes |
|-----------------------------|--------|-------|--------|-------|-------|------|-------|--------|-----------------|
|                             | mm     | inch  | mm     | inch  | mm    | inch | mm    | inch   |                 |
| 10                          | 90.00  | 3.54  | 60.00  | 2.36  | 16.00 | 0.63 | 14.00 | 5/8    | 4               |
| 15                          | 95.00  | 3.74  | 65.00  | 2.56  | 16.00 | 0.63 | 14.00 | 5/8    | 4               |
| 20                          | 105.00 | 4.13  | 75.00  | 2.95  | 18.00 | 0.71 | 14.00 | 5/8    | 4               |
| 25                          | 115.00 | 4.53  | 85.00  | 3.35  | 18.00 | 0.71 | 14.00 | 5/8    | 4               |
| 32                          | 140.00 | 5.51  | 100.00 | 3.94  | 18.00 | 0.71 | 18.00 | 5/7    | 4               |
| 40                          | 150.00 | 5.91  | 110.00 | 4.33  | 18.00 | 0.71 | 18.00 | 5/7    | 4               |
| 50                          | 165.00 | 6.50  | 125.00 | 4.92  | 18.00 | 0.71 | 18.00 | 5/7    | 4               |
| 65                          | 185.00 | 7.28  | 145.00 | 5.71  | 18.00 | 0.71 | 18.00 | 5/7    | 8               |
| 80                          | 200.00 | 7.87  | 160.00 | 6.30  | 20.00 | 0.79 | 18.00 | 5/7    | 8               |
| 100                         | 220.00 | 8.66  | 180.00 | 7.09  | 20.00 | 0.79 | 18.00 | 5/7    | 8               |
| 125                         | 250.00 | 9.84  | 210.00 | 8.27  | 22.00 | 0.87 | 18.00 | 5/7    | 8               |
| 150                         | 285.00 | 11.22 | 240.00 | 9.45  | 22.00 | 0.87 | 22.00 | 7/8    | 8               |
| 200                         | 340.00 | 13.39 | 295.00 | 11.61 | 24.00 | 0.94 | 22.00 | 7/8    | 8               |
| 250                         | 395.00 | 15.55 | 350.00 | 13.78 | 26.00 | 1.02 | 22.00 | 7/8    | 12              |
| 300                         | 445.00 | 17.52 | 400.00 | 15.75 | 26.00 | 1.02 | 22.00 | 7/8    | 12              |
| 350                         | 505.00 | 19.88 | 460.00 | 18.11 | 26.00 | 1.02 | 22.00 | 7/8    | 16              |
| 400                         | 565.00 | 22.24 | 515.00 | 20.28 | 26.00 | 1.02 | 26.00 | 1 1/30 | 16              |
| 450                         | 615.00 | 24.21 | 565.00 | 22.24 | 28.00 | 1.10 | 26.00 | 1 1/30 | 20              |
| 500                         | 670.00 | 26.38 | 620.00 | 24.41 | 28.00 | 1.10 | 26.00 | 1 1/30 | 20              |
| 600                         | 780.00 | 30.71 | 725.00 | 28.54 | 30.00 | 1.18 | 30.00 | 1 1/2  | 20              |

## Flange dimensions

ANSI B16.5

DIN EN1092

### DIN EN1092 | DIN PN16

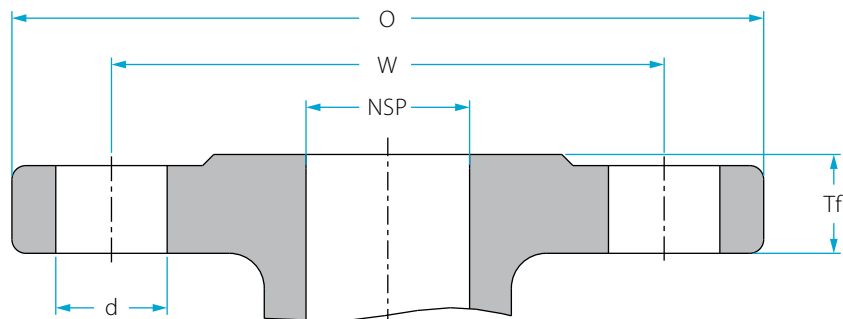

| NPS<br>Nominal<br>Pipe Size | O      |       | W      |       | Tf    |      | d     |      | Number<br>holes |
|-----------------------------|--------|-------|--------|-------|-------|------|-------|------|-----------------|
|                             | mm     | inch  | mm     | inch  | mm    | inch | mm    | inch |                 |
| 10                          | 90.00  | 3.54  | 60.00  | 2.36  | 16.00 | 0.63 | 14.00 | 0.55 | 4               |
| 15                          | 95.00  | 3.74  | 65.00  | 2.56  | 16.00 | 0.63 | 14.00 | 0.55 | 4               |
| 20                          | 105.00 | 4.13  | 75.00  | 2.95  | 18.00 | 0.71 | 14.00 | 0.55 | 4               |
| 25                          | 115.00 | 4.53  | 85.00  | 3.35  | 18.00 | 0.71 | 14.00 | 0.55 | 4               |
| 32                          | 140.00 | 5.51  | 100.00 | 3.94  | 18.00 | 0.71 | 18.00 | 0.71 | 4               |
| 40                          | 150.00 | 5.91  | 110.00 | 4.33  | 18.00 | 0.71 | 18.00 | 0.71 | 4               |
| 50                          | 165.00 | 6.50  | 125.00 | 4.92  | 18.00 | 0.71 | 18.00 | 0.71 | 4               |
| 65                          | 185.00 | 7.28  | 145.00 | 5.71  | 18.00 | 0.71 | 18.00 | 0.71 | 8               |
| 80                          | 200.00 | 7.87  | 160.00 | 6.30  | 20.00 | 0.79 | 18.00 | 0.71 | 8               |
| 100                         | 220.00 | 8.66  | 180.00 | 7.09  | 20.00 | 0.79 | 18.00 | 0.71 | 8               |
| 125                         | 250.00 | 9.84  | 210.00 | 8.27  | 22.00 | 0.87 | 18.00 | 0.87 | 8               |
| 150                         | 285.00 | 11.22 | 240.00 | 9.45  | 22.00 | 0.87 | 22.00 | 0.87 | 8               |
| 200                         | 340.00 | 13.39 | 295.00 | 11.61 | 24.00 | 0.94 | 26.00 | 1.02 | 12              |
| 250                         | 405.00 | 15.94 | 350.00 | 13.78 | 26.00 | 1.02 | 26.00 | 1.02 | 12              |
| 300                         | 460.00 | 18.11 | 400.00 | 15.75 | 28.00 | 1.10 | 26.00 | 1.02 | 12              |
| 350                         | 520.00 | 20.47 | 460.00 | 18.11 | 30.00 | 1.18 | 26.00 | 1.02 | 16              |
| 400                         | 580.00 | 22.83 | 515.00 | 20.28 | 32.00 | 1.26 | 30.00 | 1.3  | 16              |
| 450                         | 640.00 | 25.20 | 565.00 | 22.24 | 34.00 | 1.34 | 30.00 | 1.3  | 20              |
| 500                         | 715.00 | 28.15 | 620.00 | 24.41 | 36.00 | 1.42 | 33.00 | 1.3  | 20              |
| 600                         | 840.00 | 33.07 | 725.00 | 28.54 | 40.00 | 1.57 | 36.00 | 1.42 | 20              |

DIN EN1092 | DIN PN25

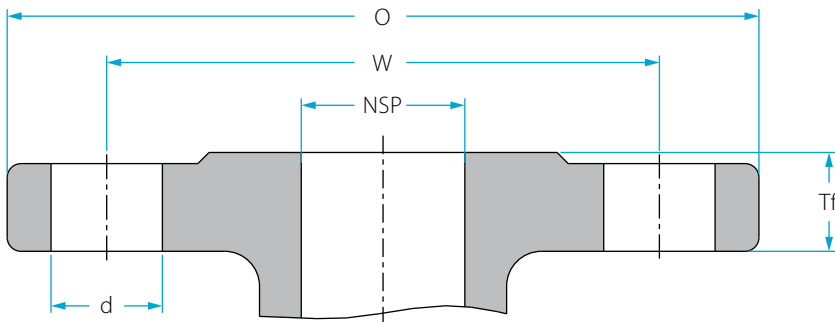

| NPS<br>Nominal<br>Pipe Size | O      |       | W      |       | Tf    |      | d     |      | Number<br>holes |
|-----------------------------|--------|-------|--------|-------|-------|------|-------|------|-----------------|
|                             | mm     | inch  | mm     | inch  | mm    | inch | mm    | inch |                 |
| 10                          | 90.00  | 3.54  | 60.00  | 2.36  | 16.00 | 0.63 | 14.00 | 0.55 | 4               |
| 15                          | 95.00  | 3.74  | 65.00  | 2.56  | 16.00 | 0.63 | 14.00 | 0.55 | 4               |
| 20                          | 105.00 | 4.13  | 75.00  | 2.95  | 18.00 | 0.71 | 14.00 | 0.55 | 4               |
| 25                          | 115.00 | 4.53  | 85.00  | 3.35  | 18.00 | 0.71 | 14.00 | 0.55 | 4               |
| 32                          | 140.00 | 5.51  | 100.00 | 3.94  | 18.00 | 0.71 | 18.00 | 0.71 | 4               |
| 40                          | 150.00 | 5.91  | 110.00 | 4.33  | 18.00 | 0.71 | 18.00 | 0.71 | 4               |
| 50                          | 165.00 | 6.50  | 125.00 | 4.92  | 20.00 | 0.79 | 18.00 | 0.71 | 4               |
| 65                          | 185.00 | 7.28  | 145.00 | 5.71  | 22.00 | 0.87 | 18.00 | 0.71 | 8               |
| 80                          | 200.00 | 7.87  | 160.00 | 6.30  | 24.00 | 0.94 | 18.00 | 0.71 | 8               |
| 100                         | 235.00 | 9.25  | 190.00 | 7.48  | 24.00 | 0.94 | 22.00 | 0.86 | 8               |
| 125                         | 270.00 | 10.63 | 220.00 | 8.66  | 26.00 | 1.02 | 26.00 | 1.02 | 8               |
| 150                         | 300.00 | 11.81 | 250.00 | 9.84  | 28.00 | 1.10 | 26.00 | 1.02 | 8               |
| 200                         | 360.00 | 14.17 | 310.00 | 12.20 | 30.00 | 1.18 | 26.00 | 1.02 | 12              |
| 250                         | 425.00 | 16.73 | 370.00 | 14.57 | 32.00 | 1.26 | 30.00 | 1.18 | 12              |
| 300                         | 485.00 | 19.09 | 430.00 | 16.93 | 34.00 | 1.34 | 30.00 | 1.18 | 16              |
| 350                         | 555.00 | 21.85 | 490.00 | 19.29 | 38.00 | 1.50 | 33.00 | 1.70 | 16              |
| 400                         | 620.00 | 24.41 | 550.00 | 21.65 | 40.00 | 1.57 | 36.00 | 1.42 | 16              |
| 450                         | 670.00 | 26.38 | 600.00 | 23.62 | 46.00 | 1.81 | 36.00 | 1.42 | 20              |
| 500                         | 730.00 | 28.74 | 660.00 | 25.98 | 48.00 | 1.89 | 36.00 | 1.42 | 20              |
| 600                         | 845.00 | 33.27 | 770.00 | 30.31 | 48.00 | 1.89 | 39.00 | 1.53 | 20              |

## Flange dimensions

ANSI B16.5

DIN EN1092

### DIN EN1092 | DIN PN40

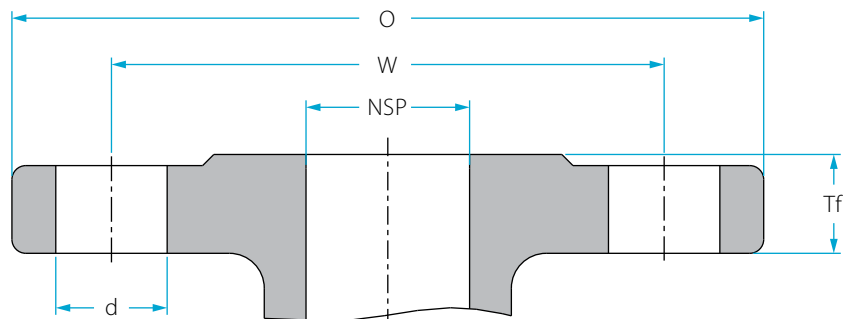

| NPS<br>Nominal<br>Pipe Size | O      |       | W      |       | Tf    |      | d     |      | Number<br>holes |
|-----------------------------|--------|-------|--------|-------|-------|------|-------|------|-----------------|
|                             | mm     | inch  | mm     | inch  | mm    | inch | mm    | inch |                 |
| 10                          | 90.00  | 3.54  | 60.00  | 2.36  | 16.00 | 0.63 | 140.0 | 0.55 | 4               |
| 15                          | 95.00  | 3.74  | 65.00  | 2.56  | 16.00 | 0.63 | 14.00 | 0.55 | 4               |
| 20                          | 105.00 | 4.13  | 75.00  | 2.95  | 18.00 | 0.71 | 14.00 | 0.55 | 4               |
| 25                          | 115.00 | 4.53  | 85.00  | 3.35  | 18.00 | 0.71 | 14.00 | 0.55 | 4               |
| 32                          | 140.00 | 5.51  | 100.00 | 3.94  | 18.00 | 0.71 | 18.00 | 0.71 | 4               |
| 40                          | 150.00 | 5.91  | 110.00 | 4.33  | 18.00 | 0.71 | 18.00 | 0.71 | 4               |
| 50                          | 165.00 | 6.50  | 125.00 | 4.92  | 20.00 | 0.79 | 18.00 | 0.71 | 4               |
| 65                          | 185.00 | 7.28  | 145.00 | 5.71  | 22.00 | 0.87 | 18.00 | 0.71 | 8               |
| 80                          | 200.00 | 7.87  | 160.00 | 6.30  | 24.00 | 0.94 | 18.00 | 0.71 | 8               |
| 100                         | 235.00 | 9.25  | 190.00 | 7.48  | 24.00 | 0.94 | 22.00 | 0.87 | 8               |
| 125                         | 270.00 | 10.63 | 220.00 | 8.66  | 26.00 | 1.02 | 26.00 | 1.02 | 8               |
| 150                         | 300.00 | 11.81 | 250.00 | 9.84  | 28.00 | 1.10 | 26.00 | 1.02 | 8               |
| 200                         | 375.00 | 14.76 | 320.00 | 12.60 | 34.00 | 1.34 | 30.00 | 1.18 | 12              |
| 250                         | 450.00 | 17.72 | 385.00 | 15.16 | 38.00 | 1.50 | 33.00 | 1.02 | 12              |
| 300                         | 515.00 | 20.28 | 450.00 | 17.72 | 42.00 | 1.65 | 33.00 | 1.3  | 16              |
| 350                         | 580.00 | 22.83 | 510.00 | 20.08 | 46.00 | 1.81 | 36.00 | 1.42 | 16              |
| 400                         | 660.00 | 25.98 | 585.00 | 23.03 | 50.00 | 1.97 | 39.00 | 1.53 | 16              |
| 450                         | 685.00 | 26.97 | 610.00 | 24.02 | 57.00 | 2.24 | 39.00 | 1.53 | 20              |
| 500                         | 755.00 | 29.72 | 670.00 | 26.38 | 57.00 | 2.24 | 42.00 | 1.65 | 20              |
| 600                         | 890.00 | 35.04 | 795.00 | 31.30 | 72.00 | 2.83 | 48.00 | 1.89 | 20              |

DIN EN1092 | DIN PN63

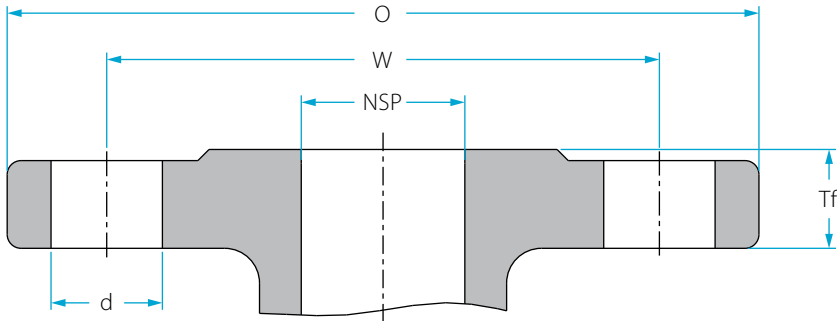

| NPS<br>Nominal<br>Pipe Size | O      |       | W      |       | Tf    |      | d     |      | Number<br>holes |
|-----------------------------|--------|-------|--------|-------|-------|------|-------|------|-----------------|
|                             | mm     | inch  | mm     | inch  | mm    | inch | mm    | inch |                 |
| 10                          | 100.00 | 3.94  | 70.00  | 2.76  | 20.00 | 0.79 | 14.00 | 0.55 | 4               |
| 15                          | 105.00 | 4.13  | 75.00  | 2.95  | 20.00 | 0.79 | 14.00 | 0.55 | 4               |
| 20                          | 130.00 | 5.12  | 90.00  | 3.54  | 22.00 | 0.87 | 18.00 | 0.71 | 4               |
| 25                          | 140.00 | 5.51  | 100.00 | 3.94  | 24.00 | 0.94 | 18.00 | 0.71 | 4               |
| 32                          | 155.00 | 6.10  | 110.00 | 4.33  | 24.00 | 0.94 | 22.00 | 0.87 | 4               |
| 40                          | 170.00 | 6.69  | 125.00 | 4.92  | 26.00 | 1.02 | 22.00 | 0.87 | 4               |
| 50                          | 180.00 | 7.09  | 135.00 | 5.31  | 26.00 | 1.02 | 22.00 | 0.87 | 4               |
| 65                          | 205.00 | 8.07  | 160.00 | 6.30  | 26.00 | 1.02 | 22.00 | 0.87 | 8               |
| 80                          | 215.00 | 8.46  | 170.00 | 6.69  | 28.00 | 1.10 | 22.00 | 0.87 | 8               |
| 100                         | 250.00 | 9.84  | 200.00 | 7.87  | 30.00 | 1.18 | 26.00 | 1.02 | 8               |
| 125                         | 295.00 | 11.61 | 240.00 | 9.45  | 34.00 | 1.34 | 30.00 | 1.18 | 8               |
| 150                         | 345.00 | 13.58 | 280.00 | 11.02 | 36.00 | 1.42 | 33.00 | 1.18 | 8               |
| 200                         | 415.00 | 16.34 | 345.00 | 13.58 | 42.00 | 1.65 | 36.00 | 1.42 | 12              |
| 250                         | 470.00 | 18.50 | 400.00 | 15.75 | 46.00 | 1.81 | 36.00 | 1.42 | 12              |
| 300                         | 530.00 | 20.87 | 460.00 | 18.11 | 52.00 | 2.05 | 36.00 | 1.42 | 16              |
| 350                         | 600.00 | 23.62 | 525.00 | 20.67 | 56.00 | 2.20 | 39.00 | 1.53 | 16              |
| 400                         | 670.00 | 26.38 | 585.00 | 23.03 | 60.00 | 2.36 | 42.00 | 1.65 | 16              |

## Flange dimensions

ANSI B16.5

DIN EN1092

### DIN EN1092 | DIN PN100

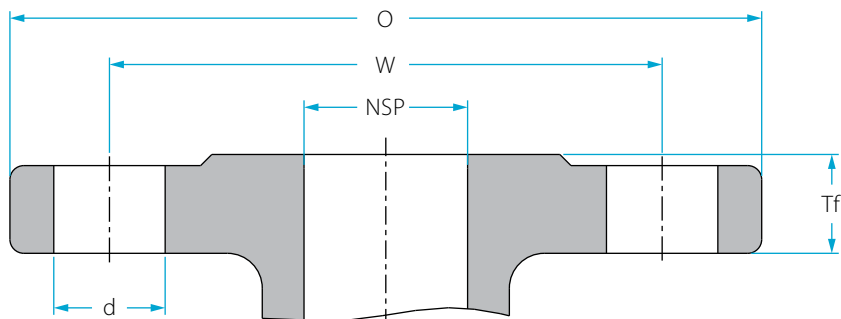

| NPS<br>Nominal<br>Pipe Size | O      |       | W      |       | Tf    |      | d     |      | Number<br>holes |
|-----------------------------|--------|-------|--------|-------|-------|------|-------|------|-----------------|
|                             | mm     | inch  | mm     | inch  | mm    | inch | mm    | inch |                 |
| 10                          | 100.00 | 3.94  | 70.00  | 2.76  | 20.00 | 0.79 | 14.00 | 0.55 | 4               |
| 15                          | 105.00 | 4.13  | 75.00  | 2.95  | 20.00 | 0.79 | 14.00 | 0.55 | 4               |
| 20                          | 130.00 | 5.12  | 90.00  | 3.54  | 22.00 | 0.87 | 18.00 | 0.71 | 4               |
| 25                          | 140.00 | 5.51  | 100.00 | 3.94  | 24.00 | 0.94 | 18.00 | 0.71 | 4               |
| 32                          | 155.00 | 6.10  | 110.00 | 4.33  | 24.00 | 0.94 | 22.00 | 0.87 | 4               |
| 40                          | 170.00 | 6.69  | 125.00 | 4.92  | 26.00 | 1.02 | 22.00 | 0.87 | 4               |
| 50                          | 195.00 | 7.68  | 145.00 | 5.71  | 28.00 | 1.10 | 26.00 | 1.02 | 4               |
| 65                          | 220.00 | 8.66  | 170.00 | 6.69  | 30.00 | 1.18 | 26.00 | 1.02 | 8               |
| 80                          | 230.00 | 9.06  | 180.00 | 7.09  | 32.00 | 1.26 | 26.00 | 1.02 | 8               |
| 100                         | 265.00 | 10.43 | 210.00 | 8.27  | 36.00 | 1.42 | 30.00 | 1.18 | 8               |
| 125                         | 315.00 | 12.40 | 250.00 | 9.84  | 40.00 | 1.57 | 33.00 | 1.3  | 8               |
| 150                         | 355.00 | 13.98 | 290.00 | 11.42 | 44.00 | 1.73 | 33.00 | 1.3  | 12              |
| 200                         | 430.00 | 16.93 | 360.00 | 14.17 | 52.00 | 2.05 | 36.00 | 1.42 | 12              |
| 250                         | 505.00 | 19.88 | 430.00 | 16.93 | 60.00 | 2.36 | 39.00 | 1.53 | 12              |
| 300                         | 585.00 | 23.03 | 500.00 | 19.69 | 68.00 | 2.68 | 42.00 | 1.65 | 16              |
| 350                         | 655.00 | 25.79 | 560.00 | 22.05 | 74.00 | 2.91 | 48.00 | 1.89 | 16              |

DIN EN1092 | DIN PN160

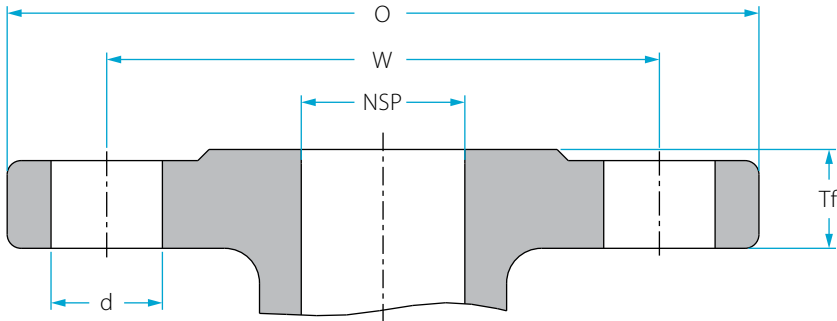

| NPS<br>Nominal<br>Pipe Size | O      |       | W      |       | Tf    |      | d     |      | Number<br>holes |
|-----------------------------|--------|-------|--------|-------|-------|------|-------|------|-----------------|
|                             | mm     | inch  | mm     | inch  | mm    | inch | mm    | inch |                 |
| 10                          | 100.00 | 3.94  | 70.00  | 2.76  | 20.00 | 0.79 | 14.00 | 0.55 | 4               |
| 15                          | 105.00 | 4.13  | 75.00  | 2.95  | 20.00 | 0.79 | 14.00 | 0.55 | 4               |
| 25                          | 140.00 | 5.51  | 100.00 | 3.94  | 24.00 | 0.94 | 18.00 | 0.71 | 4               |
| 40                          | 170.00 | 6.69  | 125.00 | 4.92  | 28.00 | 1.10 | 22.00 | 0.87 | 4               |
| 50                          | 195.00 | 7.68  | 145.00 | 5.71  | 30.00 | 1.18 | 26.00 | 1.02 | 4               |
| 65                          | 220.00 | 8.66  | 170.00 | 6.69  | 34.00 | 1.34 | 26.00 | 1.02 | 8               |
| 80                          | 230.00 | 9.06  | 180.00 | 7.09  | 36.00 | 1.42 | 26.00 | 1.02 | 8               |
| 100                         | 265.00 | 10.43 | 210.00 | 8.27  | 40.00 | 1.57 | 30.00 | 1.18 | 8               |
| 125                         | 315.00 | 12.40 | 250.00 | 9.84  | 44.00 | 1.73 | 33.00 | 1.3  | 8               |
| 150                         | 355.00 | 13.98 | 290.00 | 11.42 | 50.00 | 1.97 | 33.00 | 1.3  | 12              |
| 200                         | 430.00 | 16.93 | 360.00 | 14.17 | 60.00 | 2.36 | 36.00 | 1.42 | 12              |
| 250                         | 515.00 | 20.28 | 430.00 | 16.93 | 68.00 | 2.68 | 42.00 | 1.65 | 12              |
| 300                         | 585.00 | 23.03 | 500.00 | 19.69 | 78.00 | 3.07 | 42.00 | 1.65 | 16              |

## Flange dimensions

ANSI B16.5

DIN EN1092

### DIN EN1092 | DIN PN250

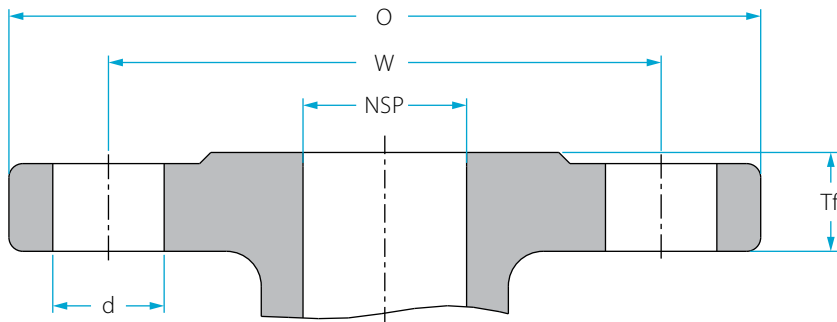

| NPS<br>Nominal<br>Pipe Size | O      |       | W      |       | Tf     |      | d     |      | Number<br>holes |
|-----------------------------|--------|-------|--------|-------|--------|------|-------|------|-----------------|
|                             | mm     | inch  | mm     | inch  | mm     | inch | mm    | inch |                 |
| 10                          | 125.00 | 4.92  | 85.00  | 3.35  | -      | -    | 18.00 | 0.71 | 4               |
| 15                          | 130.00 | 5.12  | 90.00  | 3.54  | 26.00  | 1.02 | 18.00 | 0.71 | 4               |
| 25                          | 150.00 | 5.91  | 105.00 | 4.13  | 28.00  | 1.10 | 22.00 | 0.87 | 4               |
| 40                          | 185.00 | 7.28  | 135.00 | 5.31  | 34.00  | 1.34 | 26.00 | 1.02 | 4               |
| 50                          | 200.00 | 7.87  | 150.00 | 5.91  | 38.00  | 1.50 | 26.00 | 1.02 | 8               |
| 65                          | 230.00 | 9.06  | 180.00 | 7.09  | 42.00  | 1.65 | 26.00 | 1.02 | 8               |
| 80                          | 255.00 | 10.04 | 200.00 | 7.87  | 46.00  | 1.81 | 30.00 | 1.18 | 8               |
| 100                         | 300.00 | 11.81 | 235.00 | 9.25  | 54.00  | 2.13 | 33.00 | 1.3  | 8               |
| 125                         | 340.00 | 13.39 | 275.00 | 10.83 | 60.00  | 2.36 | 33.00 | 1.3  | 12              |
| 150                         | 390.00 | 15.35 | 320.00 | 12.60 | 68.00  | 2.68 | 36.00 | 1.42 | 12              |
| 200                         | 485.00 | 19.09 | 400.00 | 15.75 | 82.00  | 3.23 | 42.00 | 1.65 | 12              |
| 250                         | 585.00 | 23.03 | 490.00 | 19.29 | 100.00 | 3.94 | 48.00 | 1.89 | 16              |
| 300                         | 690.00 | 27.17 | 590.00 | 23.23 | -      | -    | 52.00 | 2.05 | 16              |



DIN EN1092 | DIN PN320

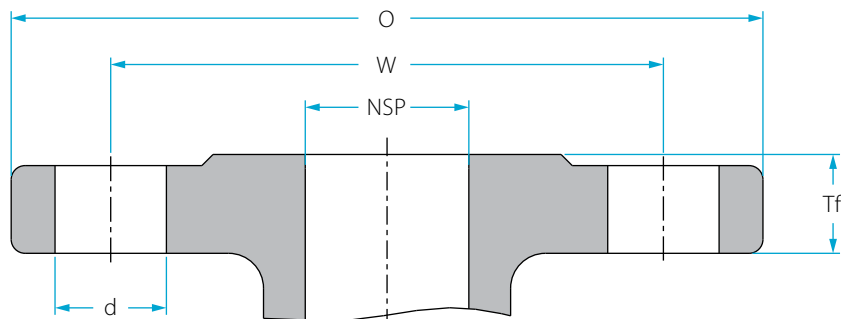

| NPS<br>Nominal<br>Pipe Size | O      |       | W      |       | Tf     |      | d     |                     | Number<br>holes |
|-----------------------------|--------|-------|--------|-------|--------|------|-------|---------------------|-----------------|
|                             | mm     | inch  | mm     | inch  | mm     | inch | mm    | inch                |                 |
| 10                          | 125.00 | 4.92  | 85.00  | 3.35  | 24.00  | 0.94 | 18.00 | 0.71                | 4               |
| 15                          | 130.00 | 5.12  | 90.00  | 3.54  | 26.00  | 1.02 | 18.00 | 0.71                | 4               |
| 25                          | 160.00 | 6.30  | 115.00 | 4.53  | 34.00  | 1.34 | 22.00 | 0.87                | 4               |
| 40                          | 195.00 | 7.68  | 145.00 | 5.71  | 38.00  | 1.50 | 26.00 | 1.02                | 4               |
| 50                          | 210.00 | 8.27  | 160.00 | 6.30  | 42.00  | 1.65 | 26.00 | 1.02                | 8               |
| 65                          | 255.00 | 10.04 | 200.00 | 7.87  | 51.00  | 2.01 | 30.00 | 1.18                | 8               |
| 80                          | 275.00 | 10.83 | 220.00 | 8.66  | 55.00  | 2.17 | 30.00 | 1.18 <sup>1/2</sup> | 8               |
| 100                         | 335.00 | 13.19 | 265.00 | 10.43 | 65.00  | 2.56 | 36.00 | 1.42                | 8               |
| 125                         | 380.00 | 14.96 | 310.00 | 12.20 | 75.00  | 2.95 | 36.00 | 1.42                | 12              |
| 150                         | 425.00 | 16.73 | 350.00 | 13.78 | 84.00  | 3.31 | 39.00 | 1.54                | 12              |
| 200                         | 525.00 | 20.67 | 440.00 | 17.32 | 103.00 | 4.06 | 42.00 | 1.65                | 16              |
| 250                         | 640.00 | 25.20 | 540.00 | 21.26 | 125.00 | 4.92 | 52.00 | 2.05                | 16              |

## Flange dimensions

ANSI B16.5

DIN EN1092

### DIN EN1092 | DIN PN400

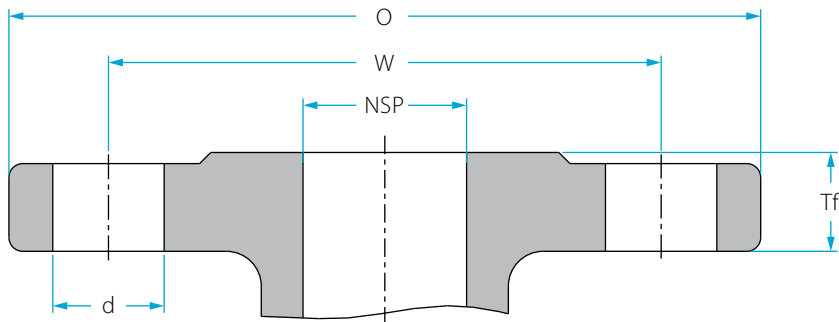

| NPS<br>Nominal<br>Pipe Size | O      |       | W      |       | Tf     |      | d     |      | Number<br>holes |
|-----------------------------|--------|-------|--------|-------|--------|------|-------|------|-----------------|
|                             | mm     | inch  | mm     | inch  | mm     | inch | mm    | inch |                 |
| 10                          | 125.00 | 4.92  | 85.00  | 3.35  | 28.00  | 1.10 | 18.00 | 0.71 | 4               |
| 15                          | 145.00 | 5.71  | 100.00 | 3.94  | 30.00  | 1.18 | 22.00 | 0.87 | 4               |
| 25                          | 180.00 | 7.09  | 130.00 | 5.12  | 38.00  | 1.50 | 26.00 | 1.02 | 4               |
| 40                          | 220.00 | 8.66  | 165.00 | 6.50  | 48.00  | 1.89 | 30.00 | 1.18 | 4               |
| 50                          | 235.00 | 9.25  | 180.00 | 7.09  | 52.00  | 2.05 | 30.00 | 1.18 | 8               |
| 65                          | 290.00 | 11.42 | 225.00 | 8.86  | 64.00  | 2.52 | 33.00 | 1.3  | 8               |
| 80                          | 305.00 | 12.01 | 240.00 | 9.45  | 68.00  | 2.68 | 33.00 | 1.3  | 8               |
| 100                         | 370.00 | 14.57 | 295.00 | 11.61 | 80.00  | 3.15 | 39.00 | 1.54 | 8               |
| 125                         | 415.00 | 16.34 | 340.00 | 13.39 | 92.00  | 3.62 | 39.00 | 1.54 | 12              |
| 150                         | 475.00 | 18.70 | 390.00 | 15.35 | 105.00 | 4.13 | 42.00 | 1.65 | 12              |
| 200                         | 585.00 | 23.03 | 490.00 | 19.29 | 130.00 | 5.12 | 48.00 | 1.89 | 16              |





www.habonim.com

**Habonim ISRAEL**

Tel: +972-4-6914911

Fax: +972-4-6914935

sales\_international@habonim.com

**Habonim EUROPE**

Tel: +34 640 384 759

sales\_eu@habonim.com

**Habonim UK**

Tel: +44-1633-484554

Fax: +44-1633-482252

sales\_uk@habonim.com

**Habonim USA**

Toll Free Phone: 1-866-261-8400

Toll Free Fax: 1-866-243-9959

sales\_usa@habonim.com

**Habonim CHINA**

Tel: + 86 21 64453190 \*146

sales\_china@habonim.com

**Habonim AUSTRALIA**

Tel: +61 3 9556 5428

sales\_au@habonimau.com



www.habonim.com

MAXMARK Technical Information-Flange dimensions 04/17 REV2.04

MAXMARK

