

## MATERIALS

Valve body: anodized aluminum (gold).  
Valve seals: body/plunger — NBR (nitrile).  
Mounting O-rings: NBR (nitrile) size 16X2 mm.  
Screws: (Impact to actuator) = Stainless steel.  
Exhaust: Delrin plug.  
The Impact includes O-ring interface seals and mounting screws.

## IMPORTANT NOTES:

The impact is not intended for use on actuators with positioners.

After the first operation air pressure will remain in the spring chambers. When removing the impact from the actuator, this residual air pressure will exhaust itself to the atmosphere.

The Impact increases the actuator speed of operation in the spring cycle and reduces the speed of operation in the air to open cycle. This is due to the fact that the air pressure which is trapped in the spring chambers is released during the open command.

## SAFETY & LIABILITY INFORMATION

### WARNING

Misuse or inappropriate application of any of these products may cause severe personal injury, and/or property damage. Consequences such as fire, explosion, toxic fumes, etc. may potentially result from improper use. Habonim makes ongoing efforts to assure that the information provided is accurate. Should you have any questions concerning specifications, please contact Habonim prior to purchase.



[www.habonim.com](http://www.habonim.com)

### Headquarters Habonim ISRAEL

Tel: +972 4 6914911  
Fax: +972 4 6914902  
[sales\\_international@habonim.com](mailto:sales_international@habonim.com)

### ISRAEL

Tel: 972 4 6914903  
Fax: +972-4-6914935  
[sales\\_israel@habonim.com](mailto:sales_israel@habonim.com)

### North America

Toll Free Phone: 1-866-261-8400  
Toll Free Fax: 1-866-243-9959  
[sales\\_usa@habonim.com](mailto:sales_usa@habonim.com)

### Europe

**Habonim Europe**  
Tel: +972 4 6914733  
Fax: +972 4 6914703  
[sales\\_europe@habonim.com](mailto:sales_europe@habonim.com)

### U.K.

**Habonim UK**  
Tel: 44-1633 484554  
Fax: 44-1633 482252  
[sales@habonimuk.com](mailto:sales@habonimuk.com)

### China

**Habonim China**  
Tel: 86-21-6445 3190\*146  
Fax: 86-21-6445 3191  
Mobile: 13918825940  
[www.habonim.com.cn](http://www.habonim.com.cn)

# IMPACT

## SPRING ASSIST

## Installation, Operation and Maintenance

### GENERAL

This Installation, Operating and Maintenance manual covers the instructions required for safe use of the Impact spring assist. Before using the Impact, read the entire IOM and make sure you understand everything.

Habonim cannot anticipate all of the situations a user may encounter while installing and using the Impact spring assist. The user must know and follow all applicable industry specifications on the safe installation and use of this product. Misapplication of the product may result in injuries or property damage. Refer to Habonim Impact spring assist catalogue for additional product safety information or contact Habonim.

1. Make sure the actuator is isolated from air supply or electrical ancillaries before attempting to do any maintenance.
2. Before removing the Impact spring assist from the actuator always make sure the air supply has been depressurized.
3. Utmost caution must be taken when handling the Impact spring assist and actuator. Only qualified personal are who are trained for maintenance work and have read the instructions are to assemble or disassemble the Impact spring assist.
4. Before operating an actuator which is connected to a valve in the pipeline make sure you know the valve function.
5. Do not leave any grip key or shaft connection attached to the actuator, or try to manually operate the actuator while it is still connected to the air pressure.
6. Use the Impact spring assist within the pressure and temperature limits indicated on the nameplate or as given in our catalogue.

### STORAGE

Keep the Impact in its protective packaging with the plastic plugs attached during storage. It is recommended to keep the Impact in a clean and dry environment until ready for use to guard against contamination, or damage to the threads.

### DESCRIPTION

The Impact is designed to operate with any Spring Return actuator. The Impact is fitted for direct mounting to Namur interface using mounting screws and location set screw.

Port A of the Impact is the inlet air supply. This port is connected to the center chamber of the spring return actuator and when pressurized will cause the springs to retract.

### INSTALLATION

Before installing the Impact, make sure all piping and fittings have been deburred, and the inside of the pipe cleaned of scale, rust and foreign material, pipe dope, teflon tape or other thread sealants.

### Actuator conforming to Namur interface

Thread the supplied M5 set screw into the hole of the actuator as shown below.

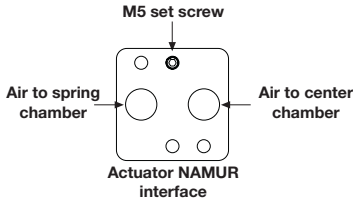

Make sure the two 16X2 O-rings are fitted in the Impact Namur grooves as shown below.

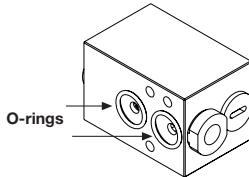

Connect the Impact to the actuator with the two mounting screws so that the M5 set screw head which you have screwed to the actuator protrudes into the blind hole on the Impact side as shown below.

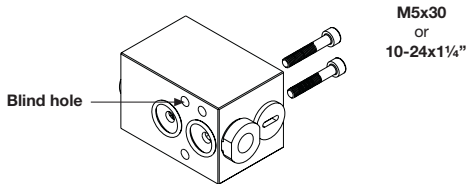

### Connecting solenoids to the Impact

When operating the actuator with a remote solenoid valve, connect the air supply from the solenoid to port A of the Impact.

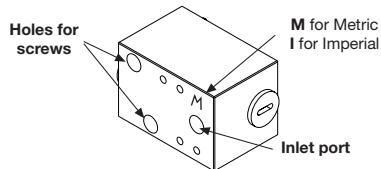

When operating the actuator with a direct mount 3/2 Namur solenoid valve, connect the solenoid to the Impact interface using two M5 screws for metric or 10-24 UNC for imperial (engraved M or I).

Make sure the 3/2 solenoid valve exhaust is 2.0 mm or larger.

**Do not** use flow control valves (flow restrictors) at the exhaust port of the solenoids.

### Actuator not conforming to Namur interface

Actuators which do not conform to Namur interface can be operated with the Impact with the special insert that converts it to a threaded connection for tube fittings.

Make sure the two 16X2 O-rings are fitted in the groove of the Namur holes.

Attach the insert to the Impact with the two M5 screws as shown below.

Connect the air supply to port A of the Impact.

Connect port A of the insert to the actuator air supply port.

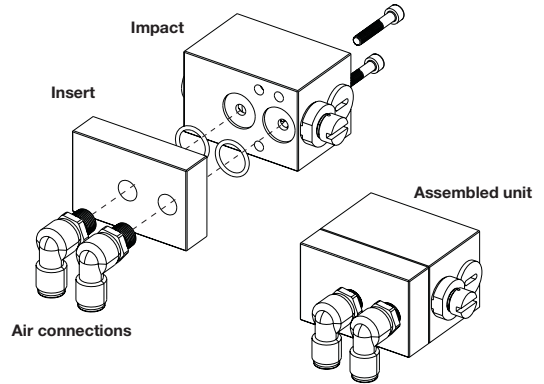

### LUBRICATION

The Impact comes lubricated from the factory and under normal operating conditions does not require re-lubrication. Do not try to remove or wash out the lubrication.

### FILTRATION

Dirt, dust and other abrasive materials can damage the polished, inside surfaces of the Impact. Use filtered air and furnish filters or mufflers on the exhaust ports. Air line filtration should be installed upstream of the lubricator and located as close as possible to the valve. Generally, a thirty (30) micron filter is adequate. Finer filters may be required, depending upon the operating conditions and environment.

### SPECIFICATION

**Pressure range:** 3-8 bar (45-120 psi)  
**Temperature range:** -20°C to +65°C (-4°F +150°F)  
**Connection:** Namur, or pipe connection  
**Physical Size:** 69 x 46 x 46 mm

### Namur Mounting

|                 |                                      |                                      |
|-----------------|--------------------------------------|--------------------------------------|
| Inlet port      | <b>Metric</b><br>G $\frac{3}{4}$ ISO | <b>Imperial</b><br>$\frac{1}{4}$ NPT |
| Mounting screws | M5 x 30                              | 10-24 x 1 $\frac{1}{4}$ " UNC        |
| Screw holes     | M5                                   | 10-24 UNC                            |